

Catalogue Book
ATEX 2019

Solutions for explosive atmospheres



excellence
FROM ITALY

Palazzoli

Palazzoli

Since 1904

In 1904 PALAZZOLI began its activity in Brescia when electrical energy was first used in the industry. The Company is specialized in manufacturing electrical appliances with safety features that are protected and watertight, for industrial, marine, civil, agricultural and OEM applications. The offer of PALAZZOLI extends into a wide range of finished products, to which special customized solutions are specifically developed in accordance to the needs of end-users. The products conform to technical and safety standards and are manufactured with very high quality materials, in metal and self-extinguishing isolated thermosetting (GRP) and thermoplastic. PALAZZOLI undertakes the commitment towards all end-users to offer reliable, safe and lasting quality products. This task, as in the last century of activity, continues to honour the trust and respect that customers have posted in its trademark.



RESISTANCE, LONG LIFE AND RELIABILITY FOR
SUSTAINABLE PRODUCT DEVELOPMENT AND
APPLICATION

LEADING EXPERIENCE
AND KNOW-HOW IN
ELECTROTECHNOLOGY

HIGH QUALITY
PERFORMANCE OF
TECHNICAL SOLUTIONS



MADE IN PALAZZOLI

Palazzoli obtained from IMQ the certificate

IMQ 07 ATEXQ 001

guaranteeing that its ATEX equipments
can be used in hazardous areas for the
presence of gases, vapours, mists or dusts.

Tested Quality

Palazzoli ATEX equipments are designed and manufactured in order to avoid the risk of ignition.

Each equipment is approved and certified by a notified body in compliance with the Directive 2014/34/EU which guarantees the conformity for installation in hazardous areas. Each ATEX enclosure is tested as follows in compliance with EN 60079-0 standards:

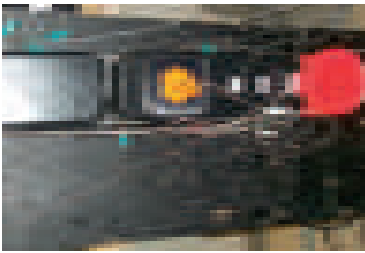

- 1) Operating temperature
in order to determine the maximum operating temperature of the equipment.



- 2) Temperature Endurance Test
in climatic room at the maximum service temperature measured with the previous test with 90% humidity for 4 weeks, and at the minimum temperature $-25^{\circ}\text{C} \div -30^{\circ}\text{C}$ for one day.



- 3) Impact test
tested at $+10^{\circ}\text{C} \div 15^{\circ}\text{C}$ and $-5^{\circ}\text{C} \div 10^{\circ}\text{C}$ of the maximum operating temperature.



- 4) IPXX protection rating test
(dust and water).



- 5) Tests on specific methods of protection
(pressure test, restricted breathing test, dielectric tests).

The technical characteristics of the equipments included in this catalogue are defined after the sequence of the above reported tests, in the indicated order and on the same sample piece.

PLUGS AND INTERLOCKED SOCKETS



INDUSTRIAL PLUGS IN ANTISTATIC MATERIAL	6
---	---



INTERLOCKED SOCKETS	
IN ANTISTATIC THERMOSETTING (GRP)	8
IN ALUMINIUM ALLOY	14

BOXES AND CABLE GLANDS



BOXES	
IN ANTISTATIC THERMOSETTING (GRP)	18
IN ALUMINIUM ALLOY	20



CABLE GLANDS	
CABLE GLANDS AND ADAPTORS	24
CABLE GLANDS FOR ARMoured CABLES	27

CONTROL AND SIGNALLING DEVICES



ROTARY CONTROL DEVICES	
IN ANTISTATIC THERMOSETTING (GRP)	28
IN ALUMINIUM ALLOY	30



SMALL CONTROL DEVICES	
IN ANTISTATIC THERMOSETTING (GRP)	32
IN ALUMINIUM ALLOY	34

SMALL CONTROL DEVICES



SIRENS AND BELLS

36

LIGHTING DEVICES



LIGHTING FIXTURES IN STAINLESS STEEL

38



OVAL AND ROUND BULKHEAD LAMPS
IN ALUMINIUM ALLOY

42



LED LIGHTING FIXTURES IN STAINLESS STEEL

44

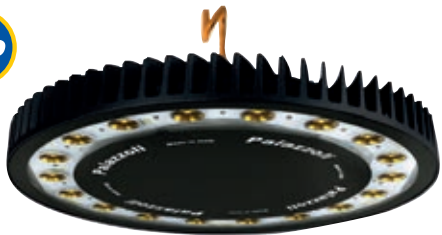

HIGH-BAY LIGHTING FIXTURES AND FLOODLIGHTS

46

PALAZZOLI ACADEMY

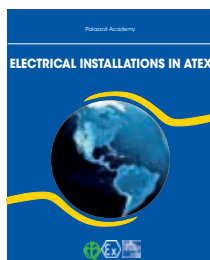

ELECTRICAL INSTALLATIONS IN ATEX

53

X-CEE-EX Series

Zones 2, 21, 22

INDUSTRIAL PLUGS IN ANTISTATIC MATERIAL



	GAS			DUST		
ZONE	0	1	2	20	21	22
USABLE			X		X	X

Low-voltage straight mobile plugs, standard type EN 60309-1 and EN 60309-2, suitable for use in explosion hazardous areas, as defined by the ATEX Directive 2014/34/EU.

The quality of the materials, the terminals with cage clamps throughout the range, the broad entry cable clamping, the total protection rating, the resistance to impacts and crushing make this range suitable for use in the harshest environments.

The range offers maximum ease of use, with details such as easy cable coupling, the possibility of use in suspension, the absence of screws to fix the grips and ergonomic shapes.

Cable features:

Rated current (A)	Poles	Entry cable diameters (mm)	Cable cross-section (mm ²)
16	2P+≡	6,3 ÷ 18	1 ÷ 10
	3P+≡		
	3P+N+≡	9 ÷ 23	
32	2P+≡	9 ÷ 23	1 ÷ 10
	3P+≡		
	3P+N+≡	13 ÷ 27	
63	2P+≡	14 ÷ 36	6 ÷ 25
	3P+≡		
	3P+N+≡		

Compliance with standards
Directive ATEX 2014/34/EU
EN 60079-0
EN 60079-15
EN 60079-31
Directive LVD 2014/35/EU
EN 60309-1
EN 60309-2

ATEX execution
 **II 3G 3D**
Ex nA IIC T6 Gc
Ex tb IIIC T 90°C Db

Casing material
High-thickness antistatic technopolymer

Surface resistance
<109 Ω
(prevention of electrostatic charge accumulation)

Protection rating (IP according to IEC/EN 60529)
IP66/IP67

Colour
RAL 9005 (black)

Rated current
16A - 32A - 63A

Operating voltage
110V - 500V

Operating frequency
50-60Hz

Insulation voltage
500V

Operating temperature
-40°C ÷ +60°C



Technical data sheets updated to new standards on palazzoli.com website

SUITABLE FOR ZONES 2 (GAS) AND 21, 22 (DUST)



High-performance
straight mobile plugs
50-60Hz
IP66/IP67

Rated current (A)	Rated voltage (V)	Voltage colour	Poles	h ref.	Palazzoli code	Pack Qty
16	110	●	2P+⚡	4	760124EX	1
	110	●	3P+⚡	4	760134EX	1
	110	●	3P+N+⚡	4	760144EX	1
	230	●	2P+⚡	6	760126EX	1
	230	●	3P+⚡	9	760139EX	1
	230	●	3P+N+⚡	9	760149EX	1
	400	●	2P+⚡	9	760129EX	1
	400	●	3P+⚡	6	760136EX	1
	400	●	3P+N+⚡	6	760146EX	1
	500	●	3P+⚡	7	760137EX	1
32	110	●	2P+⚡	4	760224EX	1
	110	●	3P+⚡	4	760234EX	1
	110	●	3P+N+⚡	4	760244EX	1
	230	●	2P+⚡	6	760226EX	1
	230	●	3P+⚡	9	760239EX	1
	230	●	3P+N+⚡	9	760249EX	1
	400	●	2P+⚡	9	760229EX	1
	400	●	3P+⚡	6	760236EX	1
	400	●	3P+N+⚡	6	760246EX	1
	500	●	3P+⚡	7	760237EX	1
63	110	●	2P+⚡	4	760324EX	1
	110	●	3P+⚡	4	760334EX	1
	110	●	3P+N+⚡	4	760344EX	1
	230	●	2P+⚡	6	760326EX	1
	230	●	3P+⚡	9	760339EX	1
	230	●	3P+N+⚡	9	760349EX	1
	400	●	2P+⚡	9	760329EX	1
	400	●	3P+⚡	6	760336EX	1
	400	●	3P+N+⚡	6	760346EX	1
	500	●	3P+⚡	7	760337EX	1
500	●	3P+N+⚡	7	760347EX	1	



Watertight caps
for plugs
IP66/IP67

Rated current (A)	Poles	Palazzoli code	Pack Qty
16	2P+⚡	476903EX	1
	3P+⚡	476913EX	1
	3P+N+⚡	476923EX	1
32	2P+⚡ / 3P+⚡	476905EX	1
	3P+N+⚡	476925EX	1
63	2P+⚡ / 3P+⚡ / 3P+N+⚡	476907EX	1
125	2P+⚡ / 3P+⚡ / 3P+N+⚡	476909EX	1

Features: ensures the IP67 protection rating when the plug is not in use.

TAIS-EX Series

Zones 2, 21, 22

INTERLOCKED SOCKETS
IN ANTISTATIC THERMOSETTING (GRP)



ZONE	GAS			DUST		
	0	1	2	20	21	22
USABLE			X		X	X

Watertight wall-mounted interlocked socket-outlets with housing in Palazzoli antistatic thermosetting GRP for use in explosion hazardous areas, as defined in the ATEX Directive 2014/34/EU. The cover is attached to the body by means of stainless steel screws, while the sealing is ensured by a reinforced gasket in non-ageing elastomer which ensures an IP66 protection rating. The interlock mechanism is made of metal, and the operation handle is category AC23A-AC3 at rated current with conditional short-circuit current ≥ 10 kA.

Rated operating current:

		16A	20A 32A	40A 63A	
Thermal current Ith	A	16	32	63	
AC21A	A	16	32	63	
AC22A	A	16	32	63	
AC23A	A	16	32	63	
AC23A	230V	kW	4,5	8,5	20
	400V		7,5	15	34
	500V		8,5	17	44
AC3	230V	kW	4,5	8,5	18
	400V		7,5	15	31
	500V		8,5	17	40

Wiring data:

		16A	20A 32A	40A 63A
Entry cable diameters	mm	12 - 18	16 - 25	22 - 32
Entry cable sections	mm ²	1 - 10		6 - 16
Tightening torque	Nm	2		

Compliance with standards
Directive ATEX 2014/34/EU
EN 60079-0
EN 60079-15
EN 60079-31

Directive LVD 2014/35/EU
EN 60309-1
EN 60309-2
EN 60309-4

Ex II 3G 2D

ATEX execution
(sockets)
x nR IIC T5/T6 Gc
Ex tb IIIC T 80°C...140 °C Db
(table on page 9)

(boxes)
Ex nR IIC Gc
Ex tb IIIC Db

Casing material
Palazzoli antistatic thermosetting GRP

Surface resistance
<10⁹ Ω
(prevention of electrostatic charge accumulation)

Protection rating (IP according to IEC/EN 60529)
IP66

Colour
RAL 9005 (black)

Resistance to abnormal heat and fire ("Glow wire" according to IEC/EN 60695-2-10)
960°C

Flammability rating (according to UL94)
V0

Rated current
16A - 32A - 63A

Operating Voltage
110V - 500V

Operating frequency
50 - 60Hz

Conditional short-circuit current - isolator switch
 ≥ 10 kA

Insulation voltage
500V

Insulation class
II

Operating temperature
-40°C ÷ +65°C
-40°C ÷ +40°C sockets with fuse-holder and with MCB
(table on page 9)



Technical data sheets updated to new standards on palazzoli.com website



TABLE OF AMBIENT TEMPERATURES AND ATEX MARKINGS

Version	In	Ambient temperature	Temperature class	Maximum surface temperature	Cable temperature
DUST					
Direct	16A	-40°C ÷ +50°C		T90°C	-
		-40°C ÷ +65°C		T105°C	95°C
	32A	-40°C ÷ +50°C		T110°C	-
		-40°C ÷ +65°C		T125°C	95°C
	63A	-40°C ÷ +50°C		T125°C	-
		-40°C ÷ +65°C		T140°C	95°C
Fuse	16A		T80°C	-	
	32A		T100°C		
	63A		T115°C		105°C
MCB	16A	-40°C ÷ +40°C	T80°C	-	
	32A		T100°C		
	63A		T115°C		105°C
GAS					
Direct	16A	-40°C ÷ +50°C	T6		-
		-40°C ÷ +65°C	T5		95°C
	32A	-40°C ÷ +50°C	T6		-
		-40°C ÷ +65°C	T5		95°C
	63A	-40°C ÷ +50°C	T6		-
		-40°C ÷ +65°C	T5		95°C
Fuse	16A		T6	-	
	20A				
	40A				
MCB	16A	-40°C ÷ +40°C	T6	-	
	32A				
	40A				

TABLE OF THE MAXIMUM DISSIPATED POWER OF THE BOXES FOR SETS OF SOCKETS

Palazzoli code	-40 ÷ +40°C (W)	-40 ÷ +50°C (W)	-40 ÷ +65°C (W)
DUST			
532240EX	18	12	6
532242EX	23	22	11
532244EX	25	25	23
GAS			
532240EX	8	8	6
532242EX	8	7	7
532244EX	9	8	8

Boxes on page 12

TABLE FOR THE SELECTION OF PLUGS THAT CAN BE COMBINED WITH THE SOCKETS FOR ZONE 2

Rated current			
Socket-outlet with fuses	Socket-outlet with MCB	Socket-outlet without protection	Plug
16A	16A	16A	16A
20A	32A	32A	32A
40A	40A	63A	63A

SUITABLE FOR ZONES 21-22 (DUST)

MODULE 125



Modular interlocked socket-outlets in thermosetting GRP for wall-mounting 50-60Hz **IP66**

Rated current (A)	Rated voltage (V)	Voltage colour	Poles	h. ref.	Palazzoli code	Pack Qty	
16	110	Yellow	2P+⊕	4	467124EX	1	
	M25 entry	110	Yellow	3P+⊕	4	467134EX	1
		110	Yellow	3P+N+⊕	4	467144EX	1
	230	Blue	2P+⊕	6	467126EX	1	
	230	Blue	3P+⊕	9	467139EX	1	
	230	Blue	3P+N+⊕	9	467149EX	1	
	400	Red	2P+⊕	9	467129EX	1	
	400	Red	3P+⊕	6	467136EX	1	
	400	Red	3P+N+⊕	6	467146EX	1	
	500	Black	3P+⊕	7	467137EX	1	
	500	Black	3P+N+⊕	7	467147EX	1	
	32	110	Yellow	2P+⊕	4	470224EX	1
M32 entry		110	Yellow	3P+⊕	4	470234EX	1
		110	Yellow	3P+N+⊕	4	470244EX	1
230		Blue	2P+⊕	6	470226EX	1	
230		Blue	3P+⊕	9	470239EX	1	
230		Blue	3P+N+⊕	9	470249EX	1	
400		Red	2P+⊕	9	470229EX	1	
400		Red	3P+⊕	6	470236EX	1	
400		Red	3P+N+⊕	6	470246EX	1	
500		Black	3P+⊕	7	470237EX	1	
500		Black	3P+N+⊕	7	470247EX	1	
63		110	Yellow	2P+⊕	4	470324EX	1
	M40 entry	110	Yellow	3P+⊕	4	470334EX	1
		110	Yellow	3P+N+⊕	4	470344EX	1
	230	Blue	2P+⊕	6	470326EX	1	
	230	Blue	3P+⊕	9	470339EX	1	
	230	Blue	3P+N+⊕	9	470349EX	1	
	400	Red	2P+⊕	9	470329EX	1	
	400	Red	3P+⊕	6	470336EX	1	
	400	Red	3P+N+⊕	6	470346EX	1	
	500	Black	3P+⊕	7	470337EX	1	
	500	Black	3P+N+⊕	7	470347EX	1	

Equipment included: cable gland in technopolymer.

Technical accessories: enclosures for compositions at page 12. Thermosetting (GRP) backplate at page 12.

SUITABLE FOR ZONES 21-22 (DUST)

MODULE 125



Modular interlocked socket-outlets in thermosetting GRP with **fuse holder base** for wall-mounting 50-60Hz **IP66**

Rated current (A)	Rated voltage (V)	Voltage colour	Poles	h. ref.	Palazzoli code	Pack Qty
16 entry M25 fuses 10,3x38	110	Yellow	2P+⊕	4	463124EX	1
	110	Yellow	3P+⊕	4	463134EX	1
	110	Yellow	3P+N+⊕	4	463144EX	1
	230	Blue	2P+⊕	6	463126EX	1
	230	Blue	3P+⊕	9	463139EX	1
	230	Blue	3P+N+⊕	9	463149EX	1
	400	Red	2P+⊕	9	463129EX	1
	400	Red	3P+⊕	6	463136EX	1
	400	Red	3P+N+⊕	6	463146EX	1
	500	Black	3P+⊕	7	463137EX	1
32 entry M32 fuses 14x51	110	Yellow	2P+⊕	4	472611EX	1
	110	Yellow	3P+⊕	4	472711EX	1
	110	Yellow	3P+N+⊕	4	472811EX	1
	230	Blue	2P+⊕	6	472621EX	1
	230	Blue	3P+⊕	9	472721EX	1
	230	Blue	3P+N+⊕	9	472821EX	1
	400	Red	2P+⊕	9	472631EX	1
	400	Red	3P+⊕	6	472731EX	1
	400	Red	3P+N+⊕	6	472831EX	1
	500	Black	3P+⊕	7	472751EX	1
63 entry M40 fuses E33 DIII	110	Yellow	2P+⊕	4	472612EX	1
	110	Yellow	3P+⊕	4	472712EX	1
	110	Yellow	3P+N+⊕	4	472812EX	1
	230	Blue	2P+⊕	6	472622EX	1
	230	Blue	3P+⊕	9	472722EX	1
	230	Blue	3P+N+⊕	9	472822EX	1
	400	Red	2P+⊕	9	472632EX	1
	400	Red	3P+⊕	6	472732EX	1
	400	Red	3P+N+⊕	6	472832EX	1
	500	Black	3P+⊕	7	472752EX	1
500	Black	3P+N+⊕	7	472842EX	1	

Equipment included: cable gland in technopolymer.

Features: fuses not included. Codes 472612EX, 472622EX, 472632EX have a cable gland with entry diameter of 16-26 mm.

Technical accessories: enclosures for compositions at page 12. Thermosetting (GRP) backplate at page 12.

SOFTWARE FOR DESIGNING AND INSTALLING SOCKET BOARDS

MODULE 125



Modular interlocked socket-outlets in thermosetting GRP with **MCB** for wall-mounting 50-60Hz **IP66**

Rated current (A)	Rated voltage (V)	Voltage colour	Poles	h. ref.	Palazzoli code	Pack Qty	
16 entry M25 MCB 4,5 kA curve C	110	Yellow	2P+⊕	4	464210EX	1	
	110	Yellow	3P+⊕	4	464310EX	1	
	110	Yellow	3P+N+⊕	4	464410EX	1	
	230	Blue	2P+⊕	6	464220EX	1	
	230	Blue	3P+⊕	9	464320EX	1	
	230	Blue	3P+N+⊕	9	464420EX	1	
	400	Red	2P+⊕	9	464230EX	1	
	400	Red	3P+⊕	6	464330EX	1	
	400	Red	3P+N+⊕	6	464430EX	1	
	32 entry M32 MCB 6kA curve C	110	Yellow	3P+⊕	4	464711EX	1
110		Yellow	3P+N+⊕	4	464811EX	1	
230		Blue	2P+⊕	6	464621EX	1	
230		Blue	3P+⊕	9	464721EX	1	
400		Red	3P+⊕	6	464731EX	1	
400		Red	3P+N+⊕	6	464831EX	1	
63 entry M40 MCB 10kA curve C		230	Blue	3P+⊕	9	464722EX	1
		400	Red	3P+⊕	6	464732EX	1
		400	Red	3P+N+⊕	6	464832EX	1

Equipment included: cable gland in technopolymer.

Features: voltage presence indicator light.

Code 464722EX has a cable gland with an entry diameter of 16-26 mm.

Technical accessories: enclosures for compositions at page 12.

Thermosetting (GRP) backplate at page 12.

Software for the design and cost estimation of distribution boards

For any application need you can create your own distribution boards online with TAIS-EX sockets for use in explosion hazardous areas

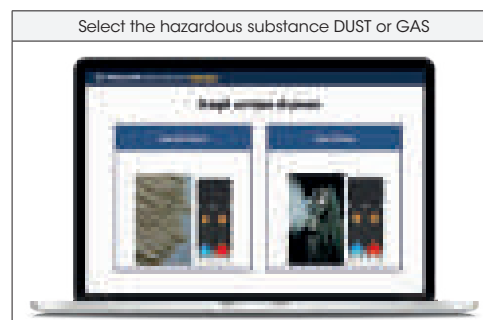

The Tais-EX software is active on www.palazzoli.com



SUITABLE FOR ZONE 2 (GAS)

MODULE 125



Modular interlocked socket-outlets in thermosetting GRP for wall-mounting 50-60Hz **IP66**

Rated current (A)	Rated voltage (V)	Voltage colour	Poles	h. ref.	Palazzoli code	Pack Qty
16 entry M25	110	●	2P+⊕	4	467124EX	1
	110	●	3P+⊕	4	467134EX	1
	110	●	3P+N+⊕	4	467144EX	1
	230	●	2P+⊕	6	467126EX	1
	230	●	3P+⊕	9	467139EX	1
	230	●	3P+N+⊕	9	467149EX	1
	400	●	2P+⊕	9	467129EX	1
	400	●	3P+⊕	6	467136EX	1
	400	●	3P+N+⊕	6	467146EX	1
	500	●	3P+⊕	7	467137EX	1
32 entry M32	110	●	2P+⊕	4	470224EX	1
	110	●	3P+⊕	4	470234EX	1
	110	●	3P+N+⊕	4	470244EX	1
	230	●	2P+⊕	6	470226EX	1
	230	●	3P+⊕	9	470239EX	1
	230	●	3P+N+⊕	9	470249EX	1
	400	●	2P+⊕	9	470229EX	1
	400	●	3P+⊕	6	470236EX	1
	400	●	3P+N+⊕	6	470246EX	1
	500	●	3P+⊕	7	470237EX	1
63 entry M40	110	●	2P+⊕	4	470324EX	1
	110	●	3P+⊕	4	470334EX	1
	110	●	3P+N+⊕	4	470344EX	1
	230	●	2P+⊕	6	470326EX	1
	230	●	3P+⊕	9	470339EX	1
	230	●	3P+N+⊕	9	470349EX	1
	400	●	2P+⊕	9	470329EX	1
	400	●	3P+⊕	6	470336EX	1
	400	●	3P+N+⊕	6	470346EX	1
	500	●	3P+⊕	7	470337EX	1
500	●	3P+N+⊕	7	470347EX	1	

Equipment included: cable gland in technopolymer.
Notes: the 63A socket-outlets installed side by side in combination can be used only up to 50A.
Technical accessories: enclosures for compositions at page 12. Thermosetting (GRP) backplate at page 12.

MODULE 125

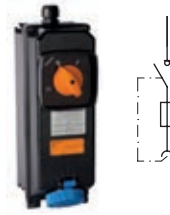

Modular interlocked socket-outlets in thermosetting GRP with **fuse holder base** for wall-mounting 50-60Hz **IP66**

Rated current (A)	Rated voltage (V)	Voltage colour	Poles	h. ref.	Palazzoli code	Pack Qty
16 entry M25 fuses 10,3x38	110	●	2P+⊕	4	463124EX	1
	110	●	3P+⊕	4	463134EX	1
	110	●	3P+N+⊕	4	463144EX	1
	230	●	2P+⊕	6	463126EX	1
	230	●	3P+⊕	9	463139EX	1
	230	●	3P+N+⊕	9	463149EX	1
	400	●	2P+⊕	9	463129EX	1
	400	●	3P+⊕	6	463136EX	1
	400	●	3P+N+⊕	6	463146EX	1
	500	●	3P+⊕	7	463137EX	1
20 entry M32 fuses 14x51	110	●	2P+⊕	4	472611EX	1
	110	●	3P+⊕	4	472711EX	1
	110	●	3P+N+⊕	4	472811EX	1
	230	●	2P+⊕	6	472621EX	1
	230	●	3P+⊕	9	472721EX	1
	230	●	3P+N+⊕	9	472821EX	1
	400	●	2P+⊕	9	472631EX	1
	400	●	3P+⊕	6	472731EX	1
	400	●	3P+N+⊕	6	472831EX	1
	500	●	3P+⊕	7	472751EX	1
40 entry M32 fuses 14x51	110	●	2P+⊕	4	463324EX	1
	110	●	3P+⊕	4	463334EX	1
	110	●	3P+N+⊕	4	463344EX	1
	230	●	2P+⊕	6	463326EX	1
	230	●	3P+⊕	9	463339EX	1
	230	●	3P+N+⊕	9	463349EX	1
	400	●	2P+⊕	9	463329EX	1
	400	●	3P+⊕	6	463336EX	1
	400	●	3P+N+⊕	6	463346EX	1
	500	●	3P+⊕	7	463337EX	1
500	●	3P+N+⊕	7	463347EX	1	

Equipment included: cable gland in technopolymer.
Features: fuses not included.
Technical accessories: enclosures for compositions at page 12. Thermosetting (GRP) backplate at page 12.

SUITABLE FOR ZONE 2 (GAS)

MODULE 125



Modular interlocked socket-outlets in thermosetting GRP with **MCB** for wall-mounting **50-60Hz IP66**

Rated current (A)	Rated voltage (V)	Voltage colour	Poles	h ref.	Palazzoli code	Pack Qty
16	110	Yellow	2P+⊕	4	464210EX	1
entry M25	110	Yellow	3P+⊕	4	464310EX	1
	110	Yellow	3P+N+⊕	4	464410EX	1
MCB 4,5 kA curve C	230	Blue	2P+⊕	6	464220EX	1
	230	Blue	3P+⊕	9	464320EX	1
	230	Blue	3P+N+⊕	9	464420EX	1
	400	Red	2P+⊕	9	464230EX	1
	400	Red	3P+⊕	6	464330EX	1
32	110	Yellow	3P+⊕	4	464711EX	1
	110	Yellow	3P+N+⊕	4	464811EX	1
entry M32	230	Blue	2P+⊕	6	464621EX	1
MCB 6 kA curve C	230	Blue	3P+⊕	9	464721EX	1
	400	Red	3P+⊕	6	464731EX	1
	400	Red	3P+N+⊕	6	464831EX	1
40 entry M32 MCB 10kA curve C	230	Blue	3P+⊕	9	464339EX	1
	400	Red	3P+⊕	6	464336EX	1
	400	Red	3P+N+⊕	6	464346EX	1

Equipment included: insulated cable gland.
Characteristics: lamp indicating presence of voltage.



Device for testing the restricted breathing of the sockets

Corrente nominale prese	Numero poli	Palazzoli code	Pack Qty
16A	2P+⊕	478126	1
	3P+⊕	478136	1
	3P+N+⊕	478146	1
20A/32A	2P+⊕/3P+⊕	478206	1
	3P+N+⊕	478246	1
40A/63A	2P+⊕/3P+⊕/3P+N+⊕	478306	1

Equipment included: transparent tube to be applied to the testing device.
Instructions: insert the testing device into the socket-outlet (test port), tighten the device's ring nut and do the testing according to Art. 33.7.1 of EN60079-15 standards with the suitable measuring device.

SUITABLE FOR ZONES 2 (GAS) AND 21-22 (DUST)



Boxes in thermosetting GRP with blind cover for the creation of multiple socket boards **IP66**

Outer dimensions (mm)	Power dissipation Ta = +40°C*		No. of installable devices	Palazzoli code	Pack Qty
	Gas	Dust			
125x185x125	8	18	1	532240EX	1
250x185x125	8	23	2	532242EX	1
380x185x125	9	25	3	532244EX	1

Features: supplied with drilling template. The protection rating and the consequent certification of the distribution board are guaranteed if the holes in the boxes are made with the special set of hole cutters of the TAIS series, code 538410 according to the instructions provided with the product.

*For Ta values >40°C see the table on page 301.



Mounting plates in thermosetting GRP with guided system for the creation of multiple socket boards

Outer dimensions (mm)	No. of installable devices	Palazzoli code	Pack Qty
125x630	1	538800	1
250x630	2	538802	1
380x630	3	538804	1

Equipment included: pre-arranged with brass grub screws and stainless steel screws for fastening devices.

Features: the guided positioning system simplifies the assembly of the devices onto the plate.



Fittings for coupling sockets with boxes **IP66**

From hole	To hole	Thread length (mm)	Palazzoli code	Pack Qty
M25	M25	23	538421EX	1
M32	M32	23	538429EX	1
M40	M40	23	538436EX	1

Features: they are required to couple sockets with boxes.



Set of hole cutters cup shaped in steel for quick drill connection tungsten carbide teeth specific for thermosetting GRP

Hole type	Diameter (mm)	Palazzoli code	Pack Qty
M20 - M25 - M32 - M40	20,5 - 25,5 - 32,5 - 40,5	538410	1



GUIDE TO THE CREATION OF COMPOSITIONS WITH TAIS-EX SOCKETS

ATEX
II 2D Ex tb IIIC
T 80°...140°C
Db

II 3G Ex nR IIC
T5/T6 Gc

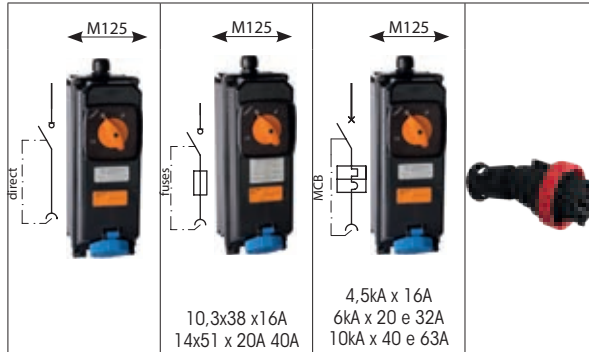

TUV CERTIFICATES WIRED BY THE INSTALLER

Dusts zone 21 - 22

538800
1 socket

538802
2 sockets

DUST ZONE 21-22								
16A	230V	2P+≋	M25	●	467126EX	463126EX	464220EX	760126EX
	400V	3P+≋	M25	●	467136EX	463136EX	464330EX	760136EX
	400V	3P+N+≋	M25	●	467146EX	463146EX	464430EX	760146EX
32A	230V	2P+≋	M32	●	470226EX	472621EX	464621EX	760226EX
	400V	3P+≋	M32	●	470236EX	472731EX	464731EX	760236EX
	400V	3P+N+≋	M32	●	470246EX	472831EX	464831EX	760246EX
63A	400V	3P+≋	M40	●	470336EX	472732EX	464732EX	760336EX
	400V	3P+N+≋	M40	●	470346EX	472832EX	464832EX	760346EX

Gas Zone 2 from 16A to 32A

538800
1 socket

538802
2 sockets

Common equipment for dust and gas: cable gland in technopolymer

GAS ZONE 2								
16A	230V	2P+≋	M25	●	467126EX	463126EX	464220EX	760126EX
	400V	3P+≋	M25	●	467136EX	463136EX	464330EX	760136EX
	400V	3P+N+≋	M25	●	467146EX	463146EX	464430EX	760146EX
20A	230V	2P+≋	M32	●		472621EX		760226EX
	400V	3P+≋	M32	●		472731EX		760236EX
	400V	3P+N+≋	M32	●		472831EX		760246EX
32A	230V	2P+≋	M40	●	470226EX		464621EX	760226EX
	400V	3P+≋	M40	●	470236EX		464731EX	760236EX
	400V	3P+N+≋	M40	●	470246EX		464831EX	760246EX
40A	400V	3P+≋	M40	●		463336EX	464336EX	760336EX
	400V	3P+N+≋	M40	●		463346EX	464346EX	760346EX
63A	400V	3P+≋	M40	●	470336EX			760336EX
	400V	3P+N+≋	M40	●	470346EX			760346EX

Gas Zone 2 32A to 63A

538800
1 socket

538804
2 sockets

COMMON ACCESSORIES

Fitting

- 538421EX** M25
- 538429EX** M32
- 538436EX** M40

Box

- 532240EX** 125x185 x 1 socket
- 532242EX** 250x185 x 2sockets
- 532244EX*** 380x185 x 2 sockets

Plate

- 538800** 125x360 x 1 socket
- 538802** 250x630 x 2 sockets
- 538804*** 380x630 x 2 sockets

* For 3 sockets only certified and wired by Palazzoli

ALUPRES-EX Series

Zones 2, 21, 22

INTERLOCKED SOCKETS IN ALUMINIUM ALLOY



ZONE	GAS			DUST		
	0	1	2	20	21	22
USABLE			X		X	X

Wall-mounted interlocked socket-outlets in aluminium alloy suitable for applications in explosion hazardous areas as defined in ATEX Directive 2014/34/UE. Back box and cover are treated with ecological anticorrosion passivation with fluoro-zirconium treatment and finished with hot polymerised scratch-resistant, non-ageing, non-toxic polyester painting. The colour of the socket is RAL 9005 black. The interlock mechanism is made of metal, and the switch is an AC23A-AC3 class switch at rated current with conditional short-circuit current $\geq 10\text{kA}$. The cover is attached to the back box by means of stainless steel screws, the sealing is guaranteed by a gasket in non-ageing elastomer. Supplied with flange with cable gland in thermoplastic material.

Rated operating current:		16A	32A	40A 63A
Thermal current Ith	A	16	32	63
AC21A	A	16	32	63
AC22A	A	16	32	63
AC23A	A	16	32	63
AC23A	230V	4,5	8,5	20
	400V	7,5	15	34
	500V	8,5	17	44
AC3	230V	4,5	8,5	18
	400V	7,5	15	31
	500V	8,5	17	40

Wiring data:		16A	32A	40A 63A
Entry cable diameters	mm	12 - 18	16 - 25	
Entry cable sections	mm ²	1 - 10		6 - 16
Tightening torque	Nm	2		

Compliance with standards	Directive ATEX 2014/34/EU EN 60079-0 EN 60079-15 EN 60079-31 Directive LVD 2014/35/EU EN 60309-1 EN 60309-2 EN 60309-4
ATEX execution	Ex II 3G 2D (Sockets) Ex nR IIC T6 Gc Ex tb IIIC T 65°C...85°C Db (table on page 15) (boxes) Ex nR IIC Gc Ex tb IIIC Db
Material	Aluminium alloy
Surface treatment	Passivation with fluoro-zirconium treatment
Paint	Hot polymerised non-toxic non-ageing polyester
Colour	RAL 9005 (black)
Protection rating (IP according to IEC/EN 60529)	IP66
Rated current	16A - 32A - 63A
Operating Voltage	110V - 500V
Operating frequency	50-60Hz
Conditional short-circuit current - isolator switch	$\geq 10\text{kA}$
Insulation voltage	500V
Insulation class	I
Operating temperature	-40°C ÷ +65°C -40°C ÷ +40°C sockets with fuse-holder (table on page 16)



Technical data sheets updated to new standards on palazzoli.com website



TABLE OF AMBIENT TEMPERATURES AND ATEX MARKINGS

Version	In	Ambient temperature	Temperature class	Maximum surface temperature	Cable temperature
DUST					
Direct	16A	-40°C ÷ +60°C	-	T70°C	-
		-40°C ÷ +65°C		T75°C	85°C
	32A	-40°C ÷ +50°C		T70°C	-
		-40°C ÷ +65°C		T85°C	95°C
	63A	-40°C ÷ +45°C		T70°C	-
-40°C ÷ +55°C		T80°C	90°C		
Fuse	16A	-40°C ÷ +40°C	T65°C	-	-
	32A		T75°C		
	63A		T80°C		
GAS					
Direct	16A	-40°C ÷ +60°C	T6	-	-
		-40°C ÷ +65°C			85°C
	32A	-40°C ÷ +50°C			-
		-40°C ÷ +65°C			95°C
	63A	-40°C ÷ +45°C			-
-40°C ÷ +55°C		90°C			
Fuse	16A	-40°C ÷ +40°C	-	-	-
	20A				
	40A				

TABLE OF THE MAXIMUM DISSIPATED POWER OF THE BOXES FOR SETS OF SOCKETS

Palazzoli code	-40 ÷ +40°C (W)	-40 ÷ +45°C (W)	-40 ÷ +50°C (W)	-40 ÷ +55°C (W)	-40 ÷ +60°C (W)	-40 ÷ +65°C (W)
DUST						
511914EX	20	17	13	10	7	3
511919EX	42	35	28	21	14	7
GAS						
511914EX	13	13	13	10	7	3
511919EX	25	24	24	21	14	7

Boxes on page 17

TABLE FOR THE SELECTION OF PLUGS THAT CAN BE COMBINED WITH THE SOCKETS FOR ZONE 2

Rated current		
Socket-outlet with fuses	Socket-outlet without protection	Plug
16A	16A	16A
32A	32A	32A
40A	63A	63A

SUITABLE FOR ZONES 21-22 (DUST)

MODULE 125



Modular interlocked socket-outlets in aluminium alloy for wall-mounting 50-60Hz **IP66**

Rated current (A)	Rated voltage (V)	Voltage colour	Poles	h. ref.	Palazzoli code	Pack Qty	
16	110	Yellow	2P+⊕	4	466124EX	1	
	entry M25	110	Yellow	3P+⊕	4	466134EX	1
		110	Yellow	3P+N+⊕	4	466144EX	1
	230	Blue	2P+⊕	6	466126EX	1	
	230	Blue	3P+⊕	9	466139EX	1	
	230	Blue	3P+N+⊕	9	466149EX	1	
	400	Red	2P+⊕	9	466129EX	1	
	400	Red	3P+⊕	6	466136EX	1	
	400	Red	3P+N+⊕	6	466146EX	1	
	500	Black	3P+⊕	7	466137EX	1	
500	Black	3P+N+⊕	7	466147EX	1		
32	110	Yellow	2P+⊕	4	460224EX	1	
	entry M32	110	Yellow	3P+⊕	4	460234EX	1
		110	Yellow	3P+N+⊕	4	460244EX	1
	230	Blue	2P+⊕	6	460226EX	1	
	230	Blue	3P+⊕	9	460239EX	1	
	230	Blue	3P+N+⊕	9	460249EX	1	
	400	Red	2P+⊕	9	460229EX	1	
	400	Red	3P+⊕	6	460236EX	1	
	400	Red	3P+N+⊕	6	460246EX	1	
	500	Black	3P+⊕	7	460237EX	1	
500	Black	3P+N+⊕	7	460247EX	1		
63	110	Yellow	2P+⊕	4	460324EX	1	
	entry M32	110	Yellow	3P+⊕	4	460334EX	1
		110	Yellow	3P+N+⊕	4	460344EX	1
	230	Blue	2P+⊕	6	460326EX	1	
	230	Blue	3P+⊕	9	460339EX	1	
	230	Blue	3P+N+⊕	9	460349EX	1	
	400	Red	2P+⊕	9	460329EX	1	
	400	Red	3P+⊕	6	460336EX	1	
	400	Red	3P+N+⊕	6	460346EX	1	
	500	Black	3P+⊕	7	460337EX	1	
500	Black	3P+N+⊕	7	460347EX	1		

Equipment included: flange F1 with technopolymer cable gland on the upper side. Steel blind flange on bottom side.
Technical accessories: enclosures for compositions at page 17. Steel backplate at page 17.

SUITABLE FOR ZONES 21-22 (DUST)

MODULE 125



Modular interlocked socket-outlets in aluminium alloy with **fuse-holder base** for wall-mounting 50-60Hz **IP66**

Rated current (A)	Rated voltage (V)	Voltage colour	Poles	h. ref.	Palazzoli code	Pack Qty
16	110	Yellow	2P+⊕	4	465124EX	1
entry M25 fuses 10,3x38	110	Yellow	3P+⊕	4	465134EX	1
	110	Yellow	3P+N+⊕	4	465144EX	1
	230	Blue	2P+⊕	6	465126EX	1
	230	Blue	3P+⊕	9	465139EX	1
	230	Blue	3P+N+⊕	9	465149EX	1
	400	Red	2P+⊕	9	465129EX	1
	400	Red	3P+⊕	6	465136EX	1
	400	Red	3P+N+⊕	6	465146EX	1
	500	Black	3P+⊕	7	465137EX	1
	500	Black	3P+N+⊕	7	465147EX	1
32 entry M32 fuses 14x51	110	Yellow	2P+⊕	4	472236EX	1
	110	Yellow	3P+⊕	4	472246EX	1
	110	Yellow	3P+N+⊕	4	472256EX	1
	230	Blue	2P+⊕	6	472336EX	1
	230	Blue	3P+⊕	9	472346EX	1
	230	Blue	3P+N+⊕	9	472356EX	1
	400	Red	2P+⊕	9	472436EX	1
	400	Red	3P+⊕	6	472446EX	1
	400	Red	3P+N+⊕	6	472456EX	1
	500	Black	3P+⊕	7	472546EX	1
63 entry M32 fuses E33 DIII	110	Yellow	2P+⊕	4	472237EX	1
	110	Yellow	3P+⊕	4	472247EX	1
	110	Yellow	3P+N+⊕	4	472257EX	1
	230	Blue	2P+⊕	6	472337EX	1
	230	Blue	3P+⊕	9	472347EX	1
	230	Blue	3P+N+⊕	9	472357EX	1
	400	Red	2P+⊕	9	472437EX	1
	400	Red	3P+⊕	6	472447EX	1
	400	Red	3P+N+⊕	6	472457EX	1
	500	Black	3P+⊕	7	472547EX	1
500	Black	3P+N+⊕	7	472557EX	1	

Equipment included: flange F1 with technopolymer cable gland on the upper side. Steel blind flange on bottom side.
Features: fuses not included.
Technical accessories: enclosures for compositions at page 17. Steel backplate at page 17.

SUITABLE FOR ZONE 2 (GAS)

MODULE 125



Modular interlocked socket-outlets in aluminium alloy for wall-mounting 50-60Hz **IP66**

Rated current (A)	Rated voltage (V)	Voltage colour	Poles	h. ref.	Palazzoli code	Pack Qty
16 entry M25	110	Yellow	2P+⊕	4	466124EX	1
	110	Yellow	3P+⊕	4	466134EX	1
	110	Yellow	3P+N+⊕	4	466144EX	1
	230	Blue	2P+⊕	6	466126EX	1
	230	Blue	3P+⊕	9	466139EX	1
	230	Blue	3P+N+⊕	9	466149EX	1
	400	Red	2P+⊕	9	466129EX	1
	400	Red	3P+⊕	6	466136EX	1
	400	Red	3P+N+⊕	6	466146EX	1
	500	Black	3P+⊕	7	466137EX	1
32 entry M32	110	Yellow	2P+⊕	4	460224EX	1
	110	Yellow	3P+⊕	4	460234EX	1
	110	Yellow	3P+N+⊕	4	460244EX	1
	230	Blue	2P+⊕	6	460226EX	1
	230	Blue	3P+⊕	9	460239EX	1
	230	Blue	3P+N+⊕	9	460249EX	1
	400	Red	2P+⊕	9	460229EX	1
	400	Red	3P+⊕	6	460236EX	1
	400	Red	3P+N+⊕	6	460246EX	1
	500	Black	3P+⊕	7	460237EX	1
63 entry M32	110	Yellow	2P+⊕	4	460324EX	1
	110	Yellow	3P+⊕	4	460334EX	1
	110	Yellow	3P+N+⊕	4	460344EX	1
	230	Blue	2P+⊕	6	460326EX	1
	230	Blue	3P+⊕	9	460339EX	1
	230	Blue	3P+N+⊕	9	460349EX	1
	400	Red	2P+⊕	9	460329EX	1
	400	Red	3P+⊕	6	460336EX	1
	400	Red	3P+N+⊕	6	460346EX	1
	500	Black	3P+⊕	7	460337EX	1
500	Black	3P+N+⊕	7	460347EX	1	

Equipment included: flange F1 with insulated cable gland on the top side. Steel blind flange on the bottom side.
Technical accessories: enclosures for compositions at page 17. Steel backplate at page 17.

EX-AGENCIA CERTIFIED AND WIRED BY THE INSTALLER

**Dusts Zone 21 - 22
Gas Zone 2
from 16A to 63A**

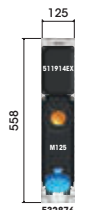

1 socket

**DUSTS ZONE 21 - 22
FROM 16A-32A**

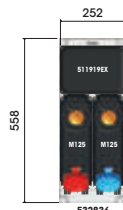

2 sockets

**Gas Zone 2
from 16A-25A**

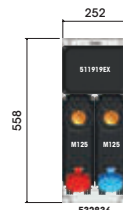

2 sockets

**Dusts Zone 21 - 22
Gas Zone 2
from 16A to 63A**

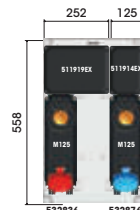

2 sockets



SUITABLE FOR ZONE 2 (GAS)

MODULE 125



Modular interlocked socket-outlets in aluminium alloy with **fuse-holder base** for wall-mounting 50-60Hz **IP66**

Rated current (A)	Rated voltage (V)	Voltage colour	Poles	h. ref.	Palazzoli code	Pack Qty
16 entry M25 fuses 10.3x38	110	●	2P+⊕	4	465124EX	1
	110	●	3P+⊕	4	465134EX	1
	110	●	3P+N+⊕	4	465144EX	1
	230	●	2P+⊕	6	465126EX	1
	230	●	3P+⊕	9	465139EX	1
	230	●	3P+N+⊕	9	465149EX	1
	400	●	2P+⊕	9	465129EX	1
	400	●	3P+⊕	6	465136EX	1
	400	●	3P+N+⊕	6	465146EX	1
	500	●	3P+⊕	7	465137EX	1
32 entry M32 fuses 14x51	110	●	2P+⊕	4	472236EX	1
	110	●	3P+⊕	4	472246EX	1
	110	●	3P+N+⊕	4	472256EX	1
	230	●	2P+⊕	6	472336EX	1
	230	●	3P+⊕	9	472346EX	1
	230	●	3P+N+⊕	9	472356EX	1
	400	●	2P+⊕	9	472436EX	1
	400	●	3P+⊕	6	472446EX	1
	400	●	3P+N+⊕	6	472456EX	1
	500	●	3P+⊕	7	472546EX	1
40 entry M32 fuses 14x51	110	●	2P+⊕	4	465324EX	1
	110	●	3P+⊕	4	465334EX	1
	110	●	3P+N+⊕	4	465344EX	1
	230	●	2P+⊕	6	465326EX	1
	230	●	3P+⊕	9	465339EX	1
	230	●	3P+N+⊕	9	465349EX	1
	400	●	2P+⊕	9	465329EX	1
	400	●	3P+⊕	6	465336EX	1
	400	●	3P+N+⊕	6	465346EX	1
	500	●	3P+⊕	7	465337EX	1
500	●	3P+N+⊕	7	465347EX	1	

Equipment included: flange F1 with insulated cable gland on the top side. Steel blind flange on the bottom side.

Characteristics: fuses not included.

Technical accessories: enclosures for compositions at page 17. Steel backplate at page 17.

Notes: n. 2 sockets of 32A when flanked in a composition of socket boards can be used up to 25A.



Device for testing the **restricted breathing** of the sockets

Socket rated current	No. of poles	Palazzoli code	Pack Qty
16A	2P+⊕	478126	1
	3P+⊕	478136	1
	3P+N+⊕	478146	1
20A/32A	2P+⊕/3P+⊕	478206	1
	3P+N+⊕	478246	1
40A/63A	2P+⊕/3P+⊕/3P+N+⊕	478306	1

Equipment included: transparent tube to be applied to the testing device.

Instructions: insert the testing device into the socket-outlet (test port), tighten the device's shade ring and do the testing according to Art. 33.7.1 of EN60079-15 Standards with the suitable measuring device.

SUITABLE FOR ZONE 2 (GAS) AND 21-22 (DUST)



Boxes in aluminium alloy with blind cover for composition of socket boards **IP66**

Outer dimensions (mm)	Power dissipation Ta = +40°C* (W)		Window type	Palazzoli code	Pack Qty
	Gas	Dust			
125x125	13	20		511914EX	1
252x125	25	42		511919EX	1

Equipment included: the code 511919Ex is equipped with windowed flange and M32 cable gland. Back plate in galvanised steel.

Screws for internal and external earth connection.

*For Ta values >40°C see table on page 15.



Mounting plate in painted steel for composition of socket boards

Outer dimensions (mm)	No. of installable devices	Palazzoli code	Pack Qty
125x558	1	532876	1
250x558	2	532836	1



Flanges in aluminium alloy with metric threading for windowed boxes **IP67**

For windows	Threading type	Projection (mm)	Palazzoli code	Pack Qty
F1	M25	18	541055EX	1
F1	M32	51	540180EX	1
F2	M32	51	540185EX	1
F2	M40	51	540186EX	1

Complementary items: cable glands at page 24.

TAIS-EX Series

Zones 1, 2, 21, 22

BOXES IN ANTISTATIC THERMOSETTING (GRP)



ZONE	GAS			DUST		
	0	1	2	20	21	22
USABLE		X	X		X	X

Modular watertight boxes in Palazzoli antistatic thermosetting GRP, suitable for use in explosion hazardous areas as provided for in the ATEX Directive ATEX 2014/34/EU.

The cover is attached to the back box by means of stainless steel screws while the sealing is guaranteed by a gasket in non-ageing elastomer. The boxes are prepared for the installation of a DIN EN50022 rail for mounting modular terminal blocks and a back plate in anti-corrosion galvanised tropicalised steel.

Table of the max. power dissipation allowed for TAIS-EX boxes

Code	40°C ÷ +40°C (W)	40°C ÷ +50°C (W)	40°C ÷ +60°C (W)	40°C ÷ +70°C (W)	40°C ÷ +75°C (W)
532200EX	18	12	8	4	2
532201EX	19	17	11	6	3
532202EX	23	22	15	7	4
532203EX	24	22	17	8	4
532204EX	25	25	23	15	8
532035EX*	8	6	4	2	1
532045EX	10	6	4	2	1
532055EX	12	9	6	3	1
532116EX	13	10	7	3	2
532117EX	15	10	7	3	2
532118EX	20	14	9	5	2
532005EX	11	10	7	3	2
532006EX	11	7	4	2	1
532015EX	16	9	6	3	2
532016EX	15	10	7	3	2
532017EX	17	13	8	4	2
532018EX	22	22	15	7	4

*The minimum operating temperature is -20° C.

The marking of the empty ATEX boxes does not show the temperature class T of the equipment since the maximum service temperature, for the protection mode "e" (gas), depends on the temperature reached by the components mounted inside (terminals, fuse holder, etc.); while for the "tb" (dust) protection mode, the maximum surface temperature of the external casing of the box depends on the effective power dissipated by the internal components.

The user must choose the most suitable box based on the calculation of the dissipated power of the internal components and the operating temperature indicated in the table above and proceed with the certification of the assembly thus constructed.

Compliance with standards
ATEX Directive 2014/34/EU
EN 60079-0
EN 60079-7
EN 60079-31

Directive 2014/35/EU
EN 62208

ATEX execution
Ex II 2G 2D
Ex e IIC Gb
Ex tb IIIC Db

Material Palazzoli antistatic thermosetting GRP

Surface resistance (prevention of electrostatic charge accumulation)
< 10⁹ Ω

Protection rating (IP according to IEC/EN 60529)
IP66

Colour RAL 9005 (black)

Resistance to abnormal heat and fire ("Glow wire" according to IEC/EN 60695-2-10)
960°C

Flammability rating (according to UL94)
V0

Insulation class II

Operating temperature
-40°C ÷ +40°C
-40°C ÷ +50°C
-40°C ÷ +60°C
-40°C ÷ +70°C
-40°C ÷ +75°C
(see table to the side)



Technical data sheets updated to new standards on palazzoli.com website

SUITABLE FOR ZONES 1-2 (GAS) AND 21-22 (DUST)



Junction boxes
in thermosetting GRP
quick assembly
IP66

Outer dimensions (mm)	Max. power dissipation (W)	Palazzoli code	Pack Qty
125x185x125	18	532200EX	1
190x185x125	19	532201EX	1
250x185x125	23	532202EX	1
290x185x125	24	532203EX	1
380x185x125	25	532204EX	1

Notes: the maximum power dissipation is for the maximum ambient temperature of 40°C.



Junction boxes
in thermosetting GRP
with **low cover**
IP66

Outer dimensions (mm)	Max. power dissipation (W)	Palazzoli code	Pack Qty
92x92x68	8	532035EX*	1
125x92x68	10	532045EX	1
185x92x68	12	532055EX	1
125x125x100	13	532116EX	1
185x125x100	15	532117EX	1
250x125x100	20	532118EX	1

Notes: the maximum power dissipation is for the maximum ambient temperature of 40°C.

*The minimum operating temperature is -20 °C.



Junction boxes
in thermosetting GRP
with **high cover**
IP66

Outer dimensions (mm)	Max. power dissipation (W)	Palazzoli code	Pack Qty
92x92x100	11	532005EX	1
125x92x100	11	532006EX	1
185x92x100	16	532015EX	1
125x125x125	15	532016EX	1
185x125x125	17	532017EX	1
250x125x125	22	532018EX	1

Notes: the maximum power dissipation is for the maximum ambient temperature of 40°C.

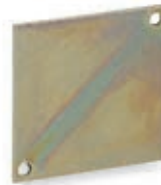

Back plates
in galvanised steel
for TAIS boxes

For enclosure code	Plate dimensions (mm)	Palazzoli code	Pack Qty
532035EX-532005EX	59x59	532705	1
532045EX-532006EX	92x58	532714	1
532055EX-532015EX	142x62	532715	1
532116EX-532016EX	86x86	532716	1
532117EX-532017EX	100x86	532717	1
532118EX-532018EX	175x86	532718	1
532200EX-532240EX	95x145	532700	1
532201EX	160x145	532701	1
532202EX-532242EX	220x145	532702	1
532203EX	260x145	532703	1
532204EX-532244EX	333x145	532704	1



Milling cutters
cup shaped in steel
for quick drill connection
tungsten carbide
gear teeth specific
for thermosetting GRP

Hole type	Diameter (mm)	Palazzoli code	Pack Qty
M20 - M25 - M32 - M40	20,5 - 25,5 - 32,5 - 40,5	538410	1

ALUPRES-EX Series

Zones 1, 2, 21, 22

BOXES IN ALUMINIUM ALLOY



	GAS			DUST		
ZONE	0	1	2	20	21	22
USABLE		X	X		X	X

Watertight boxes in aluminium alloy suitable for applications in explosion hazardous areas as defined in ATEX Directive 2014/34/UE.

Back box and cover are treated with ecological anticorrosion passivation with fluoro-zirconium treatment and finished with hot polymerised scratch resistant, non-ageing, non-toxic polyester painting. The colour of the box is RAL 9005 black. The cover is attached to the back box by means of stainless steel screws while the sealing is guaranteed by a gasket in non-ageing elastomer.

Designed to enable internal and external earthing.

Table of the max. power dissipation allowed for ALUPRES-EX boxes

Code	-40°C ÷ +40°C (W)	-40°C ÷ +50°C (W)	-40°C ÷ +60°C (W)	-40°C ÷ +65°C (W)
511910EX*	10	7	4	2
511913EX	20	13	7	3
150021EX	30	16	8	4
511920EX	40	24	12	6
511921EX	42	28	14	7
511911EX	12	10	5	2
511912EX	23	13	6	3
511917EX	40	23	11	6
511922EX	45	25	13	6
511923EX	65	40	20	10

*The minimum operating temperature is -20° C.

The marking of the empty ATEX boxes does not show the temperature class T of the equipment since the maximum service temperature, for the protection mode "e" (gas), depends on the temperature reached by the components mounted inside (terminals, fuse holder, etc.); while for the "tb" (dust) protection mode, the maximum surface temperature of the external casing of the box depends on the effective power dissipated by the internal components.

The user must choose the most suitable box based on the calculation of the dissipated power of the internal components and the operating temperature indicated in the table above and proceed with the certification of the assembly thus constructed.

Compliance with standards
Directive ATEX 2014/34/EU
EN 60079-0
EN 60079-7
EN 60079-31

Directive ATEX 2014/35/EU
EN 62208

ATEX execution
Ex II 2G 2D
Ex e IIC Gb
Ex tb IIIC Db

Material **Aluminium alloy**

Surface treatment **Passivation with fluoro-zirconium treatment**

Paint **Hot polymerised non-toxic non-ageing polyester**

Colour **RAL 9005 (black)**

Protection rating (IP according to IEC/EN 60529) **IP66**

Insulation class **I**

Operating temperature
-40°C ÷ +40°C
-40°C ÷ +50°C
-40°C ÷ +60°C
-40°C ÷ +65°C
 (see table to the side)



Technical data sheets updated to new standards on palazzoli.com website

SUITABLE FOR ZONES 1-2 (GAS) AND 21-22 (DUST)



Junction boxes in aluminium alloy with **blind walls** and back plate **IP66**

Outer dimensions (mm)	Max. power dissipation (W)	Palazzoli code	Pack Qty
92x92x77	10	511910EX*	1
125x125x113	20	511913EX	1
155x155x73	30	150021EX	1
185x185x145	40	511920EX	1
252x185x145	42	511921EX	1

Equipment included: earth screws inside and outside the box. Back plate (except code 511910EX).

Notes: the maximum power dissipation is for the maximum ambient temperature of 40°C.

*The minimum operating temperature is -20 °C.



Junction boxes in aluminium alloy with **flanged walls** and back plates **IP66**

Outer dimensions (mm)	Max. power dissipation (W)	Window type	Palazzoli code	Pack Qty
125x92x77	12		511911EX	1
185x92x77	23		511912EX	1
252x125x113	40		511917EX	1
220x220x108	45		511922EX	1
252x252x197	65		511923EX	1

Equipment included: earth screws inside and outside the box. Blind flat flanges.

Back plate (except codes 511911EX and 511912EX).

Notes: the maximum power dissipation is for the maximum ambient temperature of 40°C.



Flanges in aluminium alloy with metric threading for windowed boxes **IP66**

For windows	Threading type	Projection (mm)	Palazzoli code	Pack Qty
F0	M25x1,5	18	541050EX	1
F1	M25x1,5	18	541055EX	1
F1	M32x1,5	51	540180EX	1
F3	M40x1,5	51	540190EX	1
F5	M50x1,5	51	540195EX	1

Technical accessories: cable glands at page 24.



Closing flanges raised in aluminium alloy for windowed boxes **IP66**

For windows	Projection (mm)	Palazzoli code	Pack Qty
F1	32	540061EX	1
F3	50	540063EX	1
F5	80	540065EX	1

CUSTOMISED ATEX JUNCTION BOXES

TAIS-EX thermosetting GRP enclosures and ALUPRES-EX aluminium enclosures can be completed with cable glands and terminals, to create customised terminal enclosures, suitable to be installed in zone 1,2, 21 and 22, in compliance with the ATEX Directive 2014/34/EU. The configurations customised and certified by a Notified Organism can be made by Palazzoli upon specifications of the customer.

To make the configurations it is necessary to know:

1. Number and type of modular terminal blocks

The EN50022 rail inside the box can be completed with modular terminal blocks complying with the Atex Directive and certified according to protection mode Ex-e. The maximum number of usable terminals depends on the physical dimensions of the box, according to the table below, and on the maximum power dissipation.

2. Number, type and dispositions of the cable glands

Each enclosure can be drilled on the 4 sides using a max. number of entries that depends on the dimensions of the cable glands and on side area. Cable glands from Palazzoli or any other brand, from M12 to M50, may be used. They must comply with the ATEX Directive and certified with the Ex-e/Ex-tb protection mode. If windowed boxes are used, it is possible to complete them with suitable perforated flanges or blind raised flanges (Table below).

SERIES	CODE OF EMPTY BOX	DIMENSIONS (BxHxP)	DIN GUIDE LENGTH (mm)	MAXIMUM NUMBER OF CABLE GLANDS THAT CAN BE INSTALLED ON EACH SIDE													
				LONG SIDE OF THE BOX (B)							SHORT SIDE OF THE BOX (H)						
				M12	M16	M20	M25	M32	M40	M50	M12	M16	M20	M25	M32	M40	M50
TAIS-EX	532200EX	185x125x125	145	12	8	6	3	2	2	-	6	4	3	2	1	1	-
	532201EX	190x185x125	160	12	8	6	3	2	2	-	12	8	6	3	2	2	-
	532202EX	250x185x125	220	16	14	12	5	4	3	-	12	8	6	3	2	2	-
	532203EX	290x185x125	260	20	16	14	6	5	4	-	12	8	6	3	2	2	-
	532204EX	380x185x125	333	26	24	22	9	7	6	-	12	8	6	3	2	2	-
	532035EX	92x92x68	59	2	1	1	-	-	-	-	2	1	1	-	-	-	-
	532045EX	125x92x68	92	4	3	3	2	-	-	-	2	1	1	-	-	-	-
	532055EX	185x92x68	142	6	4	4	2	-	-	-	2	1	1	-	-	-	-
	532116EX	125x125x100	86	7	4	3	2	1	1	-	6	4	3	2	1	1	-
	532117EX	185x125x100	100	12	8	6	3	2	2	1	6	4	3	2	1	1	-
	532118EX	250x125x100	175	16	14	12	6	4	3	-	6	4	3	2	1	1	-
	532005EX	92x92x100	59	2	1	1	-	-	-	-	2	1	1	-	-	-	-
	532006EX	125x92x100	92	4	3	3	2	-	-	-	2	1	1	-	-	-	-
	532015EX	185x92x100	142	6	4	4	2	-	-	-	2	1	1	-	-	-	-
	532016EX	125x125x125	86	7	5	4	2	1	-	-	6	5	4	2	1	-	-
	532017EX	185x125x125	100	12	7	6	4	3	-	-	6	5	4	2	1	-	-
532018EX	250x125x125	175	16	10	8	5	4	-	-	6	5	4	2	1	-	-	
ALUPRES-EX	511910EX	92x92x77	69	3	2	2	1	-	-	3	2	2	1	-	-	-	
	511913EX	125x125x113	100	8	5	4	2	2	-	8	5	4	2	2	-	-	
	150021EX	155x155x73	122	10	6	5	3	1	-	10	6	5	3	1	-	-	
	511920EX	185x185x145	160	18	12	10	8	4	3	2	18	12	10	8	4	3	2
	511921EX	252x185x145	200	24	16	14	10	5	4	3	18	12	10	8	4	3	2
	511911EX	125x92x77	100	3	3	2	-	-	-	-	-	-	-	-	-	-	-
	511912EX	185x92x77	150	6	5	4	-	-	-	-	-	-	-	-	-	-	-
	511917EX	252x125x113	200	16	14	6	5	4	-	-	2	1	-	-	-	-	-
	511922EX	220x220x108	190	3	3	2	2	-	-	-	3	3	2	2	-	-	-
	511923EX	252x252x197	210	32	28	18	10	8	6	3	15	8	6	6	2	2	1

3. Maximum operating current for each terminal

By specifying this value, the maximum power dissipation can be calculated more precisely, with the possibility to optimize the box dimensions. In case this value will not be available, the maximum rated current will be considered by increasing the dimensions of the box to be used.

4. Ambient temperature

Palazzoli's thermosetting GRP boxes of the TAIS-EX series and aluminium alloy boxes of the ALUPRES-EX series can be used at different temperatures. The complete tables are on page 18 for the TAIS-EX series and page 20 for the ALUPRES-EX series. Also in this case, by carefully choosing the temperature range, it is possible to use optimised boxes with more compact dimensions.

REQUEST FORM FOR CUSTOMISED ATEX JUNCTION BOXES

DATA REQUIRED

CODE OF EMPTY PALAZZOLI BOX: _____

QUANTITY TO BE PRODUCED: _____

MAX AMBIENT TEMPERATURE (°C): _____

BRAND OF TERMINAL: _____

(if not expressly indicated, the terminals are the responsibility of Palazzoli)

INTERNAL COMPOSITION	TERMINAL RATED CROSS-SECTION (mm ²)						
	2,5	4	6	10	16	25	35
NUMBER OF TERMINALS							
CURRENT PER TERMINAL (A)							

Indicate in the table the number of terminals and the current required for each terminal.

CABLE GLAND MATERIAL: Insulating Brass

BRAND OF CABLE GLAND: _____

(if not expressly indicated, the cable glands are the responsibility of Palazzoli)

EXTERNAL COMPOSITION	CABLE GLAND THREAD						
	M12	M16	M20	M25	M32	M40	M50
NUMBER OF CABLE GLANDS							

Indicate in the table the number of cable glands and their positions on the four sides of the box as in the example below.

Example:

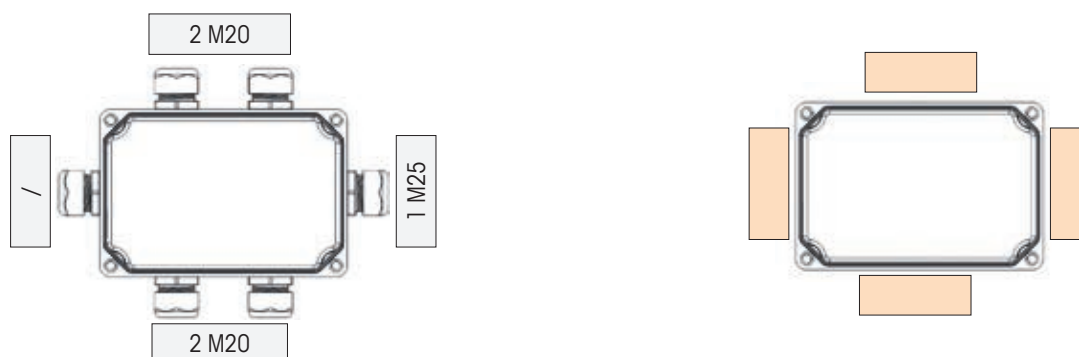

The form must be sent to export@palazzoli.com or by fax to **+39 030 2015.258**.

UNI-EX Series

Zones 1, 2, 21, 22

CABLE GLANDS AND ADAPTORS



ZONE	GAS			DUST		
	0	1	2	20	21	22
USABLE		X	X		X	X

Cable glands in technopolymer and nickel-plated brass with neoprene gaskets.

Galvanised steel adaptors with Pg or Gas male thread and female metric thread to connect devices of different standards.

The products are suitable for use in explosion hazardous areas according to ATEX directive 2014/34/EU.

Compliance with standards
 Directive ATEX 2014/34/EU
 EN 60079-0
 EN 60079-7
 EN 60079-31
 IEC/EN 60079-0
 IEC/EN 60079-1
 IEC/EN 60079-7
 IEC/EN 60079-31
 ISO 965-1
 ISO 965-3

ATEX execution
 (cable glands)
 Ex e IIC, Ex tb IIIC
 (cable glands for armoured cables)
 Ex db/eb IIC, Ex tb IIIC
 (adaptors)
 Ex d IIC, Ex e IIC, Ex tb IIIC

Material
 (technopolymer cable glands)
 Polyamide body
 Neoprene gaskets
 (brass cable glands)
 Nickel-plated brass body
 Neoprene gaskets
 (cable glands for armoured cables)
 Nickel-plated brass body
 Graphite gasket
 (adaptors)
 Galvanised steel

Colour
 Technopolymer cable gland
 RAL 9005 (black)

Protection rating
 IP66/IP68 (cable glands)
 IP66/IP67 (adaptors)

Operating temperature
 (technopolymer cable glands)
 -20°C - +80°C (M12)
 -35°C - +95°C
 (brass cable glands)
 -40°C - +100°C
 (cable glands for armoured cables)
 -60°C - +80°C
 (adaptors)
 -40°C - +150°C



Technical data sheets updated to new standards on palazzoli.com website

SUITABLE FOR ZONES 1-2 (GAS) AND 21-22 (DUST)



Cable glands
in insulating material
with **Pg threading**
IP66/IP68

Pg	Mounting hole (mm)	Fastening diameter (mm)	Thread length (mm)	Palazzoli code	Pack Qty
9	16	3,5-8,5	8	571009EX	50
11	19	4-10,5	8	571011EX	50
13,5	21	5-12,5	9	571013EX	50
16	23	6,5-14	10	571016EX	50
21	29	8-18,5	11	571021EX	20
29	38	10-25	12	571029EX	20
36	48	24-34	15	571036EX	10
42	55	34-42	15	571042EX	5
48	61	40-48	15	571048EX	5



Locknuts
in insulating material
with **Pg threading**

Pg	Palazzoli code	Pack Qty
9	571209	50
11	571211	50
13,5	571213	50
16	571216	50
21	571221	25
29	571229	20
36	571236	10
42	571242	5
48	571248	5



Cable glands
in insulating material
with **Pg pitch**
with **long thread**
IP66/IP68

Pg	Mounting hole (mm)	Fastening diameter (mm)	Thread length (mm)	Palazzoli code	Pack Qty
9	16	3,5-5,5	15	571109EX	50
11	19	4-10,5	15	571111EX	50
13,5	21	5-12,5	15	571113EX	50
16	23	6,5-14	15	571116EX	50
21	29	8-18,5	15	571121EX	20
29	38	10-25	15	571129EX	20
36	48	24-34	18	571136EX	10
42	55	34-42	18	571142EX	5
48	61	40-48	18	571148EX	5

SUITABLE FOR ZONES 1-2 (GAS) AND 21-22 (DUST)



Cable glands
in insulating material
with **metric threading**
IP66/IP68

Threading	Mounting hole (mm)	Fastening diameter (mm)	Thread length (mm)	Palazzoli code	Pack Qty
M12x1,5	12,5	4-6,5	8	581012EX	50
M16x1,5	16,5	5-10	10	581016EX	50
M20x1,5	20,5	10-14	10	581020EX	50
M25x1,5	25,5	12-18	10	581025EX	20
M32x1,5	32,5	16-25	10	581032EX	20
M40x1,5	40,5	22-32	10	581040EX	20
M50x1,5	50,5	28-38,5	12	581050EX	10
M63x1,5	63,5	40-48	12	581063EX	5



Cable glands
in insulating material
with **metric pitch**
with **long thread**
IP66/IP68

Threading	Mounting hole (mm)	Fastening diameter (mm)	Thread length (mm)	Palazzoli code	Pack Qty
M12x1,5	12,5	4-6,5	15	581112EX	50
M16x1,5	16,5	5-10	15	581116EX	50
M20x1,5	20,5	10-14	15	581120EX	50
M25x1,5	25,5	12-18	15	581125EX	20
M32x1,5	32,5	16-25	15	581132EX	20
M40x1,5	40,5	22-32	16	581140EX	20
M50x1,5	50,5	28-38,5	16	581150EX	10
M63x1,5	63,5	40-48	16	581163EX	5



Locknuts
in insulating material
with **metric threading**

Threading	Palazzoli code	Pack Qty
M12x1,5	581212	50
M16x1,5	581216	50
M20x1,5	581220	50
M25x1,5	581225	50
M32x1,5	581232	50
M40x1,5	581240	20
M50x1,5	581250	10
M63x1,5	581263	5

SUITABLE FOR ZONES 1-2 (GAS) AND 21-22 (DUST)



Cable glands
in nickel-plated brass
with **metric threading**
IP66/IP68

Threading	Mounting hole (mm)	Fastening diameter (mm)	Thread length (mm)	Palazzoli code	Pack Qty
M12x1,5	12,5	4,5-6,5	15	582112EX	50
M16x1,5	16,5	5-9,5	15	582116EX	50
M20x1,5	20,5	8-13	15	582120EX	50
M25x1,5	25,5	9-16	15	582125EX	20
M32x1,5	32,5	12-21	15	582132EX	20
M40x1,5	40,5	16-27	15	582140EX	20
M50x1,5	50,5	23-35	15	582150EX	10
M63x1,5	63,5	36-48	15	582163EX	5



Cable glands for armoured cables
in nickel-plated brass
with **metric threading**
IP66/IP68

Threading	Mounting hole (mm)	Sheath outer diameter (mm)	Sheath inner diameter (mm)	Thread length (mm)	Palazzoli code	Pack Qty
M16	16,5	7-11,5	4-8	15	580416EX	1
M20	20,5	9-15,5	7-12	15	580420EX	1
M25	25,5	13-20	9,5-15,5	15	580425EX	1
M32	32,5	18-27	14-20,5	15	580432EX	1
M40	40,5	23-33,5	17-27	15	580440EX	1
M50	50,5	29-40,5	22-33,5	15	580450EX	1
M63	63,5	40-54	34-47,5	15	580463EX	1

Note: earthing tab available on request.



Locknuts
in nickel-plated brass
with **metric threading**

Threading	Palazzoli code	Pack Qty
M12x1,5	582212	50
M16x1,5	582216	50
M20x1,5	582220	50
M25x1,5	582225	25
M32x1,5	582232	20
M40x1,5	582240	10
M50x1,5	582250	10
M63x1,5	582263	5



Gas/metric adaptors
in galvanised steel
for tube/box connections
IP67

Male thread	Female thread	Palazzoli code	Pack Qty
3/8" Gas	M16x1,5	580360EX	1
1/2" Gas	M20x1,5	580361EX	1
3/4" Gas	M25x1,5	580364EX	1
1" Gas	M32x1,5	580365EX	1



Pg/metric adaptors
in galvanised steel
for tube/box connections
IP67

Male thread	Female thread	Palazzoli code	Pack Qty
Pg21	M25x1,5	580394EX	1
Pg29	M32x1,5	580395EX	1
Pg36	M40x1,5	580396EX	1

SELECTION GUIDE

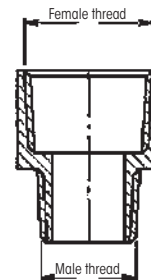

CAM-EX Series

Zones 2, 21, 22

ROTARY CONTROL DEVICES
IN ANTISTATIC THERMOSETTING (GRP)



	GAS			DUST		
ZONE	0	1	2	20	21	22
USABLE			X		X	X

Watertight control devices in Palazzoli antistatic thermosetting GRP suitable for use in explosion hazardous areas as provided for in the ATEX Directive 2014/34/EU.

The cover is attached to the body with stainless steel screws while the sealing is ensured by a gasket in non-ageing elastomer.

Complete with earthing terminal inside the box. The load is of AC23A-AC3 type with rated current with short-circuit conditional current $\geq 10\text{kA}$. Mechanical life of over one million operations.

Rated operating current

			16A	25A	40A	63A
Thermal current I _{th}		A	16	25	40	63
AC21A	415V	A	16	25	40	63
	500V					
AC22A	415V	A	16	25	40	63
	500V					
AC23A	230V	A	16	25	40	63
	400V					
	500V					
AC23A	230V	kW	4,5	7	11	20
	400V		7,5	12	19	34
	500V		8,5	14	23	44
AC3	230V	kW	4,5	7	11	18
	400V		7,5	12	19	31
	500V		8,5	14	23	40

Wiring data:

			16A	25A	40A	63A
Entry cable diameters	mm		12-18		16-25	
Entry cable sections	mm ²		1-10		4-10	6-16
Tightening torque	Nm		2			

Compliance with standards
ATEX Directive 2014/34/EU
EN 60079-0
EN 60079-15
EN 60079-31

Directive LVD 2014/35/EU
EN 60947-3
EN 60947-1

ATEX execution
Ex II 3G 2D

Ex nR IIC T5/T6 Gc
Ex tb IIIC T 85°C Db
(table on page 31)

Casing material
Palazzoli antistatic thermosetting GRP

Surface resistance
<10⁹ Ω
(prevention of electrostatic charge accumulation)

Protection rating (IP according to IEC/EN 60529)
IP66

Colour
RAL 9005 (black)

Resistance to abnormal heat and fire ("Glow wire" according to IEC/EN 60695-2-10)
960°C

Flammability rating (according to UL94)
V0

Rated current
16A - 25A - 40A - 63A

Operating voltage
500V

Operating frequency
50-60Hz

Conditional short-circuit current - isolator switch
 $\geq 10\text{kA}$

Mechanical duration
>1.000.000 operations

Insulation class
II

Operating temperature
-40°C ÷ +65°C
(table on page 31)



Technical data sheets updated to new standards on palazzoli.com website

**TABLE OF AMBIENT TEMPERATURES
AND ATEX MARKINGS**

In	Poles	Ambient temperature	Temperature class	Maximum surface temperature	Cable temperature
DUST and GAS					
16A	2,3,4	-40°C ÷ +60°C	T6	T85°C	-
		-40°C ÷ +65°C			85°C
25A		-40°C ÷ +55°C	T5		-
		-40°C ÷ +65°C			90°C
40A		-40°C ÷ +50°C	T6		-
		-40°C ÷ +65°C	T5		95°C
63A		-40°C ÷ +45°C	T6		-
		-40°C ÷ +60°C			95°C

SUITABLE FOR ZONES 2 (GAS) AND 21-22 (DUST)

Isolator switches
in technopolymer
for wall-mounting
50-60Hz
IP66



Rated current (A)	Poles	Enclosure dimensions (mm)	Hole type	Palazzoli code	Pack Qty
16	2	92x125	M25 ↓ □ ↑ M25	292101EX	1
	3	92x125	M25 ↓ □ ↑ M25	292102EX	1
	4	92x125	M25 ↓ □ ↑ M25	292103EX	1
25	2	92x125	M25 ↓ □ ↑ M25	292201EX	1
	3	92x125	M25 ↓ □ ↑ M25	292202EX	1
	4	92x125	M25 ↓ □ ↑ M25	292203EX	1
40	2	125x185	M32 ↓ □ ↑ M32	292301EX	1
	3	125x185	M32 ↓ □ ↑ M32	292302EX	1
	4	125x185	M32 ↓ □ ↑ M32	292303EX	1
63	2	125x185	M32 ↓ □ ↑ M32	292411EX	1
	3	125x185	M32 ↓ □ ↑ M32	292412EX	1
	4	125x185	M32 ↓ □ ↑ M32	292413EX	1

Equipment included: cable gland in technopolymer. Earthing terminal inside the box.

Features: designed for restricted breathing testing.

Notes: the padlockable version is available on request.

CAM-EX Series

Zones 2, 21, 22

ROTARY CONTROL DEVICES
IN ALUMINIUM ALLOY



	GAS			DUST		
ZONE	0	1	2	20	21	22
USABLE			X		X	X

Watertight control devices in aluminium alloy suitable for applications in explosion hazardous areas as defined in ATEX 2014/34/UE Directive. Box and cover are treated with ecological anticorrosion passivation with fluoro-zirconium treatment and finished with hot polymerised, scratch-resistant, non-ageing, non-toxic polyester paint. The cover is attached to the back box by means of stainless steel screws while the sealing is guaranteed by a gasket in non-ageing elastomer. Designed to enable internal and external earthing. The shaft is made of metal, and the switch is of AC23A-AC3 class at rated current with conditional short-circuit current $\geq 10\text{kA}$. Mechanical life of over one million operations.

Rated operating current

			16A	25A	40A	63A
Thermal current Ith		A	16	25	40	63
AC21A	415V	A	16	25	40	63
	500V	A	16	25	40	63
AC22A	415V	A	16	25	40	63
	500V	A	16	25	40	63
AC23A	230V	A	16	25	40	63
	400V					
	500V					
AC23A	230V	kW	4,5	7	11	20
	400V		7,5	12	19	34
	500V		10	14	23	44
AC3	230V	kW	4,5	7	11	18
	400V		7,5	12	19	31
	500V		10	14	23	40

Wiring data:

		16A	25A	40A	63A
Entry cable diameters	mm	12-18		16-25	
Entry cable sections	mm ²	1-4	1,5-6	4-10	6-16
Tightening torque	Nm	1,5		2	

Compliance with standards
ATEX Directive 2014/34/EU
EN 60079-0
EN 60079-15
EN 60079-31

Directive 2014/35/EU
EN 60947-3
EN 60947-1

II 3G 2D

ATEX execution
Ex nR IIC T5/T6 Gc
Ex tb IIIC T 85°C Db
(table on page 33)

Material Aluminium alloy

Surface treatment Passivation with fluoro-zirconium treatment

Paint Hot polymerised non-toxic non-ageing polyester

Colour RAL 9005 (black)

Protection rating (IP according to IEC/EN 60529)
IP66/IP67

Rated current 16A - 25A - 40A - 63A

Operating voltage 500V

Operating frequency 50-60Hz

Conditional short-circuit current isolator switch
 $\geq 10\text{kA}$

Mechanical duration
>1.000.000 operations

Insulation class I

Operating temperature
 $-40^{\circ}\text{C} \div +65^{\circ}\text{C}$
(table on page 33)



Technical data sheets updated to new standards
on palazzoli.com website



TABLE OF AMBIENT TEMPERATURES AND ATEX MARKINGS

In	Poles	Ambient temperature	Temperature class	Maximum surface temperature	Cable temperature	
DUST and GAS						
16A	2,3,4,6	-40°C ÷ +55°C	T6	T85°C	-	
		-40°C ÷ +65°C			90°C	
25A	2,3,4	-40°C ÷ +45°C			T5	-
		-40°C ÷ +65°C				100°C
	6	-40°C ÷ +40°C	-			
		-40°C ÷ +60°C	100°C			
40A	2,3,4	-40°C ÷ +55°C	T6	-		
		-40°C ÷ +65°C		95°C		
	6	-40°C ÷ +50°C		-		
		-40°C ÷ +65°C		95°C		
63A	3,4,6	-40°C ÷ +40°C	-			
		-40°C ÷ +55°C	100°C			



Selector switches
in aluminium alloy
for wall-mounting
50-60Hz
IP66/IP67



Rated current (A)	Poles	Enclosure dimensions (mm)	Entry type	Palazzoli code	Pack Qty
16	3	125x185		272146EX	1
	4	125x185		272147EX	1
25	3	125x185		272246EX	1
	4	125x185		272247EX	1
40	3	125x185		272306EX	1
	4	125x185		272307EX	1
63	3	125x185		282406EX	1
	4	252x185		282407EX*	1

Equipment included: cable gland in technopolymer. Earthing terminal inside and outside the box.
Features: designed for restricted breathing testing.
Notes: *the protection rating is IP65.

SUITABLE FOR ZONES 2 (GAS) AND 21-22 (DUST)



Isolator switches
in aluminium alloy
for wall-mounting
50-60Hz
IP66/IP67



Rated current (A)	Poles	Enclosure dimensions (mm)	Entry type	Palazzoli code	Pack Qty
16	2	92x92		272141EX	1
	3	92x92		272142EX	1
	4	92x92		272143EX	1
	6	125x185		272144EX	1
25	2	92x92		272241EX	1
	3	92x92		272242EX	1
	4	92x92		272243EX	1
	6	125x185		272244EX	1
40	2	125x125		272301EX	1
	3	125x125		272302EX	1
	4	125x125		272303EX	1
	6	125x185		272304EX	1
63	3	125x185		282402EX	1
	4	125x185		282403EX	1
	6	125x185		282404EX	1

Equipment included: cable glands in technopolymer. Earthing terminal inside and outside the box.
Features: designed for restricted breathing testing.
Notes: the padlockable version is available on request.

TAIS MIGNON-EX Series

Zones 2, 22

SMALL CONTROL DEVICES
IN ANTISTATIC THERMOSETTING (GRP)



ZONE	GAS			DUST		
	0	1	2	20	21	22
USABLE			X			X

Small devices and watertight boxes in Palazzoli antistatic thermosetting GRP, suitable for use in explosion hazardous areas as provided for in the ATEX Directive 2014/34/EU.

The cover is attached to the back box by means of stainless steel screws while the sealing is guaranteed by a gasket in non-ageing elastomer.

The degree of protection is IP66 on the whole series.

Compliance with standards
ATEX Directive 2014/34/EU
EN 60079-0
EN 60079-15
EN 60079-31
Directive 2014/35/EU
EN 60669-1
EN 60947-5-1 (Push-buttons)

ATEX execution
Ex II 3G 3D
Ex nR IIC T6 Gc
Ex tc IIIC T 70 °C Dc

Casing material **Palazzoli antistatic thermosetting GRP**

Surface resistance
<10⁹ Ω
(prevention of electrostatic charge accumulation)

Protection rating (IP according to IEC/EN 60529)
IP66

Colour **RAL 9005 (black)**

Resistance to abnormal heat and fire ("Glow wire" according to IEC/EN 60695-2-10)
960°C

Flammability rating (according to UL94)
V0

Operating frequency **50-60Hz**

Insulation class **II**

Entry cable diameter **10 - 14 mm**

Operating temperature **-20°C ÷ +40°C**





Technical data sheets updated to new standards
on palazzoli.com website



SUITABLE FOR ZONES 2 (GAS) AND 22 (DUST)



Isolator switches and two-way switches in thermosetting GRP for wall-mounting **IP66**

Electrical scheme	Poles	Entry type	Rated current/voltage	Palazzoli code	Pack Qty
switch	1P		16A 250V~ / 10A 400V~	202271EX	1
switch	2P		16A 250V~ / 10A 400V~	202282EX	1
two-way switch	1P		16A 250V~ / 10A 400V~	202276EX	1

Equipment included: cable gland in technopolymer type M20.
Features: the lower entry is the predisposition for restricted breathing test.





Selector switch in thermosetting GRP for wall-mounting **IP66**

Poles	Entry type	Rated current/voltage	Palazzoli code	Pack Qty
1P		16A 250V~ / 10A 400V~	202275EX	1

Equipment included: cable gland in technopolymer type M20.
Features: the lower entry is the predisposition for restricted breathing test. By removing the internal jumper, the device can be used as two independent one-pole switches.



Push-buttons in thermosetting GRP for wall-mounting **IP66**

Pole	Entry type	Rated current/voltage	Palazzoli code	Pack Qty
1 NA		10A 400V~	261435EX	1
1 NC		10A 400V~	261445EX	1

Equipment included: cable gland in technopolymer type M20.
Features: the lower entry is the predisposition for restricted breathing test.



Start-stop push button panel in thermosetting GRP for wall-mounting **IP66**

Poles	Entry type	Rated current/voltage	Palazzoli code	Pack Qty
1P		10A 400V~	261432EX	1

Equipment included: cable gland in technopolymer type M20.
Features: the lower entry is the predisposition for restricted breathing test.



On-off push button panel in thermosetting GRP for wall-mounting **IP66**

Poles	Entry type	Rated current/voltage	Palazzoli code	Pack Qty
1P		10A 400V~	261433EX	1

Equipment included: cable gland in technopolymer type M20.
Features: the lower entry is ready for the restricted breathing test.

RONDÒ-EX Series

Zones 2, 22

SMALL CONTROL DEVICES IN ALUMINIUM ALLOY



ZONE	GAS			DUST		
	0	1	2	20	21	22
USABLE			X			X

Small devices and watertight boxes in aluminium alloy suitable for applications in explosion hazardous areas as defined in ATEX Directive 2014/34/EU. Box and cover are treated with ecological anticorrosion passivation with fluoro-zirconium treatment and finished with hot polymerised, scratch-resistant, non-ageing, non-toxic polyester painting. The cover is attached to the back box by means of stainless steel screws while the sealing is guaranteed by a gasket in non-ageing elastomer. Designed to enable internal and external earthing.

Compliance with standards
ATEX Directive 2014/34/EU
EN 60079-0
EN 60079-15
EN 60079-31
Directive 2014/35/EU
EN 60669-1
EN 60947-5-1 (Push-button)

ATEX execution
Ex II 3G 3D
Ex nR IIC T6 Gc
Ex tc IIIC T 70 °C Dc

Material **Aluminium alloy**

Surface treatment **Passivation with fluoro-zirconium**

Paint **Hot polymerised non-toxic non-ageing polyester**

Colour **RAL 9005 (black)**

Protection rating (IP according to IEC/EN 60529) **IP66**

Operating frequency **50 - 60Hz**

Insulation class **I**

Entry cable diameter **10 - 14 mm**

Operating temperature **-20°C ÷ +40°C**



Technical data sheets updated to new standards on palazzoli.com website

SUITABLE FOR ZONES 2 (GAS) AND 22 (DUST)



Switches
in aluminium alloy
for wall-mounting
IP66

Poles	Entry type	Rated current/voltage	Palazzoli code	Pack Qty
1P	M20	16A 250V~ / 10A 400V~	201151EX	1
2P	M20	16A 250V~ / 10A 400V~	201152EX	1

Equipment included: cable gland in technopolymer type M20. Earthing terminal inside and outside the box.
Features: the lower entry is the predisposition for restricted breathing test.



Two-way switch
in aluminium alloy
for wall-mounting
IP66

Poles	Entry type	Rated current/voltage	Palazzoli code	Pack Qty
1P	M20	16A 250V~ / 10A 400V~	201156EX	1

Equipment included: cable gland in technopolymer type M20. Earthing terminal inside and outside the box.
Features: the lower entry is ready for the restricted breathing test.



Push-button
in aluminium alloy
for wall-mounting
IP66

Poles	Entry type	Rated current/voltage	Palazzoli code	Pack Qty
1NA	M20	10A 400V~	261021EX	1

Equipment included: cable gland in technopolymer type M20. Earthing terminal inside and outside the box.
Features: the lower entry is the predisposition for restricted breathing test.

ALARM-EX Series

Zones 2, 21, 22

SIRENS AND BELLS



ZONE	GAS			DUST		
	0	1	2	20	21	22
USABLE			X		X	X

Sirens and bells in aluminium alloy for continuous operation, suitable for applications in explosion hazardous areas as defined in ATEX Directive 2014/34/EU.

The internal terminal block is in self-extinguishing thermosetting GRP insulating material and contributes to the non-sparking protection mode. Earth screws inside and outside the box. Back box and cover are treated with ecological anticorrosion passivation with fluoro-zirconium treatment and finished with hot polymerised scratch-resistant non-toxic polyester painting. The colour of the box is RAL 9005 black while the cover is RAL 2011 deep orange with high recognisability.

The gaskets in non-ageing elastomer and the stainless steel screws guarantee the watertight sealing with IP66 protection rating for the sirens and IP55 for the bells.

Compliance with standards
ATEX Directive 2014/34/EU
EN 60079-0
EN 60079-15
EN 60079-31

Directive 2014/35/EU
EN 62080

Ex II 3G 2D/3D

ATEX execution
(sirens)
II 3G Ex nA IIC T3 Gc
II 2D Ex tb IIIC T 65 °C Db

(bells)
II 3G Ex nA IIC T3 Gc
II 3D Ex tc IIIC T 65 °C Dc

Casing material **Aluminium alloy**

Bell drum material **Painted galvanised steel**

Colour **RAL 9005 (black) - Box**
RAL 2011 (deep orange) - Cover

Protection rating (IP according to IEC/EN 60529)
IP66 (sirens)
IP55 (bells)

Operating voltage **24VAC ÷ 230VAC**

Operating frequency **50-60Hz**

Insulation class **I**

Entry cable diameter **10 - 14 mm**

Operating temperature **-20°C ÷ +40°C**



SUITABLE FOR ZONES 2 (GAS) AND 21-22 (DUST)



Sirens in aluminium alloy
with vibrating membrane
50-60Hz
IP66



Technopolymer
M20 cable gland

Rated voltage (V)	Sound level (dB)	Initial power (VA)	Vibrating power (VA)	Palazzoli code	Pack Qty
24	105	60	25	900453EX	1
110	105	60	25	900463EX	1
230	105	60	25	900473EX	1

Equipment included: cable gland in technopolymer type M20.
Terminal block in insulating thermosetting GRP.
Earthing terminal inside and outside the box.



Directional horn
for sirens

Max. diameter (mm)	Projection siren+horn (mm)	Palazzoli code	Pack Qty
112	238	900449	1

Equipment included: complete with stainless steel fixing screws.

SUITABLE FOR ZONES 2 (GAS) AND 22 (DUST)



Bells in aluminium alloy
with steel drum
50-60Hz
IP55



Technopolymer
M20 cable gland

Rated voltage (V)	Sound level (dB)	Initial power (VA)	Vibrating power (VA)	Palazzoli code	Pack Qty
24	101	13	11	900253EX	1
110	101	13	11	900263EX	1
230	101	13	11	900273EX	1

Equipment included: cable gland in technopolymer type M20.
Terminal block in insulating thermosetting GRP.
Earthing terminal inside and outside the box.

RINO-EX Series

Zones 1, 2, 21, 22

LIGHTING FIXTURES IN STAINLESS STEEL



ZONE	GAS			DUST		
	0	1	2	20	21	22
USABLE		X	X		X	X

Watertight lighting fixtures in stainless steel AISI 304 suitable for applications in areas at risk of explosive atmospheres as defined in ATEX Directive 2014/34/EU.

The diffuser is in tempered glass. The fixing hooks are in stainless steel AISI 304. The sealing is guaranteed by a reinforced gasket in non-ageing elastomer.

Complete with corrosion resistant non-loosening terminals and non-sparking lampholder.

Supplied with M20 cable gland.

Complete with internal and external earth connection.

Compliance with standards

ATEX Directive 2014/34/EU
EN 60079-0
EN 60079-7
EN 60079-18
EN 60079-31
Directive 2014/35/EU
EN 60598-1
EN 60598-2-1
EN 62493
Directive 2014/30/EU
EN 55015
EN 61547
EN 61000-3-2
EN 61000-3-3
Directive 2011/65/EU
EN 50581

Atex execution

Ex II 2G 2D
Ex e mb IIC T4 Gb
Ex tb IIIC T 70 °C Db

Casing material **AISI 304 stainless steel**

Diffuser material **Tempered glass**

Protection rating (IP according to IEC/EN 60529) **IP66**

Operating voltage **110 ÷ 240 Vac-dc**

Operating frequency **0-50-60Hz**

Power factor **≥ 0,9**

Lamp holder **G13 T8 preventing the unhooking**

Max conductor cross-section **4 mm²**

Entry cable diameter **7-12 mm**

Insulation class **I**

Operating temperature **-40°C ÷ +55°C**



Technical data sheets updated to new standards on palazzoli.com website

The photometric curves (LDT files) are available on www.palazzoli.com.



SUITABLE FOR ZONES 1-2 (GAS) AND 21-22 (DUST)



Light fixtures
in stainless steel-glass
with white reflector
IP66



Power (W)	Length (mm)	For tubes type	Version	Photometric curves	Palazzoli code	Pack Qty
1X18	690	T8	standard	8	822181EX	1
1X36	1300			8	822281EX	1
2X18	690			9	822182EX	1
2X36	1300			9	822282EX	1

Features: fluorescent tubes are not included.
Light fixture predisposed with 2+1 M20 holes for in-out connection.
2 M8 threaded holes for fixing the accessories.



Pair of adjustable supports
for wall or ceiling mounting
of steel light fixtures
with screw coupling

Manufacturing material	Rotation angle	Palazzoli code	Pack Qty
AISI 304 stainless steel	± 75°	820010	1

Equipment included: screws and accessories for fixing.



Pair of brackets
for ceiling mounting
of steel light fixtures
with screw coupling

Manufacturing material	Palazzoli code	Pack Qty
AISI 304 stainless steel	820017	1

Equipment included: screws and accessories for fixing.



Pair of eyebolts
for pendant mounting
of steel light fixtures
with screw coupling

Manufacturing material	Palazzoli code	Pack Qty
AISI 304 stainless steel	820011	1

Equipment included: screws and accessories for fixing.



Pair of collars
for mounting on tube
of steel light fixtures
with screw coupling

Manufacturing material	Tube diameter ø (mm)	Palazzoli code	Pack Qty
AISI 304 stainless steel	60	820016	1

Equipment included: screws and accessories for fixing.



Symmetrical reflectors
in aluminium
for steel light fixtures

Manufacturing material	For light fixtures (W)	Palazzoli code	Pack Qty
aluminium	18	820002	1
	36	820003	1

RINO-EX Series

Zones 2, 21, 22

LIGHTING FIXTURES IN STAINLESS STEEL



ZONE	GAS			DUST		
	0	1	2	20	21	22
USABLE			X		X	X

Watertight light fixtures in AISI 304 stainless steel for applications in explosion hazardous areas as defined in ATEX 2014/34/EU Directive. The diffuser is made of tempered glass.

The fixing hooks are in AISI 304 stainless steel. The sealing is guaranteed by a gasket reinforced in non-ageing elastomer.

Complete with corrosion resistant non-loosening terminals and non-sparking lamp holders. Supplied with M20 cable gland.

Complete with internal and external earth connection.

Compliance with standards

Directive ATEX 2014/34/EU
EN 60079-0
EN 60079-15
EN 60079-31
Directive 2014/35/EU
EN 60598-1
EN 60598-2-1
EN 60598-2-22
EN 62493
Directive 2014/30/EU
EN 55015
EN 61547
EN 61000-3-2
EN 61000-3-3
Directive 2011/65/EU
EN 50581

ATEX execution

⊕ II 3G 2D
Ex nA IIC T4 Gc
Ex tb IIIC T 85 °C Db
⊕ II 3G 3D
Ex nR IIC T6 Gc
Ex tc IIIC T 70 °C Dc (emergency)

Casing material **AISI 304 stainless steel**

Diffuser material **Tempered glass**

Protection rating (IP according to IEC/EN 60529) **IP66**

Operating voltage **230 Vac-dc**

Operating frequency **0-50-60Hz**

Power factor **> 0,9**

Lamp holder **G13 T8**

Max conductor cross-section **2,5 mm²**

Entry cable diameter **10 - 14 mm**

Emergency battery lifetime **1h**

Emergency battery recharging time **24h**

Insulation class **I**

Operating temperature **-20°C ÷ +40°C (2 tubes)**
-20°C ÷ +50°C (1 tube)



Technical data sheets updated to new standards on palazzoli.com website

The photometric curves (LDT files) are available on www.palazzoli.com.



SUITABLE FOR ZONES 2 (GAS) AND 21-22 (DUST)



Light fixtures
in stainless **steel-glass**
with **white reflector**
IP66

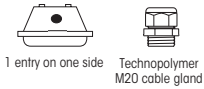

Power (W)	Length (mm)	For tubes type	Version	Photometric curves	Palazzoli code	Pack Qty
1X18	690	T8	standard	8	822131EX	1
1X36	1300			8	822231EX	1
1X58	1600			8	822331EX	1
2X18	690			9	822132EX	1
2X36	1300			9	822232EX	1
2X58	1600			9	822332EX	1
(1+1)x18	690	T8	emergency	9	822111EX	1
(1+1)x36	1300			9	822211EX	1
(1+1)x58	1600			9	822311EX	1

Equipment included: pair of hooks in AISI 304 steel for pendant mounting, code 820001.

Features: fluorescent tubes are not included.

Notes: emergency light fixtures are suitable for zone 2-22.



Light fixtures
in stainless **steel - glass**
with **symmetrical**
aluminium reflector
IP66

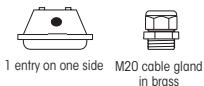

Power (W)	Length (mm)	For tubes type	Version	Photometric curves	Palazzoli code	Pack Qty
1X18	690	T8	standard	10	820131EX	1
1X36	1300			10	820231EX	1
1X58	1600			10	820331EX	1
2X18	690			11	820132EX	1
2X36	1300			11	820232EX	1
2X58	1600			11	820332EX	1
(1+1)x18	690	T8	emergency	11	820111EX	1
(1+1)x36	1300			11	820211EX	1
(1+1)x58	1600			11	820311EX	1

Equipment included: pair of hooks in AISI 304 steel for pendant mounting, code 820001.

Features: fluorescent tubes are not included.

Notes: emergency light fixtures are suitable for zone 2-22.



Pair of hooks
for **suspended** installations
of steel light fixtures

Manufacturing material	Palazzoli code	Pack Qty
AISI 304 stainless steel	820001	1



Pair of adjustable supports
for **wall and ceiling**
installations of steel light
fixtures

Manufacturing material	Rotation angle	Palazzoli code	Pack Qty
AISI 304 stainless steel	± 75°	820000	1



Pair of collars
for mounting
steel light fixtures on **tube**

Manufacturing material	Tube diameter Ø (mm)	Palazzoli code	Pack Qty
AISI 304 stainless steel	60	820006	1

RINO-EX Series

Zones 2, 21, 22

LIGHTING FIXTURES IN STAINLESS STEEL



ZONE	GAS			DUST		
	0	1	2	20	21	22
USABLE			X		X	X

Watertight light fixtures in aluminium alloy suitable for applications in explosion hazardous areas as defined in ATEX Directive 2014/34/EU.

The body of the light fixture is treated with ecological anti-corrosion passivation with fluoro-zirconium and finished with hot polymerised scratch-resistant non-toxic non-ageing polyester painting. The colour of the body is light grey RAL 7035. The diffuser is in prismatic tempered glass. The steel wire protection cage is RAL 2011 deep orange and is attached to the body by means of stainless steel screws while the sealing is guaranteed by a reinforced gasket in non-ageing elastomer. Predisposed for entry through an M20 cable gland. Complete with internal and external earth screw.

Compliance with standards	Directive ATEX 2014/34/EU EN 60079-0 EN 60079-15 EN 60079-31 Directive 2014/35/EU EN 60598-1 EN 60598-2-1 Directive 2011/65/EU EN 50581
ATEX execution	⊕ II 3G 2D Ex nA IIC T3 Gc Ex tb IIIC T 75/85/90 °C Db
Casing material	Aluminium alloy
Surface treatment	Passivation with fluoro-zirconium treatment
Paint	Hot polymerised non-toxic, non-ageing polyester
Colour	RAL 7035 (light grey) Back box RAL 2011 (deep orange) Protection cage
Diffuser material	Prismatic tempered glass
Protection rating (IP according to IEC/EN 60529)	IP65
Protective cage material	Painted tropicalized steel wire
Supply voltage	230V
Operating frequency	50-60Hz
Max conductor cross-section	2.5 mm ²
Entry cable diameter	10 - 14 mm
Lamp holder type	E27 in porcelain
Insulation class	I
Operating temperature	-20°C ÷ +40°C



Technical data sheets updated to new standards on palazzoli.com website

SUITABLE FOR ZONES 2 (GAS) AND 21-22 (DUST)



Oval light fixtures
in aluminium alloy
with steel protective cage
IP65

Power (W)	Dimensions (mm)	Palazzoli code	Pack Qty
18	199x112	831072EX	1
28	226x130	831172EX	1
53	295x170	831272EX	1

Equipment included: internal and external earth screw and cable gland.



Round light fixtures
in aluminium alloy
with steel protective cage
IP65

Power (W)	Dimensions (mm)	Palazzoli code	Pack Qty
28	200x182	830072EX	1

Equipment included: internal and external earth screw and cable gland.

Light fixture/lamp selection

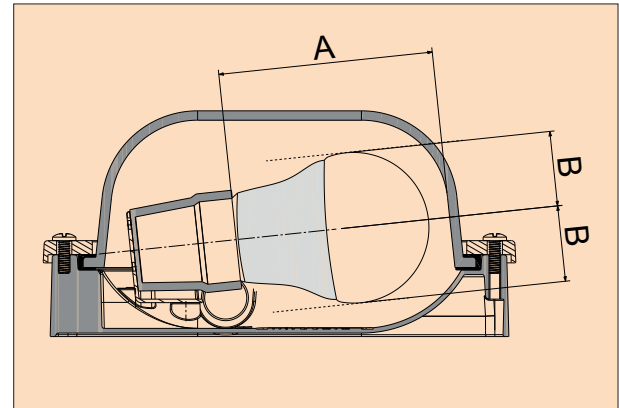

Dimensions

Type bulb	Power halogen lamps* (W)	A (mm)	B (mm)
	18	90	38
	28	110	40
	53	168	43
	28	90	38

*The certification is valid only with the use of halogen lamps.

RINO-EX Series

Zones 2, 22

LED LIGHTING FIXTURES IN STAINLESS STEEL

50.000h



ZONE	GAS			DUST		
	0	1	2	20	21	22
USABLE			X			X

Watertight light fixtures in AISI 2014/34 stainless steel for applications in explosion hazardous areas as defined in ATEX Directive 304/EU.

The light fixture is equipped with LED strips, 4000K colour temperature and CRI \geq 80, installed on an ultra-bright aluminium reflector.

The body is cold-drawn in a single piece. The diffuser is in tempered glass without metallic frame. The IP66 rating is guaranteed by a reinforced gasket in non-ageing elastomer and hooks in stainless steel AISI304.

The cable entry is made with an M20 cable gland in technopolymer.

Compliance with standards

Directive ATEX 2014/34/EU
EN60079-0
EN60079-15
EN60079-31
Directive 2014/35/EU
EN 60598-1
EN 60598-2-1
EN 62471
EN 60598-2-22
EN 62493
IEC/TR 62778
Directive 2014/30/EU
EN 55015
EN 61547
EN 61000-3-2
EN 61000-3-3
Directive 2011/65/EU
EN 50581

ATEX execution

Ex II 3G 3D
Ex nR IIC T6 Gc
Ex tc IIIC T 70 °C Dc

Body material

AISI 304 stainless steel
Painted galvanised steel

Diffuser material

Tempered glass

Protection rating (IP according to IEC/EN 60529)

IP66

Paint

Non-toxic polyester resistant to weather conditions and UV rays

Colour

RAL 9016 (painted galvanised steel version)

Impact resistance (IK rating according to IEC/EN 62262)

IK09

Colour temperature

4000K

CRI

\geq 80

Insulation class

I

Supply voltage

230 - 240V

Operating frequency

50-60Hz

Input surge protection EN 61000

2 kV

Photobiological risk

Exempt

Power factor

\geq 0,95

Max conductor cross-section

2,5 mm²

Entry cable diameter

10 -14 mm

Emergency battery lifetime

1h (3h on request)

Emergency battery recharging time

24h

Estimated device lifetime

L80 B20 @50.000h Tq=25°C

Storage temperature

-40°C - +70°C

Operating temperature

-25°C - +40°C



The photometric curves (LDT files) are available on www.palazzoli.com.

Technical data sheets updated to new standards on palazzoli.com website



SUITABLE FOR ZONES 2 (GAS) AND 22 (DUST)

50.000h



LED light fixtures in **stainless steel - glass** with **extra wide beam optics IP66**

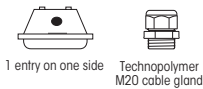

Device power (W)	Length (mm)	Rated flux (lm) Tj= 25 °C	Output flux (lm) Tq= 25 °C	Version	Photometric curves	Palazzoli code	Pack Qty
24	690	3300	2885	standard	20	822142EX	1
38	1300	5600	4982		21	822242EX	1
44	1600	6500	6043		24	822342EX	1
19	690	2750	2468	emergency	22	822140EX	1
36	1300	5250	4756		23	822240EX	1
44	1600	6500	6043		24	822340EX	1

Equipment included: pair of hooks in AISI 304 steel for pendant mounting, code 820001.

Notes: the stated values may be subject to a +/- 7% tolerance.

50.000h



LED light fixtures in **painting galvanised steel-glass** with **extra wide beam optics IP66**

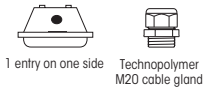

Device power (W)	Length (mm)	Rated flux (lm) Tj= 25 °C	Output flux (lm) Tq= 25 °C	Version	Photometric curves	Palazzoli code	Pack Qty
24	690	3300	2885	standard	20	842142EX	1
38	1300	5600	4982		21	842242EX	1
19	690	2750	2468		22	842140EX	1
36	1300	5250	4756	emergency	23	842240EX	1

Equipment included: pair of hooks in AISI 304 steel for pendant mounting, code 820001.

Notes: the stated values may be subject to a +/- 7% tolerance.

EMERGENCY FLUX		
Rated flux (lm) Tj= 25 °C	Output flux (lm) Tq= 25 °C	Output flux in emergency (lm) Tq= 25 °C
2.750	2.468	691
5.250	4.756	760
6.500	6.043	728

Notes: the emergency flux is achieved by reducing the rated flux of the unit.



Pair of **hooks** for **suspended** installations of steel light fixtures

Manufacturing material	Palazzoli code	Pack Qty
AISI 304 stainless steel	820001	1



Pair of **adjustable supports** for **wall** and **ceiling** installations of steel light fixtures

Manufacturing material	Rotation angle	Palazzoli code	Pack Qty
AISI 304 stainless steel	± 75°	820000	1



Pair of **collars** for mounting steel light fixtures on **tube**

Manufacturing material	Tube diameter ø (mm)	Palazzoli code	Pack Qty
AISI 304 stainless steel	60	820006	1

META-EX Series

Zone 22

HIGH-BAY LED LIGHTING FIXTURES IN ALUMINIUM ALLOY

110.000h

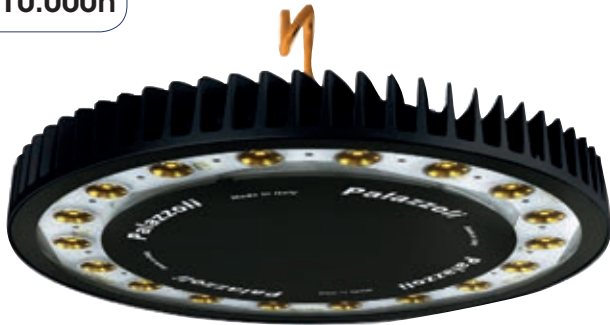

ZONE	GAS			DUST		
	0	1	2	20	21	22
USABLE						X

META-EX is suitable for use in explosion hazardous areas according to ATEX directive 2014/34/EU. META-EX guarantees specific lighting and mechanical characteristics for installation in industrial environments, food industries and outdoor areas. The body is made of die-cast aluminium with anti-corrosion treatment, finished with a scratch-resistant powder coating. The diffuser, made of 4 mm extra-clear tempered glass, guarantees maximum resistance in harsh environments with chemical substances. Thanks to the different optics available in the catalogue (extra wide beam, narrow beam, elliptical beam and asymmetrical beam), the working areas can be illuminated in the best possible way, guaranteeing visual comfort and the best lighting performance.

Technical data sheets updated to new standards on palazzoli.com website

Compliance with standards
Directive ATEX 2014/34/EU
EN 60079-0
EN 60079-31
Directive 2014/35/EU
EN 60598-1
EN 60598-2-1
EN 62471
EN 62493
IEC/TR 62778
Directive 2014/30/EU
EN 55015
EN 61547
EN 61000-3-2
EN 61000-3-3
Directive 2011/65/EU
EN 50581

ATEX execution	II 3D
Body material	Aluminium alloy
Surface treatment	Fluoro-zirconium treatment
Diffuser material	Extra clear tempered glass
Protection rating (IP according to IEC/EN 60529)	IP66/IP67
Paint	Hot-polymerised non-toxic polyester
Colour	RAL 9005
Impact resistance (IK rating according to IEC/EN 62262)	IK08
Corrosion class	C3 according to ISO 9223
Weight	9,5 Kg max
LED device efficiency	106 lm/W
Colour temperature	4000 K
CRI	≥ 80
Insulation class	I
Supply voltage	200-240 V
Operating frequency	50-60 Hz
Input surge protection EN 61000	10kV common mode 6 kV differential mode
Residual flicker	< 1%
Photobiological risk	Exempt
Glare index	UGR ≤ 22
Power factor	≥ 0,95
Max conductor cross-section	1,5 mm ²
Entry cable diameter	7-13 mm
Entry cable	ATEX cable gland M20
Estimated device lifetime	L80 B20 @110.000h Tq= -30 °C to +40 °C
Storage temperature	-40 °C - +70 °C
Operating temperature	-30 °C to + 40 °C (up to +55 °C or other special configurations on request).



The photometric curves (LDT files) are available on www.palazzoli.com.



SUITABLE FOR ZONE 22 (DUST)

110.000h



Suspension LED light fixtures
glass diffuser
roto-symmetrical
extra wide beam optics
IP66/IP67

Device power (W)	Rated flux (lm) Tj= 25 °C	Output flux (lm) Tq= 25 °C	Version	Photometric curves	Palazzoli code	Pack Qty
99	13230	10830	1-10 V dimmable standard	16	810090EX	1
133	17640	14439		16	810020EX	1
168	22050	18049		16	810050EX	1
199	26460	21659		16	810080EX	1

Equipment included: support for rapid pendant suspension.
Characteristics: typical height of installation between 5 and 9 meters.
Technical accessories: junction boxes in aluminium at page 21.
Note: the stated values may be subject to a +/- 7% tolerance. Other DALI or wireless control systems are available on request.

110.000h

UGR≤22



Suspension LED light fixtures
glass diffuser
roto-symmetrical
narrow beam optics
IP66/IP67

Device power (W)	Rated flux (lm) Tj= 25 °C	Output flux (lm) Tq= 25 °C	Version	Photometric curves	Palazzoli code	Pack Qty
99	13230	10572	1-10 V dimmable standard	17	810091EX	1
133	17640	14096		17	810021EX	1
168	22050	17620		17	810051EX	1
199	26460	21144		17	810081EX	1

Equipment included: quick connection for suspension.
Features: typical installation height over 9 m.
Technical accessories: junction boxes in aluminium at page 21.
Notes: the stated values may be subject to a +/- 7% tolerance. Other DALI or wireless control systems are available on request.

110.000h

UGR≤22



Suspension LED light fixtures
glass diffuser
elliptical beam optics
IP66/IP67

Device power (W)	Rated flux (lm) Tj= 25 °C	Output flux (lm) Tq= 25 °C	Version	Photometric curves	Palazzoli code	Pack Qty
99	13230	9965	1-10 V dimmable standard	18	810092EX	1
133	17640	13287		18	810022EX	1
168	22050	16609		18	810052EX	1
199	26460	19931		18	810082EX	1

Equipment included: connection with double chain bracket.
Features: suitable for installation between the aisles of industrial warehouses etc.
Technical accessories: junction boxes in aluminium at page 21.
Notes: the stated values may be subject to a +/- 7% tolerance. Other DALI or wireless control systems are available on request.

110.000h

UGR≤22

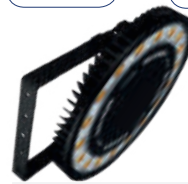

LED floodlights
glass diffuser
asymmetrical optics
IP66/IP67

Device power (W)	Rated flux (lm) Tj= 25 °C	Output flux (lm) Tq= 25 °C	Version	Photometric curves	Palazzoli code	Pack Qty
99	13230	9193	1-10 V dimmable standard	19	810296EX	1
133	17640	12258		19	810226EX	1
168	22050	15322		19	810256EX	1
199	26460	18387		19	810286EX	1

Equipment included: adjustable bracket for wall-mounting or mounting on load-bearing structures (walls, poles, pylons).
Features: suitable for illuminating outdoor areas.
Technical accessories: junction boxes in aluminium at page 21.
Notes: the stated values may be subject to a +/- 7% tolerance. Other DALI or wireless control systems are available on request.



Pair of brackets
 for mounting on
 double chain and busbar

Manufacturing material	Palazzoli code	Pack Qty
galvanised steel	810997	1



0 - 90° adjustable bracket
 for mounting on double chain

Manufacturing material	Palazzoli code	Pack Qty
galvanised steel	810996	1

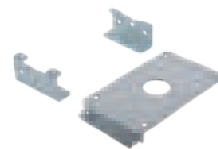

Kit with bracket
 for ceiling mounting

Manufacturing material	Palazzoli code	Pack Qty
galvanised steel	810998	1



0 - 90° adjustable bracket
 for mounting
 on catenary cable

Manufacturing material	Palazzoli code	Pack Qty
galvanised steel	810994	1

Dimensions

TAIS-EX Series

Sockets

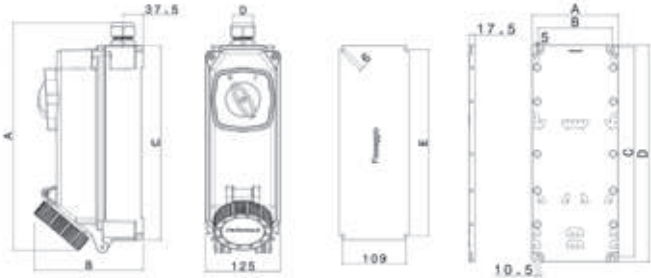

ALUPRES-EX Series

Sockets

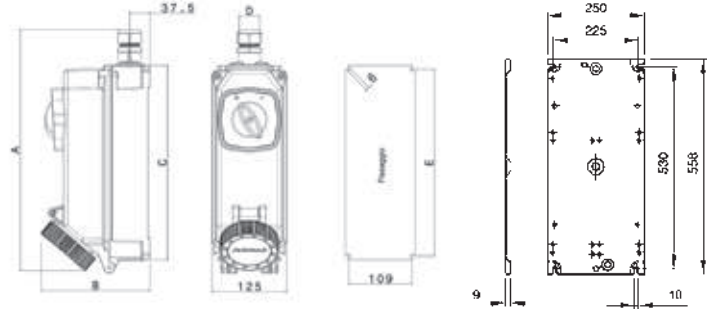

Rated current (A)	Poles	Ø entry cable (mm)	A (mm)	B (mm)	C (mm)	D (mm)	E (mm)
16	2P++	12÷18	380	159	335	M25	319
	3P++			164			
	3P+N++			175			
20 / 32	2P++	16÷25	380	177	335	M32	319
	3P++			185			
	3P+N++			185			
40 / 63	2P++	16÷25	423	203	370	M32 / M40	354
	3P++						
	3P+N++						

Code	A (mm)	B (mm)	C (mm)	D (mm)
532800	125	110		
532802	250	215	609	630
532804	380	345		

Rated current (A)	Poles	Ø entry cable (mm)	A (mm)	B (mm)	C (mm)	D (mm)	E (mm)
16	2P++	12÷18	350	150	315	M25	300
	3P++			155			
	3P+N++			160			
25 / 32	2P++	16÷25	390	168	315	M32	300
	3P++			170			
	3P+N++			170			
40 / 63	2P++	16÷25	430	188	355	M32	340
	3P++						
	3P+N++						

TAIS-EX Series

Boxes

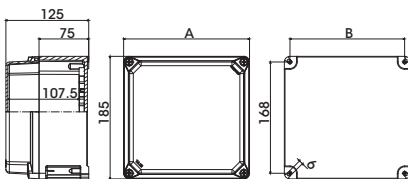

Code	A (mm)	B (mm)
532200EX - 532240EX	125	108
532201EX	190	173
532202EX - 532242EX	250	233
532203EX	290	273
532204EX - 532244EX	380	363

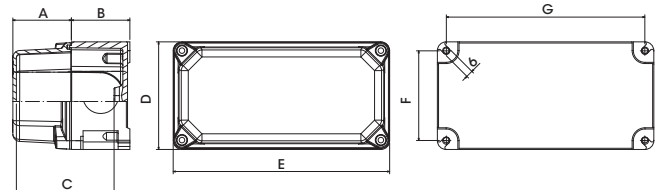

Code	A (mm)	B (mm)	C (mm)	D (mm)	E (mm)	F (mm)	G (mm)
532035EX	18	50	51	92	92	78	78
532045EX	18	50	51	92	125	78	111
532055EX	18	50	51	92	185	78	171
532116EX	18	75	75	125	125	111	111
532117EX	18	75	75	125	185	111	171
532118EX	18	75	75	125	250	111	238
532005EX	50	50	83	92	92	78	78
532006EX	50	50	83	92	125	78	111
532015EX	50	50	83	92	185	78	171
532016EX	50	75	100	125	125	111	111
532017EX	50	75	100	125	185	111	171
532018EX	50	75	100	125	250	111	238

ALUPRES-EX Series

Boxes

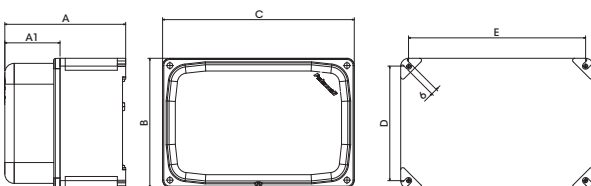

Code	A (mm)	A1 (mm)	B (mm)	C (mm)	D (mm)	E (mm)
150021EX	73	10	155	155	141	141
511910EX	77	35	92	92	78	78
511911EX	92	50	92	125	78	111
511912EX	92	50	92	185	78	171
511913EX	113	50	125	125	111	111
511917EX	113	50	125	252	111	238
511920EX	145	50	185	185	171	171
511921EX	145	57	185	252	169	236
511922EX	108	13	220	220	192	205
511923EX	197	57	252	252	224	237

CAM-EX Series in thermosetting

CAM-EX Series in aluminium alloy

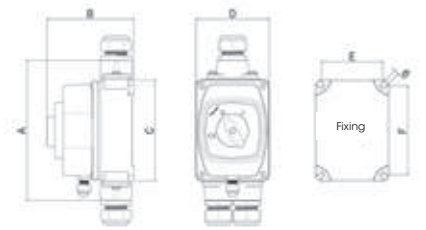
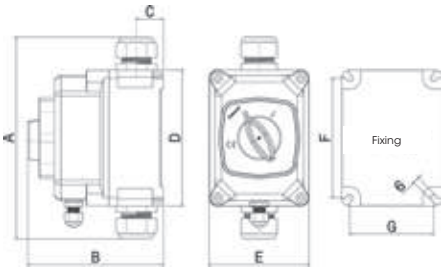

Rated current (A)	Ø entry cable (mm)	A (mm)	B (mm)	C (mm)	D (mm)	E (mm)	F (mm)	G (mm)
10-16	10÷14	175	122	25	125	92	111	78
20-25	12÷18							
32-40								
50-63	16÷25	260	165	37,5	185	125	169	109

Rated current (A)	Ø entry cable (mm)	A (mm)	B (mm)	C (mm)	D (mm)	E (mm)	F (mm)	
272141EX	12÷18	137,5	102	92	92	77	77	
272142EX								
272143EX								
272144EX								
272241EX		-	148	185	125	110	170	
272242EX								
272243EX		16÷25	-	148	185	125	110	170
272244EX								
272301EX			232	137	125	125	110	110
272302EX								
272303EX								
272304EX								
282402EX	-	148	185	125	110	170		
282403EX								
282404EX								

Code	Ø entry cable (mm)	Ø exit cable (mm)	A (mm)	B (mm)	C (mm)	D (mm)	E (mm)	F (mm)
272146EX	12÷18	-	148	185	125	110	170	
272147EX								
272246EX								
272247EX								
272306EX	16÷25	-	148	185	125	110	170	
272307EX								
282406EX			-					168
282407EX								

XCEE-EX Series

ALARM-EX Series

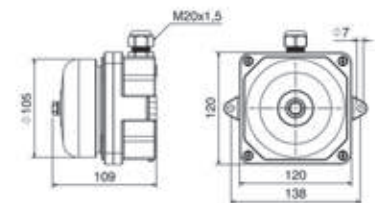
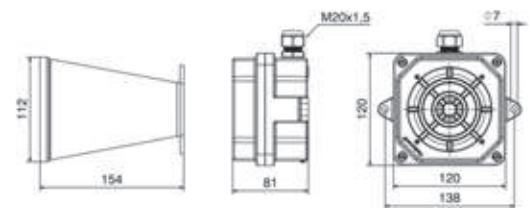
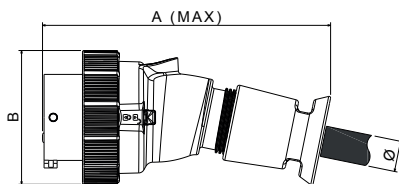

Rated current (A)	Poles	A (mm)	B (mm)	Ø (mm)
16	2P+≎	167	72	6.3÷18
	3P+≎	173.5	80	
	3P+N+≎	186.5	87	
32	2P+≎	194	93	11÷23
	3P+≎			
	3P+N+≎			13÷27
63	2P+≎	252	112	14.5÷37
	3P+≎			
	3P+N+≎			

TAIS MIGNON-EX Series

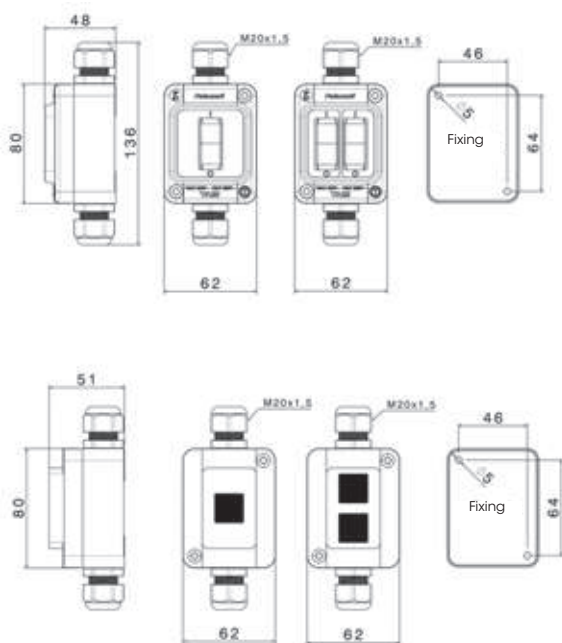

RONDÒ-EX Series

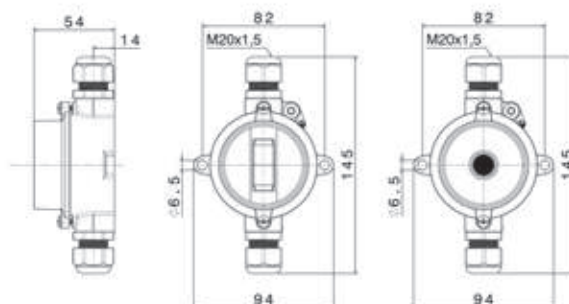

RINO-EX Series

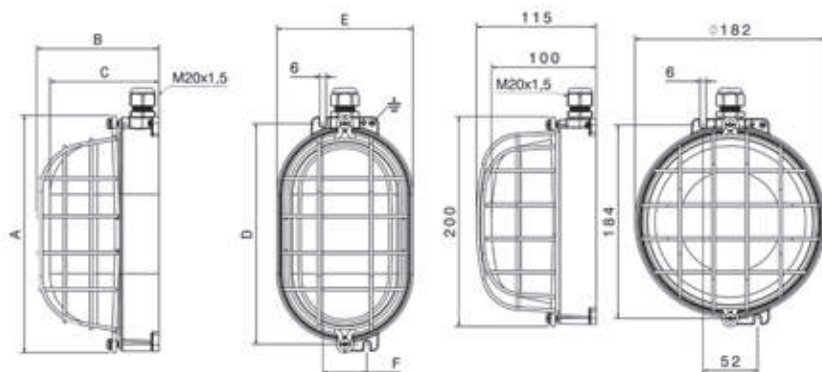

Power (W)	A (mm)	B (mm)	C (mm)	D (mm)	E (mm)	F (mm)
18	199	119	100	184	112	42
28	226	122	105	210	130	42
53	295	142	127	278	170	52

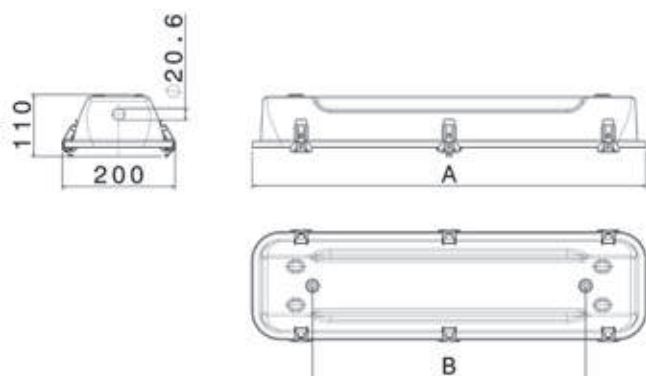

Fluorescent lamp type	A (mm)	B (mm)
18WT8	690	480
36WT8	1300	1090
58WT8	1600	1395

LED type	A (mm)	B (mm)
19W - 24W	690	480
36W - 38W	1300	1090
44W	1600	1395

META-EX Series

Pendant suspension

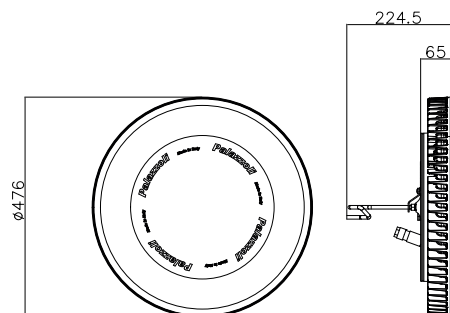

Double chain suspension

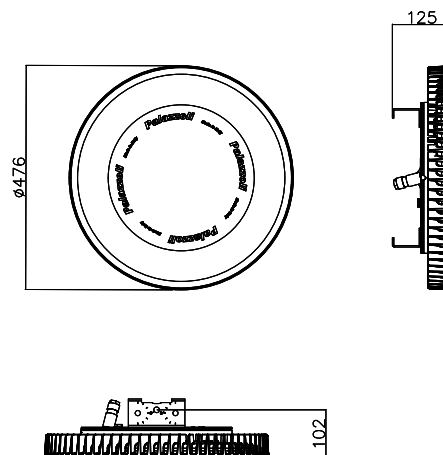

Adjustable double chain suspension

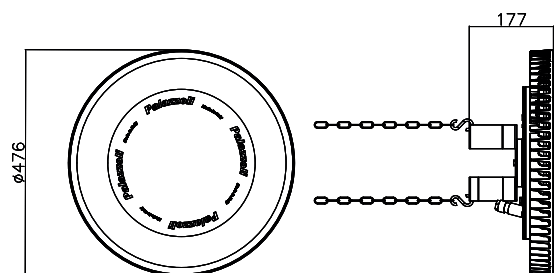

Ceiling mounting

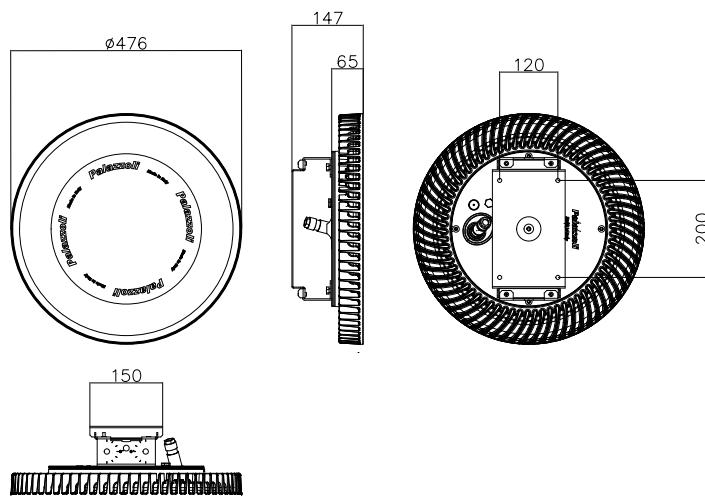

Wall mounting with bracket

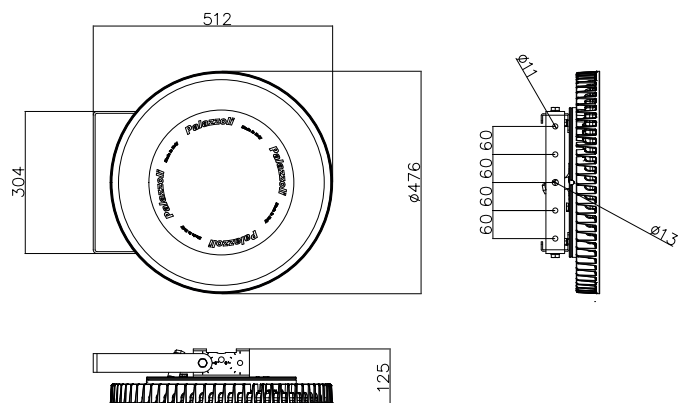

Catenary wire suspension

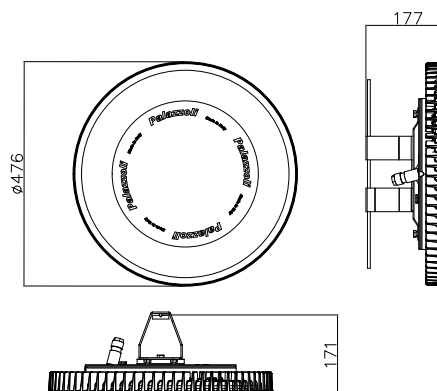

Made in an accredited laboratory conforming to UNI EN 13032-1-4 and IES LM 79-08 Standards

MITO Led ATEX

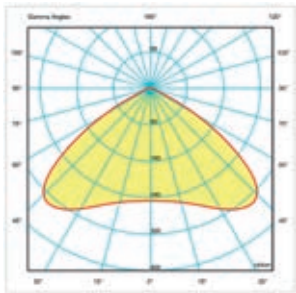

16 - Symmetrical light distribution, extra wide beam

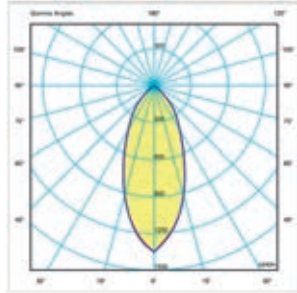

17 - Symmetrical light distribution, narrow beam

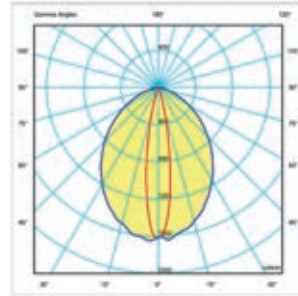

18 - Elliptical light distribution

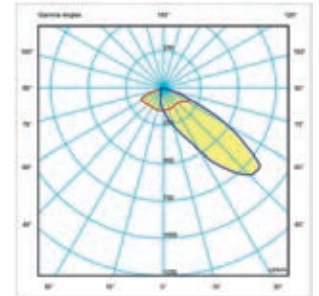

19 - Asymmetrical light distribution

LED ATEX

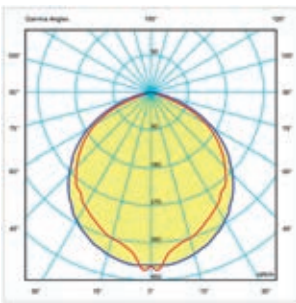

20 - Extra wide beam - 24W

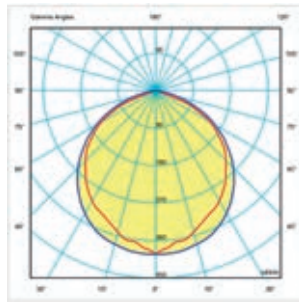

21 - Extra wide beam - 38W

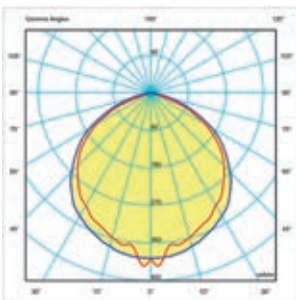

22 - Extra wide beam - 19W

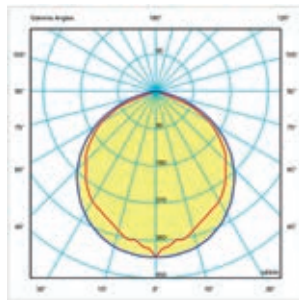

23 - Extra wide beam - 36W

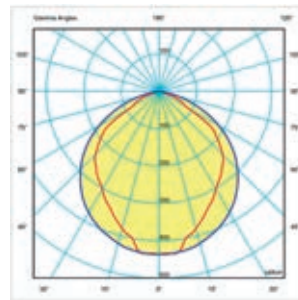

24 - Extra wide beam - 44W

ATEX FLUORESCENT

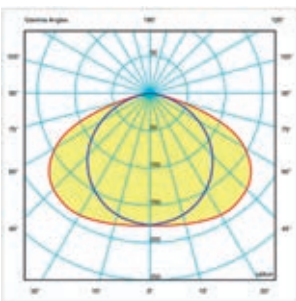

8 - T8 - 1 tube - White reflector

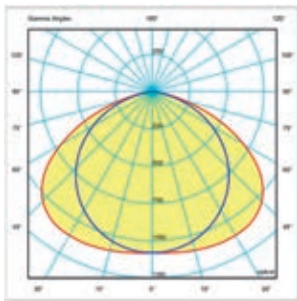

9 - T8 - 2 tubes - White reflector

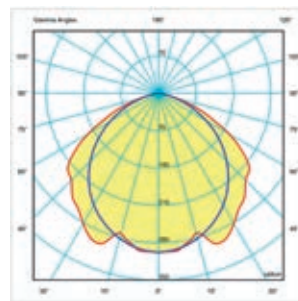

10 - T8 - 1 tube - Symmetrical

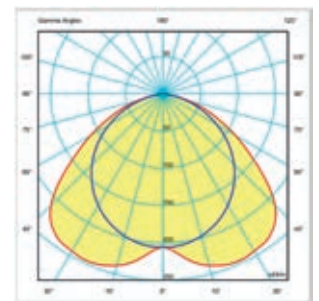

11 - T8 - 2 tubes - Symmetrical

Palazzoli Academy

ELECTRICAL INSTALLATIONS IN ATEX



INTRODUCTION	page	57
Chap.1 THE HISTORY	page	58
1.1 - HISTORICAL FACTS AND CURIOSITIES	page	58
Chap.2 TECHNICAL ASPECTS	page	60
2.1 EXPLOSION	page	60
2.2 EXPLOSIVE ATMOSPHERE FROM GAS	page	61
2.2.1 Limits of inflammability	page	61
2.2.2 Minimum ignition energy	page	61
2.2.3 Flash point	page	62
2.2.4 Autoignition temperature	page	63
2.2.5 Gas classification in ATEX according to IEC/EN 60079 standards	page	63
2.3 EXPLOSIVE ATMOSPHERE FROM DUST	page	64
2.3.1 Explosibility limits	page	65
2.3.2 Minimum ignition energy	page	65
2.3.3 Ignition temperature and glowing temperature	page	65
2.3.4 Electrical resistivity	page	66
2.3.5 Dust classification in ATEX according to IEC/EN 60079 standards	page	66
2.4 ELECTRICAL IGNITION SOURCES	page	66
2.4.1 Electric arc	page	67
2.4.2 Surface temperature	page	67
2.4.3 Electrostatic discharge	page	67
Chap.3 ZONES AND PROTECTION LEVELS	page	69
3.1 SOURCES OF RELEASE AND ZONE CLASSIFICATION	page	69
3.2 EQUIPMENT PROTECTION LEVEL-EPL	page	72
Chap.4 TYPES OF PROTECTION	page	74
4.1 TYPES OF PROTECTION	page	74
4.1.1 Flameproof enclosures Ex-d	page	76
4.1.2 Increased safety Ex-e	page	76
4.1.3 Intrinsic safety Ex-i	page	77
4.1.4 Encapsulation Ex-m	page	78
4.1.5 Type of protection nA-nC-nR	page	79
4.1.6 Oil immersion Ex-o	page	81
4.1.7 Powder filling Ex-q	page	81
4.1.8 Pressurized enclosure Ex-p	page	82
4.1.9 Protection by enclosures Ex-t	page	82
4.1.10 Protection by "combined" types of protection	page	83
Chap.5 REQUIREMENTS FOR EX DEVICES	page	84
5.1 CLASSIFICATION OF ELECTRICAL EQUIPMENT FOR GAS ACCORDING TO IEC/EN 60079-0	page	84
5.2 CLASSIFICATION OF ELECTRICAL EQUIPMENT FOR DUST ACCORDING TO IEC/EN 60079-0	page	86
5.3 GENERAL REQUIREMENTS FOR ELECTRICAL EQUIPMENT	page	86
5.3.1 Thermal and impact resistance and IP rating	page	87
5.3.2 Gasket sealing	page	89
5.3.3 Resistance to light	page	89
5.3.4 Electrostatic charges	page	90
5.3.5 Characteristics of plastic and elastomeric materials	page	92
Chap.6 ATEX DIRECTIVES AND EX PRODUCT MARKING	page	93
6.1 DIRECTIVE 99/92/EC	page	93
6.2 DIRECTIVE 2014/34/EU	page	94
6.2.1 Equipment groups and categories	page	95
6.3 2014/34/EU DIRECTIVE AND DIFFERENCES WITH 94/9/EC	page	97
6.4 EX PRODUCT MARKING	page	99
6.4.1 CE marking	page	99
6.4.2 Marking according to the ATEX directive	page	100
Cap.7 CERTIFICATIONS	page	105
7.1 CONFORMITY ASSESSMENT	page	105
7.2 THE TECHNICAL DOCUMENTATION	page	106
7.2.1 Safety instructions, use and maintenance	page	107
7.2.2 Ignition risk analysis document	page	108
7.2.3 EU declaration of conformity	page	108
7.2.4 EU-type-examination certificate	page	110

Chap.8 ATEX vs IECEx	page	112
8.1 THE IECEx SCHEME	page	112
8.2 DIFFERENCES BETWEEN ATEX DIRECTIVES AND IECEx SCHEME	page	112
8.3 IECEx MARKING	page	115
8.4 WORLD MAP WITH ATEX-IECEx-OTHER SCHEMES	page	116
Chap.9 AREA CLASSIFICATION	page	117
9.1 INTRODUCTION	page	117
9.2 HAZARDOUS AREA CLASSIFICATION PROCEDURE	page	117
9.2.1 Procedures to classify hazardous areas	page	118
9.3 DEFINITIONS AND INFORMATION	page	118
9.3.1 Explosive atmosphere	page	118
9.3.2 Source of release	page	118
9.3.3 Grade of release	page	119
9.3.4 Dusts – levels of housekeeping	page	119
9.3.5 Zones	page	119
9.4 GARAGES	page	120
9.4.1 Locate the environment	page	120
9.4.2 Flammable substance	page	121
9.4.3 Sources of release	page	121
9.4.4 Grades of release	page	122
9.4.5 Load of release	page	122
9.4.6 Type of zone	page	122
9.4.7 Hazardous distance	page	123
9.4.8 Hazardous area classification	page	123
9.5 CAR REPAIR SHOPS	page	124
9.5.1 Locate the environment	page	124
9.5.2 Flammable substances	page	124
9.5.3 Sources of release	page	125
9.5.4 Grades of release	page	125
9.5.5 Load of release	page	125
9.5.6 Type of zone	page	125
9.5.7 Hazardous distance	page	126
9.5.8 Hazardous area classification	page	126
9.6 NATURAL GAS THERMAL PLANTS	page	127
9.6.1 Locate the environment	page	127
9.6.2 Flammable substances	page	127
9.6.3 Sources of release	page	128
9.6.4 Grade of release	page	128
9.6.5 Load of release	page	128
9.6.6 Type of zone	page	128
9.6.7 Hazardous distance	page	129
9.6.8 Hazardous area classification	page	129
9.7 CARPENTRIES	page	130
9.7.1 Locate the environment	page	130
9.7.2 Flammable substances	page	130
9.7.3 Sources of release	page	131
9.7.4 Grade of release	page	132
9.7.5 Load of release	page	132
9.7.6 Type of zone	page	132
9.7.7 Hazardous distance	page	133
9.7.8 Hazardous area classification	page	133
9.8 AGRICULTURAL INDUSTRIES	page	134
9.8.1 Locate the environment	page	134
9.8.2 Flammable substances	page	134
9.8.3 Sources of release	page	135
9.8.4 Grade of release	page	135
9.8.5 Load of release	page	135
9.8.6 Type of zone	page	135
9.8.7 Hazardous distance	page	137
9.8.8 Hazardous area classification	page	137
Chap.10 INSTALLATION METHODS	page	138
10.1 GENERALITIES	page	138
10.2 TERMS AND DEFINITIONS	page	139
10.3 BRIEF GENERAL INFORMATION	page	139
10.3.1 Overload	page	139

10.3.2	Short-circuit	page	140
10.3.3	Electric arc	page	141
10.3.4	Dangerous sparks	page	141
10.3.5	Static electricity	page	141
10.3.6	Thermal effects	page	142
10.4	GARAGES	page	142
10.4.1	Generalities	page	142
10.4.2	Explosion	page	142
10.4.3	Fire	page	143
10.4.4	External influences	page	143
10.4.5	Selection and installation of electrical components	page	143
10.5	CAR REPAIR SHOPS	page	144
10.5.1	Generalities	page	144
10.5.2	Explosion	page	145
10.5.3	Fire	page	145
10.5.4	External influences	page	145
10.5.5	Selection and installation of electrical components	page	145
10.6	THERMAL PLANTS	page	149
10.6.1	Generalities	page	149
10.6.2	Explosion	page	149
10.6.3	Fire	page	150
10.6.4	External influences	page	150
10.6.5	Selection and installation of electrical components	page	150
10.7	CARPENTRIES	page	151
10.7.1	Explosion	page	151
10.7.2	Fire and external influences	page	152
10.7.3	Selection and installation of electrical components	page	152
10.8	AGRICULTURAL INDUSTRIES	page	154
10.8.1	Generalities	page	154
10.8.2	Explosion	page	154
10.8.3	Fire	page	154
10.8.4	External influences	page	155
10.8.5	Selection and installation of electrical components	page	155
Chap.11	PROCEDURE FOR TEMPORARY TESTS	page	157
11.1	GENERALITIES	page	157
11.2	INSPECTION AND MAINTENANCE	page	157
11.3	INSULATION	page	158
11.4	EQUIPMENT WITHOUT MARKING	page	158
11.5	DOCUMENTATION	page	158
11.6	PERSONNEL	page	159
11.7	INSPECTION TABLES	page	159

INTRODUCTION

In the vast majority of industrial processes flammable substances or combustibles are stocked, handled or transported.

Excluding explosive or unstable chemical substances for which the danger is well recognized in nature, there is a high number of “unsuspected” elements that present characteristics able to create an explosion, under specific circumstances.

As a matter of fact, if the danger in some sectors such as the chemical or petrochemical is well known, it can be difficult to realize it in some working places that we could define as “ordinary”, such as agricultural industries, metalworking factories, carpentries, distilleries, sugar refineries, battery charging places, etc.

Actually, the major accidents happen in these places.

In recent history, the most significant case took place in Georgia (USA), in the *Imperial Sugar* factory where a whole sugar refinery was destroyed causing the death of 14 people and the injuries of 36 due to a blast triggered by the apparently harmless sugar dust.



Picture 1: blast of a sugar refinery

Unfortunately, as often happens, only these accidents can make the general opinion aware about possible situations or problems of risk.

The safety of working places is an example of this and in the last years we are witnessing an international massive campaign of arrangements and legislations aiming at improving the worker conditions and prevent these dangerous events as much as possible.

In this context the ATEX Directives regulate the manufacturing of equipment for use in potentially explosive atmospheres and worker safety conditions in those areas.

Chap.1: THE HISTORY

1.1 – HISTORICAL FACTS AND CURIOSITIES

The first discovered dangerous zone was inside coal mines where there was a double risk: the presence of methane and coal dust.

When the methane – air mixture was triggered, a minor explosion took place and this was enough to trigger a second and more violent explosion caused by the dust cloud which was created by the first one.

The first solution adopted by miners to solve these problems was to use a long pole with embers placed on the top to trigger the gas every day, so that there was not the possibility for the gas to accumulate in such a quantity to create an explosion that could produce a bigger one.

However, this solution to provoke “controlled explosions”, as easily understandable, represented many risks and soon the list of miners willing to make this procedure shortened. At first they recruited prisoners and then animals, which were sprinkled with water and equipped with a particular seat with a candle and sent over the mines with the hope to create only small blasts.



Picture 2: controlled explosions to avoid the accumulation of dangerous gas concentrations inside mines

The first type of protection inside mine industries was to ventilate the mines in order to markedly dilute the flammable gas and, as a consequence, reduce the limits of the explosion.

Regarding coal mines, in 1815 Sir Humphrey Davy invented what was called the “Davy lamp”, a particular oil lamp, that worked as a gas (firedamp) detector.



Picture 3: Davy lamp

If there was presence of fire damp, it overpassed the metal grille and came in contact with a small flame creating an increase of gas inside the lamp and a consequently gradual extension of the flame up to the switch-off, thus warning the miner about the danger.

The metal grille was very thin, in order not to allow the flame propagation through the screen.

Then, some low voltage signalling sirens were introduced in mines in order to control the functioning of the elevators. Since they worked at 12 V dc they were thought to be safe; but in 1912 and 1913 two disastrous explosions inside mines were caused by these devices.

The particular attention in the design of safer signalling sirens was the first step towards the development of an electrical equipment series suitable to be installed in potentially explosive atmospheres.

The first German regulation "*Protection of electrical installations in dangerous areas*" was published in 1935 as a guide line to the installation of electrical equipment inside hazardous areas.

A major change took place in 1938, dividing the regulation in two parts: one regarding the essential installation requirements and the other the principal requirements in product design.

The regulation concerning the product design included the fundamental concepts of the types of protection such as flameproof enclosure, oil immersion and increased safety.

All the components were designed in order to be protected and encased inside industrial enclosures that were resistant to atmospheric agents and weather conditions; this fact then brought to the development of flameproof components installed inside increased safety enclosures.

The devices designed to be in compliance with these normative requirements were marked with the Ex symbol for the first time.

In the sixties, the European Community was founded to set a free trade of products inside Europe; to achieve this target, the technical standards needed to be harmonised and for this reason they created the CENELEC.

This new system of European Standards (EN 50014 - EN 50020) published in 1972, was based on the Zone classification system of the IEC 60079-10.

The European Standards thus replaced the various National Standards and then the guidelines for application in Zone 0 (EN 50284) and Zone 2 (EN 50021) were issued.

In 1975 the first European Directive for equipment in hazardous areas was published and named "Explosion Protection Directive".

Chap.2: TECHNICAL ASPECTS

2.1 - EXPLOSION

An explosion is an oxidation-reduction reaction that provokes the formation of heat (highly exothermic reaction), usually combined with a visible flame.

The reaction happens only if there are the three following components present at the same place and time:

- **Fuel:** reducing agent, usually substances in the form of gases, vapours, dusts and fibers with specific physical properties and in definite volume concentration.
- **Combustive agent:** oxidative agent, typically the oxygen present in the air.
- **Ignition source:** any source of energy able to trigger the reaction.

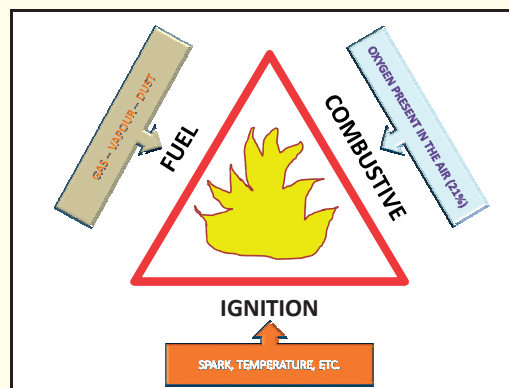

Picture 4: fire triangle

This situation is schematically represented by the *fire triangle* shown in Picture 4.

A relevant characteristic of an explosion is the high speed of reaction: once the reaction is triggered, a flame front is created and is physically expressed as a wave of pressure spreading in space and moving from the combusted mixture to the non-combusted surroundings.

The shorter is the distance from the explosion point the bigger is the effect: for this reason if an explosion happens in a confined volume, it will multiply its danger.

However, not all the fuel-combustive mixtures create a potentially explosive atmosphere: the conditions for a potential environment explosiveness are influenced by the physical and chemical characteristics of the fuels and trigger properties (energy of ignition) related to the fuel type.

2.2 – EXPLOSIVE ATMOSPHERE FROM GAS

2.2.1 – LIMITS OF INFLAMMABILITY

Any substance in the form of gas, vapour or mist can create an explosive atmosphere only when its concentration in the air is in a certain range between two limits, defined as lower and upper explosion levels which are expressed in volume percentage:

- **LEL** or *Lower explosion level* under which the combustible substance is in concentration in the air not enough to create an explosion, even if ignited.
- **UEL** or *Upper explosion level* above which the combustible substance is in concentration in the air not enough to create an explosion, even if ignited.

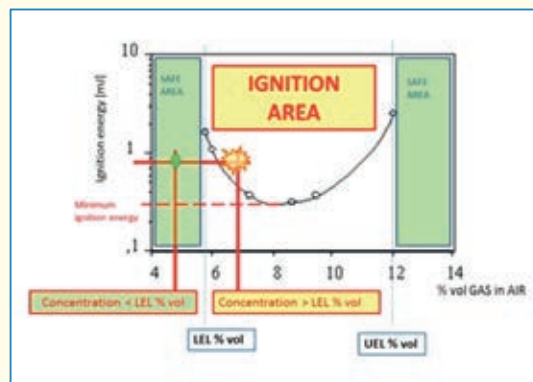

Picture 5: ignition area

The range between the two limits is defined as explosive or flammable range and corresponds to the potential ignition of the explosive atmosphere.

In Table 1, explosive limits of some flammable gases and vapours are quoted.

Substance	LEL [%Vol]	UEL [%Vol]	Substance	LEL [%Vol]	UEL [%Vol]
Etane	3	12,4	Acetylene	2,5	100
Methane	5	15	Benzene	1,3	7,9
Propane	2,1	9,5	Ethyl alcohol	3,3	19
Butane	1,8	8,4	Ammonia	15	28
Ethylene	2,7	37	Hydrogen	4,0	75
Propylene	2,4	11	Acetone	2,6	31

Table 1: inflammability limits of some substances

2.2.2 – MINIMUM IGNITION ENERGY

As said, one of the necessary elements of the explosion is the ignition source.

In order to ignite the atmosphere it is necessary a certain quantity of energy that varies according to the combustible concentration present in the mixture, with a parabolic pattern that tends to a minimum in correspondence with the stoichiometric concentration, defined as Minimum Ignition Energy (M.I.E.), and noticeably increases close to the inflammability limits.

The Minimum Ignition Energy, quoted in mJ, is thus the minimum energy which is necessary to trigger a potentially explosive mixture and is a characteristic of each substance.

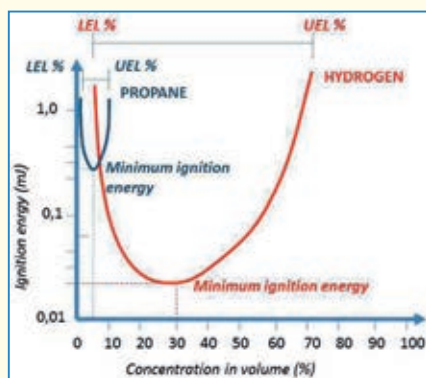

Picture 6: ignition areas of hydrogen and propane

Picture 6 represents the typical patterns of the ignition energy for hydrogen and propane according to the substance volume concentration in air; as it can clearly be inferred, the danger of hydrogen is much bigger as it has a wider explosive range and needs lower ignition energy to trigger the mixture.

Substance	MIE [mJ]	Substance	MIE [mJ]
Hydrogen	0,018	Metanol	0,215
Benzene	0,22	Carbon oxide	0,1
Acetylene	0,02	Ethylene	0,096
Methane	0,28	Propane	0,25
Acetone	1,15	Ammonia	>100

Table 2: minimum ignition energy of some substances

2.2.3 – FLASH POINT

If the explosive atmosphere is created by combustibles in the form of liquids, the parameter that must be taken into consideration is the *flash point*.

This is the minimum temperature at which vapours can be formed in such a quantity to mix with oxygen present in the air, creating a potentially explosive atmosphere.

This temperature value, of which some examples for flammable liquids are quoted in Table 3, usually corresponds approximately to the LEL, because these values are in some way linked to each other.

Substance	Tinf [°C]	Substance	Tinf [°C]
Diesel	+55	Acetone	-17
Benzene	-11	Ethyl alcohol	+12
Petroleum	-20	Methyl alcohol	+11

Table 3: flash point of some substances

2.2.4 – AUTOIGNITION TEMPERATURE

The *Autoignition Temperature*, as the name suggests, is the minimum temperature at which the combustible-combustive mixture ignites without the need of a third source of energy.

This specific value of the substance, together with the Minimum Ignition Energy, is essential in the gas classification, which is detailed in the next paragraph, and so in the selection of the suitable electrical equipment.

Even though the assessment of this value is highly influenced by the methods of testing and ambient conditions at which it is obtained, it is possible to find in literature some tables with illustrative values for each substance.

Substance	Tacc [°C]	Substance	Tacc[°C]
Gas oil	220	Acetone	540
Petrol	250	Hydrogen	560
Wood	220-250	Methyl alcohol	455

Table 4: Autoignition Temperature of some substances

2.2.5 – GAS CLASSIFICATION IN ATEX ACCORDING TO IEC/EN 60079 STANDARDS

To exactly know the basic characteristics of an electrical equipment for not igniting an explosive atmosphere, it is necessary to clearly define it according to the type of combustible substance.

This is possible thanks to the gas classification detailed in Sheet 1.

IEC/EN 60079 standards classify the gases in *groups* based on the Minimum Ignition Energy and assigns *temperature classes* according to the Autoignition Temperature.

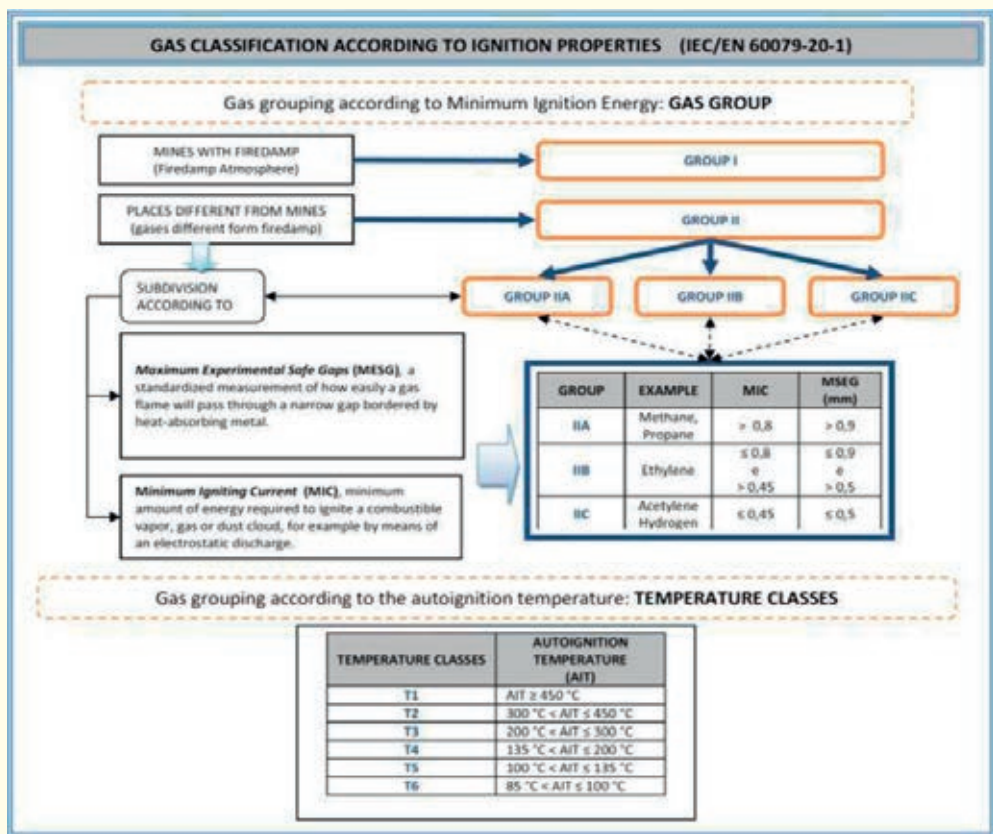

Sheet 1: Gas classification according to IEC/EN 60079

2.3 – EXPLOSIVE ATMOSPHERE FROM DUST

If the danger related to gas, or anyway flammable liquids, is well known by everyone, maybe it is not so intuitive to connect the risk of an explosion with the presence of dust or combustible particles.

This is even more emphasized as the combustible dust often comes from the working, handling or stocking of materials, such as aluminium, which are clearly non-flammable at the solid state.

A dust is defined as a combination of solid particles that can deposit because of the weight or can stay suspended in the air for a certain period of time.

Not all the dusts can be combustible. Generally the dusts having particle size less than 0,5 mm can react with oxygen present in atmospheric condition once they are suspended in the air.

The danger linked to combustible dust increases in an inversely proportional way to the particle size and can be due to:

- formation of a **dust cloud**

In this case, the dust suspended in the air forms a combustible cloud that, helped by the dimensions, tends to mix with oxygen creating a potentially explosive atmosphere. This is the typical case of the industrial sector during normal operations of a production cycle, from the removal of a bit of wood to the machine cleaning.

- formation of a **dust layer**

In this case, the dust deposited because of the weight can create layers that, if not removed, can reach thicknesses of tens of millimeters.

A dust layer can principally be hazardous for two reasons:

- it can raise and create a cloud caused by an air movement or, in the worst case, as an effect of a previous explosion. As a matter of fact, the wave of pressure generated by an explosion caused by a dust cloud can usually raise the deposited layers in the surroundings determining new clouds that immediately ignite, creating a dominoes effect with potentially devastating consequences;
- it can contribute to decrease the thermal dissipation of an equipment, with a consequent increase of temperature and ignition danger.

For dusts, the concept of the fire triangle is extended, picture 7, as the necessary conditions for creating an explosion are more than three:

- the dust must be combustible
- it must be spread in the air to create a cloud – presence of oxygen (combustive)
- it must have a certain particle size (less than 0,5 mm)
- the concentration must be within the range of a defined explosive range
- it needs an ignition source

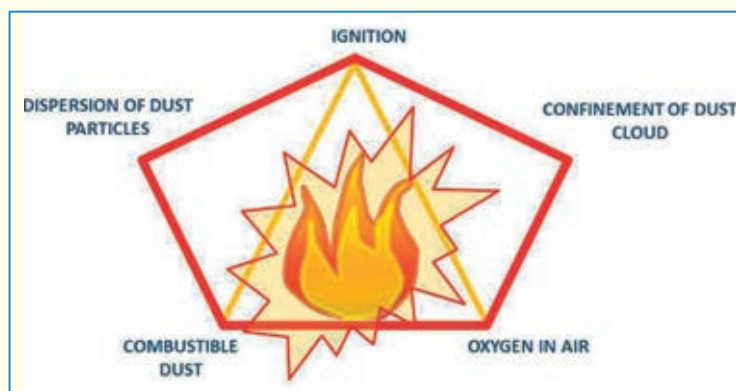

Picture 7: fire pentagon

2.3.1 – EXPLOSIBILITY LIMITS

As already mentioned, also dusts are defined within an explosive range according to the concentration in air.

The limit concentrations are defined **LEL** and **UEL** as for gases but are expressed in mass for air volume unit (g/m^3) and defined in atmospheric conditions. For concentrations lower than the LEL the distances between particles are so high that the heat caused by the oxidation-reduction of one of them is not enough to ignite those of the surroundings.

The limit of lower explosion level of dusts is usually a value between $20\text{g}/\text{m}^3$ and $100\text{g}/\text{m}^3$. Anyway, when the dust concentration does not exceed $10\text{g}/\text{m}^3$ it is considered a safety condition and thus it is a reference LEL in potentially explosive atmosphere assessment.

2.3.2 – MINIMUM IGNITION ENERGY

Dusts, as gases, require a Minimum Ignition Energy to trigger an explosion: in this case it depends on the chemical and physical properties and particle size of the dust.

It is typically quoted in some tens of *mJ* and thus presents bigger values than gases.

Dusts	MIE [mJ]	Dusts	MIE [mJ]
Coffee	25	Magnesium	30
Active carbon	100	Vitamine B1	35
Cellulose	45	Aspirin	15
Wood	20	Sugar	45
Polyethylene	20	Sulphur	35

Table 5: Minimum Ignition Energy for some combustible dusts

2.3.3 – IGNITION TEMPERATURE AND GLOWING TEMPERATURE

In the case of dusts, there are two important temperature values:

- T_{ci} (IT ignition temperature) - minimum ignition temperature of a dust cloud
- T_l (GT glowing temperature) - minimum ignition temperature of a dust layer with “l” thickness (usually considered 5 mm) on a hot surface.

Both these values are important to define the temperature limit that a surface of an electrical equipment can reach in order to increase safety.

2.3.4 – ELECTRICAL RESISTIVITY

The solid material producing dust can be electrically conductive.

In order to be considered conductive, a dust must have a resistivity value lower or equal to $10^3 \Omega m$. In potentially explosive areas, the presence of conductive dusts on the surface of an electrical equipment enclosure or in its internal can be dangerous as it tends to condition the dielectric characteristics favouring:

- the formation of an electric arc between parts with different potential, caused by the reduction of insulating distances in air
- surface discharge phenomena
- *tracking* phenomena (the dust is deposited on the surface and for its characteristics produces a conductive track that allows the current flowing).

For these reasons, the electrical resistivity of a dust is an important parameter that, as we will see in the next paragraph, is the base for dust classification as per IEC/EN 60079 standards.

2.3.5 - DUST CLASSIFICATION IN ATEX ACCORDING TO IEC/EN 60079 STANDARDS

Same as for gases, IEC/EN 60079 standards regulate the dust classification in groups, according to conductivity properties as per the visual scheme of Sheet 2.

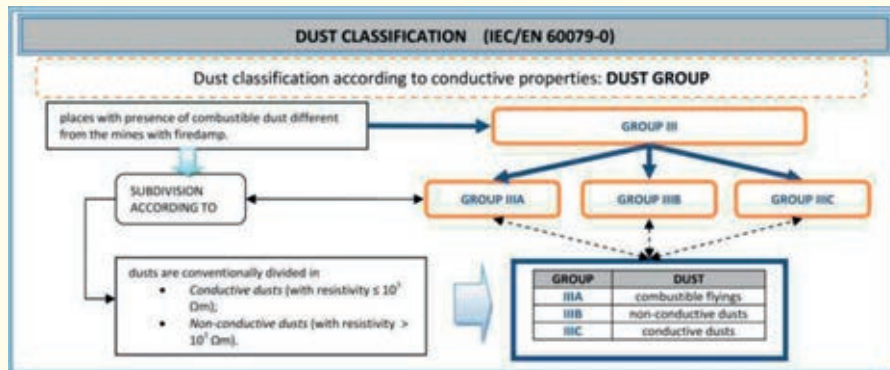

Sheet 2: dust classification according to IEC/EN 60079

2.4 – ELECTRICAL IGNITION SOURCES

The ignition risk of an explosive atmosphere for an electrical equipment is in the ordinary operation. As a matter of fact, the energy levels which are normally produced are much bigger than the value of the minimum ignition energy of gases, liquids and dusts.

In order to protect an electrical equipment from the surrounding environment the habit is to use enclosures that, other than reducing the risks of direct contact with live parts, also offer protection against mechanical solicitations and undesired penetrations of liquids or dirt.

For this reason, the enclosure of the equipment becomes central in potentially explosive atmospheres as it is the element between what it contains and the surroundings. Thus, the

mechanical and thermal characteristics of the enclosure material become the main elements to avoid the ignition of an explosive atmosphere.

The main ignition sources produced by an electrical device are:

- formation of **electric arc**
- **surface temperature**
- **electrostatic discharge**

2.4.1 – *ELECTRIC ARC*

An electrical equipment designed to control or insulate the circuits of an electrical plant can produce an *electric arc*, both in normal operation or in case of fault, and this is principally due to:

- shortcircuits
- overvoltages
- surface deterioration and insulation weakening (tracking)
- use of MCBs

All these elements produce energy levels much higher than the minimum values of ignition for gases and dusts, and so the risk is very high.

An electrical equipment which can produce an electric arc in normal operation or in case of fault is called “sparking”.

2.4.2 – *SURFACE TEMPERATURE*

The increase of temperature, generated by the Joule effect of an electrical current flow, causes the warming of the electrical equipment.

During the normal operation or in case of fault (as it can be a short-circuit, overvoltage or bad contact) the temperature of the enclosure increases and can become dangerous in presence of an explosive atmosphere.

The temperature increase can become the ignition source if the achieved value is higher than the Autoignition Temperature of the mixture.

2.4.3 – *ELECTROSTATIC DISCHARGE*

The electrical equipment material is very important for what concerns the accumulation of electrostatic charges.

As a matter of fact, where there is an accumulation of electrostatic charge the contact with parts with different potential, as people or moving machines, provokes an electrostatic discharge physically represented by a spark that can ignite a potentially explosive mixture.

Researches confirmed that the static electricity accumulated by a person can reach 135 mJ, value which is enough to ignite the vast majority of explosive mixture between air and gas or air and dust.

Some examples of industrial operations with charge separation and then potentially electrostatic discharge are:

- charge and discharge or cleaning operations (by means of water or high-pressure vapour) of tanks or silos that contain flammable liquids or combustible dusts
- working processes such as metal sandblasting
- movement of liquids or dusts on transport system with speed higher than 1m/s.

Chap.3: ZONES AND PROTECTION LEVELS

3.1 – SOURCES OF RELEASE AND ZONE CLASSIFICATION

The notion of zone, the base of hazardous area classification, has been introduced in order to simplify the selection and installation of safe electrical equipment inside environments where there is the possibility of an explosive atmosphere due to the presence of gas and/or combustible dusts.

In an installation or environment with potential explosion risk, a *source of release* is a point from which a flammable substance can be emitted in such a way that can produce an explosive atmosphere, both during normal operations or predictable faults.

This is defined according to how frequently the source can emit the hazardous substance. For this reason, in the years some mathematical models have been created based on the interaction of the ambient parameters (temperature, pressure, ventilation, etc.) and operative conditions that involve the hazardous substance, as times, means and temperatures of release.

IEC standards system, particularly IEC 60079-10 establishing basic rules for the classification of hazardous areas both in presence of gases or combustible dusts, refers to a particular calculation model, defined *IEC zone system*.

This model is based on explosive atmosphere formation probability and duration that become thus the basic parameters to classify dangerous zones.

The zones acquire different numbers in case of presence of gases or combustible dusts as shown in Tables 6 and 7.



GAS EXPLOSIVE ATMOSPHERE				
IEC 60079-10-1	ZONE 0	ZONE 1	ZONE 2	
		An area in which an explosive atmosphere, consisting of a mixture with air and flammable substances in the form of gas, vapour or mist, is present continuously or for long periods or frequently .	An area in which an explosive atmosphere, consisting of a mixture with air and flammable substances in the form of gas, vapour or mist, is likely to occur in normal operation occasionally.	Area in which an explosive atmosphere, consisting of a mixture with air and flammable substances in the form of gas, vapour or mist is not likely to occur in normal operation but, if it does occur, will persist for a short period only .
Preferred symbols				
	Explosive atmosphere duration			
	> 1.000 h/year	10 ÷ 1.000 h/year	0,1 ÷ 10 h/year	
USA CAN	DIVISION 1		DIVISION 2	

Table 6: definition of zone - GAS

DUST EXPLOSIVE ATMOSPHERE				
IEC 60079-10-2	ZONE 20	ZONE 21	ZONE 22	
		An area in which an explosive dust atmosphere, in the form of a cloud of dust in air, is present continuously , or for long periods or frequently .	An area in which an explosive dust atmosphere, in the form of a cloud of dust in air, is likely to occur in normal operation occasionally.	An area in which an explosive dust atmosphere, in the form of a cloud of dust in air, is not likely to occur in normal operation but, if it does occur, will persist for a short period only .
Preferred symbols				
	Explosive atmosphere duration			
	> 1.000 h/year	10 ÷ 1.000 h/year	0,1 ÷ 10 h/year	
USA CAN	DIVISION 1		DIVISION 2	

Table 7: definition of zone - DUST

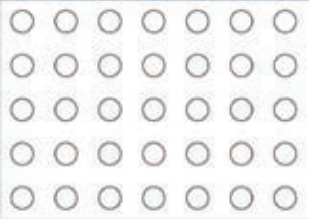
The zone classification according to IEC 60079 standards applies internationally and has been harmonised by CENELEC as European standards (EN 60079-10-1 for gas, EN 60079-10-2 replacing EN 61241-10 for dust).

North-American countries such as USA and Canada follow the guidelines by National Electrical Code (NEC) e Canadian Electrical Code (CEC), with rules which are different but present some similarities:

CLASS I	flammable gases, vapours or mists
CLASS II	combustible dusts
CLASS III	ignitable fibers or flyings

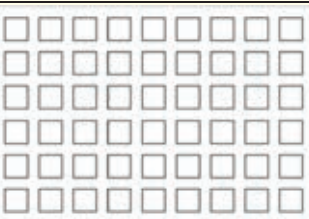
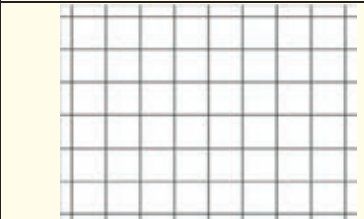
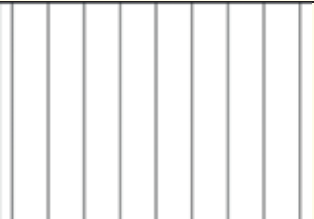
The classification of hazardous areas according to North-American Standards presents only two zones, called *divisions*.

DIVISION 1	Area in which hazardous concentrations of combustibles are present continuously
DIVISION 2	Area in which hazardous concentrations of combustibles are not present continuously

The article 505 of the NEC provides the possibility of classification according to IEC standards and products in compliance with IEC 60079 standards but the equivalence is not always exact and accepted: products certified for zone 1 for example do not automatically meet requirements for Division 1 as this includes also zone 0 of the IEC scheme.

Some typical examples of zones, classified according to IEC zone system, are analyzed in chapter 10.

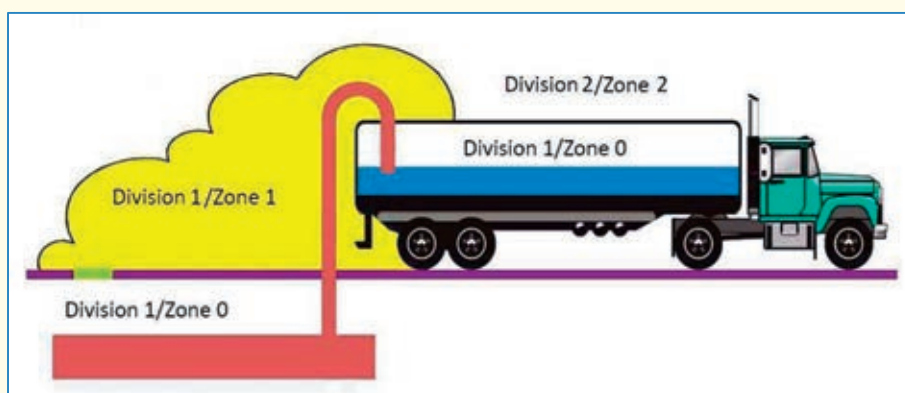

Picture 8: zones and divisions

3.2 – EQUIPMENT PROTECTION LEVEL-EPL

The safety level of an electrical equipment is substantially the ability to avoid the ignition under specific operating conditions.

In order to do this, an electrical equipment must:

- not spark or provoke electric arc
- avoid dangerous surface temperature
- be made of materials which do not accumulate electrostatic charge

The capability to satisfy these characteristics must be maintained in time and be evaluated in the following conditions, to be declared by the manufacturer:

- **normal operation**
- in presence of a **predictable fault**
- in presence of a **second fault (rare)**, depending on the previous one.

According to the danger of the area for which the equipment is intended, there are different *Equipment Protection Levels, EPL*, that substantially express what said before with the use of an acronym, composed of a first letter that identifies the type of substance present in the explosive atmosphere (G for Gas and D for Dust) and a second letter that characterizes the protection level (“a”, “b” or “c”).

The following sheet clarifies it and shows the link between zone and protection level.

The protection level is very important as it allows to immediately understand in which hazardous zone an EX product can be installed.

EQUIPMENT PROTECTION LEVEL vs HAZARDOUS ZONES (IEC/EN 60079)

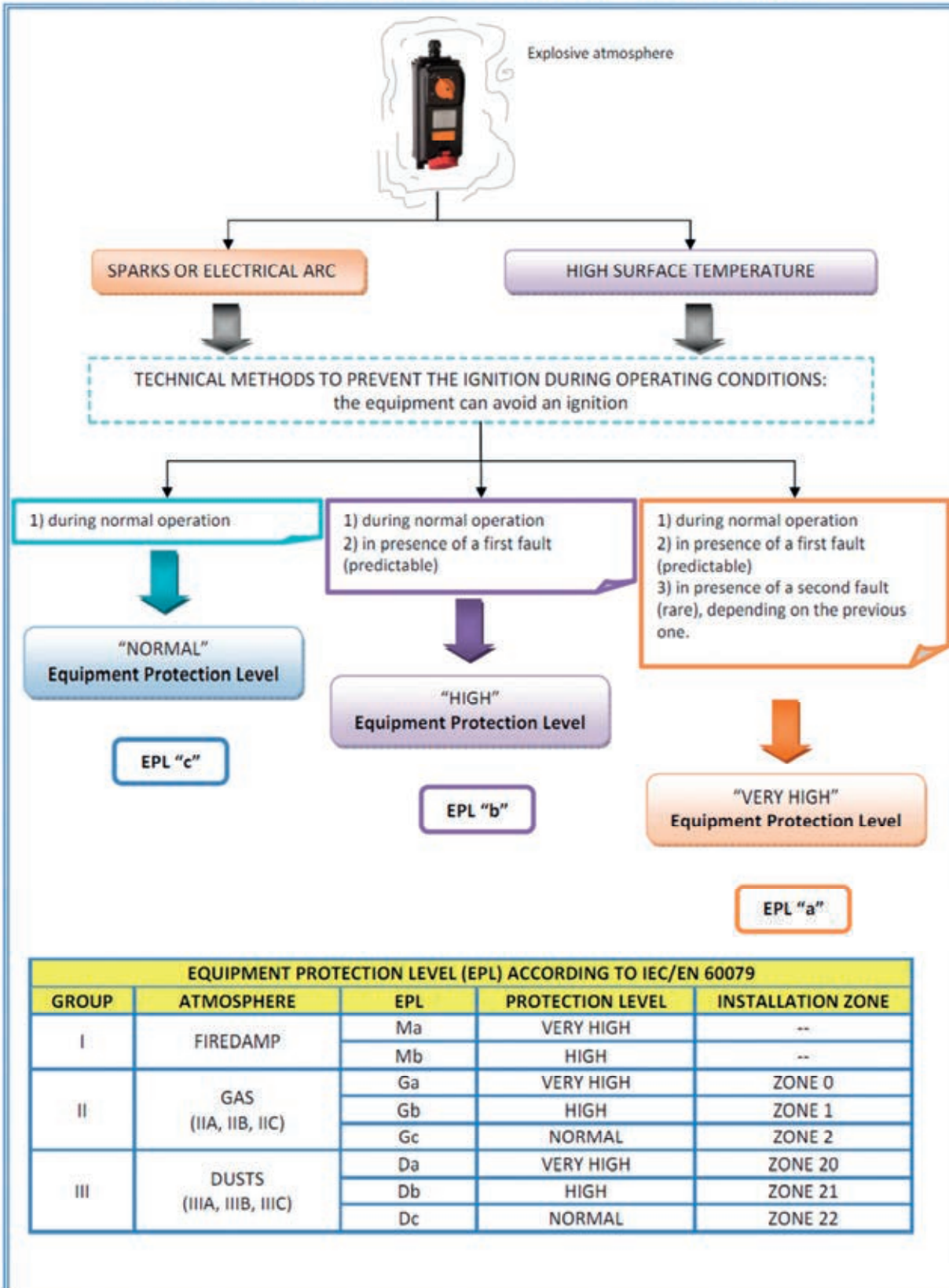

Sheet 3: EPL – zone correspondence

Chap.4: TYPES OF PROTECTION

4.1 – TYPES OF PROTECTION

How does an electrical device reach the Equipment Protection Level explained in the previous chapter?

By the way it is necessary to introduce the *types of protection*: they are substantially construction methods for equipment (electrical or not) that involve the selection of materials, dimensions and the designing of enclosures and internal components, aiming to minimize the possibility to ignite an explosive atmosphere.

The types of protection are different according to the type of equipment, explosive atmosphere and ways in which the ignition is avoided. Moreover, since they are the basic principles to define the protection levels, they are characterized according to their operating conditions (normal operation, predictable fault, rare fault).

Types of protection, levels of protection and hazardous zones are closely related to each other, as shown in Sheet 4.

The types of protection are defined inside IEC/EN 60079 standards (from part 1 on) and can be divided in three macro-families according to the techniques which are used to avoid the explosion, as shown in Table 8.

TYPES OF PROTECTION		
CONTAINMENT	SEGREGATION	PREVENTION
It allows the explosion to occur inside the enclosure but not to propagate outside	It avoids the contact between hot points and potentially explosive atmospheres	It increases the reliability of electrical components, limiting hot points and sparks
Example: “d” – flameproof enclosures	Examples: “m” - encapsulation “o” – oil immersion “p”- pressurization “t” – by enclosure	Examples: “e” – increased safety “i”- intrinsic safety “n”

Table 8: division of types of protection

They are indicated with small letters (“d”, “e”, “m”, “n”, “i”, “p”, “o” for gas and “i”, “m”, “t”, “p” for dust) preceded by the letters Ex indicating the compliance with IEC/EN 60079 standards.

In some cases, the identification letters of the types of protection are followed by those relative to protection levels.

Regarding the characteristics of each type of protection, the standards (IEC/EN 60079-1 and followings) establish the design requirements and the tests that must be done on the equipment to check the protection efficiency.

In the following paragraphs, all these types of protection will be detailed with examples of materials used and possible applications.

GASES

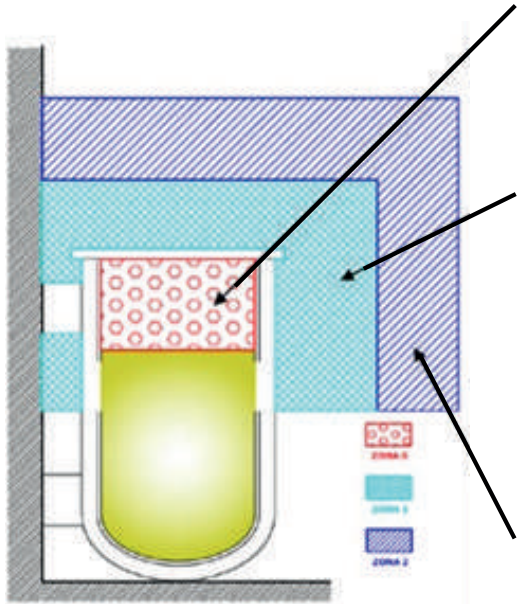

SYMBOL	TYPES OF PROTECTION	EPL	ZONE
ia	Intrinsic safety	Ga	0
ma	Encapsulation		

SYMBOL	TYPES OF PROTECTION	EPL	ZONE
d	Flameproof enclosures	Gb	1
p,px,pz	Pressurization		
q	Powder filling		
o	Oil immersion		
eb	Increased safety		
ib	Intrinsic safety		
mb	Encapsulation		

SYMBOL	TYPES OF PROTECTION	EPL	ZONE
pz	Pressurization	Gc	2
ic	Intrinsic safety		
nA,eC	Increased safety		
nC	Sparking devices		
nR	Restricted breathing enclosure		
mc	Encapsulation		

DUSTS

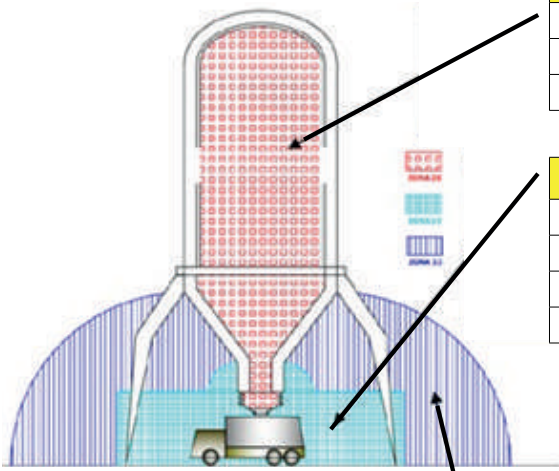

SYMBOL	TYPES OF PROTECTION	EPL	ZONE
ia	Intrinsic safety	Da	20
ma	Encapsulation		
ta	Protection by enclosure		

SYMBOL	TYPES OF PROTECTION	EPL	ZONE
ib	Intrinsic safety	Db	21
mb	Encapsulation		
tb	Protection by enclosure		
pD	Pressurization		

SYMBOL	TYPES OF PROTECTION	EPL	ZONE
ic	Intrinsic safety	Dc	22
mc	Encapsulation		
tc	Protection by enclosure		
pD	Pressurization		

Sheet 4: types of protection - EPL – zones correspondence

4.1.1 – FLAMEPROOF ENCLOSURES Ex-d

The type of protection **Ex-d** provides the use of particular enclosures that can contain non-Ex marked components (sparking or not) and allows not only the ingress of explosive atmospheres (in this case Gas) but also the ignition of it.

These enclosures, generally made of metallic material (aluminium alloys, steel or cast iron), guarantee the resistance to the pressure generated by the explosion and are designed in such a way that the joints (named as *flameproof joints*) are long and have interstice enough not to permit the outgoing of flames, avoiding the ignition of the explosive atmosphere, Picture 9.

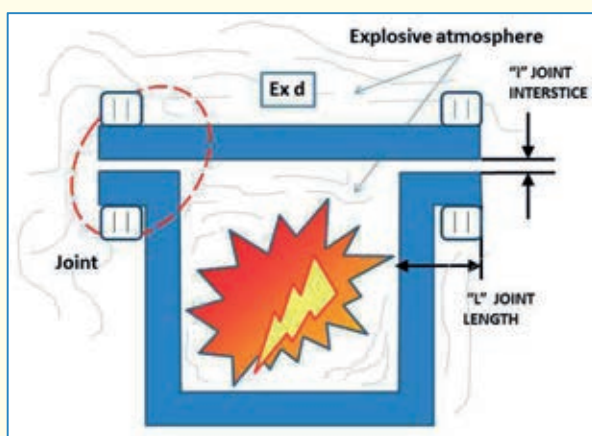

Picture 9: type of protection Ex d

As it can easily be inferred, the level of protection that can be guaranteed is high, EPL Gb, that makes the equipment suitable to be installed in zone 1.

Some typical installations are low voltage equipment such as electrical distribution boards, switches, transformers, low and medium voltage motors and all those devices that, during the normal operation, can spark or cause high temperatures.

The reference standard is IEC/EN 60079-1.

4.1.2 – INCREASED SAFETY Ex-e

The Ex-e protection mode (increased safety) applies to electrical equipment and components with both "eb" (EPL "Mb" or "Gb") protection level and "ec" (EPL "Gc") protection level. The protection mode "eb" applies to equipment with nominal voltages ≤ 11 kV in d.c. or c.a, while the protection mode "ec" is applied to equipment with nominal voltage ≤ 15 kV in d.c. or c.a.

Some complementary measures are envisaged (increased isolation distances in air, use of specific and marked Ex components, etc.) to provide increased safety against the formation of arcs or sparks or against the possibility of reaching too high temperatures.

In this case, the ignition is avoided even if the explosive atmosphere is in contact with the internal elements and therefore is a suitable protection method for all types of gas.

The temperature class of the equipment is defined based on the maximum temperature reached by any part of it (external or internal) during the type tests, according to the reference standard (IEC / EN 60079-7).

For the case of the equipment, at least IP54 is required to prevent the entry of solid bodies or water that could affect the insulation distances of the components.

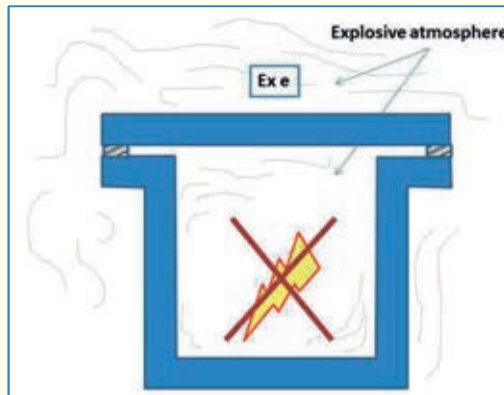

Picture 10: type of protection Ex e

Usually the components used for this type of protection must be ATEX certified with a protection mode compatible with increased safety.

The EPL Gb protection level allows the equipment to be installed safely in zone 1, while the EPL Gc protection level is suitable for the installation of equipment in zone 2.

Usually these are very sturdy plastic or metal enclosures with elastomer gaskets to maintain the IP rating.

Typical application examples are certainly the junction / junction boxes, terminals and terminal boards, electromagnets, coils, rotating electrical machines and lighting devices.

4.1.3 – INTRINSIC SAFETY Ex-i

The type of protection with intrinsic safety **Ex-i** is based on the limitations of energy that the circuit can generate so that it will not ignite the explosive atmosphere.

The intrinsic safety equipments are suitable for all kinds of gases. According to the gas, and thus to the minimum energy ignition, it is necessary to define the dedicated intrinsic safety type of protection. It is not a type of protection relative to a single equipment but to a whole system that is generally composed of two parts:

- an equipment or a single component with intrinsic safety placed inside the hazardous area
- a combined electrical device (that can be placed inside or outside the hazardous area and is usually connected with a multi-pole cable), named *safety barrier*, used to supply the equipment, keeping a reduced value of energy produced. If it is placed in a hazardous area, it requires a type of protection suitable for the zone in which it is installed.

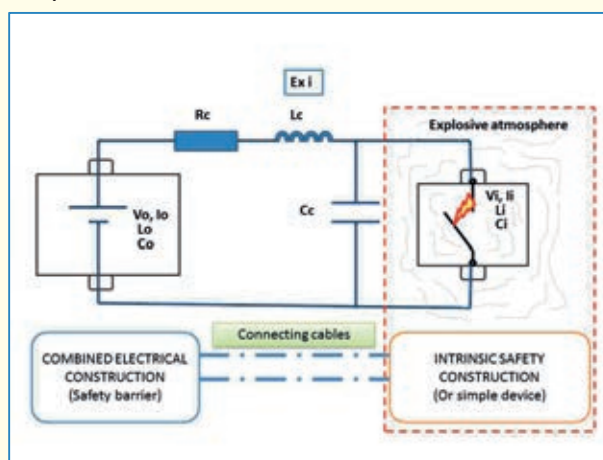

Picture 11: type of protection Ex i

It is a type of protection that can guarantee all the three protection levels; thence both for gas and for dust the letter “i” which stands for intrinsic safety is combined with another letter (“a” “b” or “c”) which identifies the protection level.

Interesting application examples are mainly in measuring tools and electronic components, such as sensors, transducers, monitoring and control circuits, etc.

4.1.4 - ENCAPSULATION *Ex-m*

The type of protection by means of encapsulation **Ex-m**, reference standard IEC/EN60079-18, concerns both dust and gas.

The parts or components of the equipment that can potentially ignite an explosive atmosphere are encapsulated by means of resins, typically thermoplastic, thermosetting or epoxide, so that they insulate the hazardous atmosphere.

The resin must stand the operating temperature declared for the equipment and is tested in climatic chamber to verify the maintaining of the characteristic after ageing.

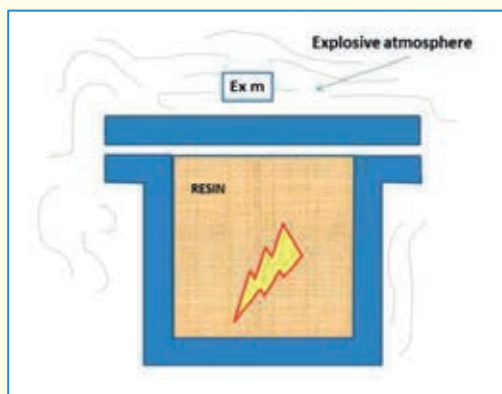

Picture 12: type of protection *Ex m*

Even though this type of protection guarantees a good electric insulation and discrete characteristics of mechanical protection, it is not possible to make any maintenance; in fact in case of fault it is necessary to replace the whole equipment.

As for the intrinsic safety, even the encapsulation is a type of protection that can guarantee all the three levels of protection; for this reason both in gas and dust, the letter *m* of the encapsulation is followed by the three letters (“a” “b” or “c”) according to the level of protections.

4.1.5 – TYPE OF PROTECTION *nA-nC-nR*

The types of protection “n” can guarantee the protection against a gas explosive atmosphere only during normal operation and are thus suitable only for Zone 2.

The three types of protection described by IEC/EN 60079-15 standard are:

- **nC** or **sparking** electrical devices or components
- **nA** or **non-sparking** electrical devices or components
- **nR** or electrical devices with **restricted-breathing** enclosure

nC- sparking electrical devices or components

It is a type of protection suitable for sparking components and includes:

- **nC- hermetically sealed:** the protection is guaranteed by the enclosure that is sealed in order to avoid the ingress of explosive atmosphere; the main protection is the sealing that, together with the enclosure, must guarantee the maintaining of the operation in time at the temperature declared for the device.
- **nC- enclosed break:** the ingress of explosive atmosphere is prevented, but the external explosive mixture must not be triggered; for this reason they are tested to verify the functioning (the standard prescribes 10 On-Off for the device).
- **nC- non-incendive components:** they are substantially similar to the previous ones but the tests are harsher (the standard prescribes 50 On-Off for the device). It is not suitable for all the kinds of gases and according to the type of tested mixture, it is necessary to declare the group II to which it refers.

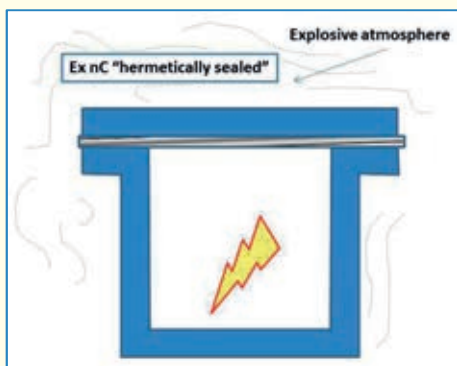

Picture 13: type of protection Ex nC (hermetically sealed)

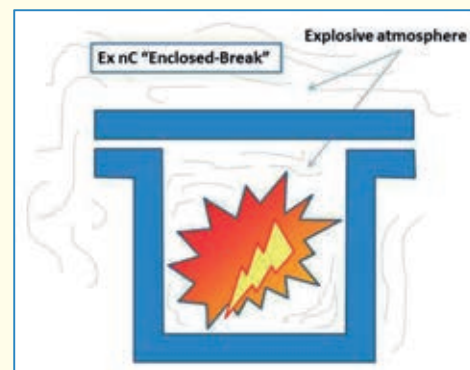

Picture 14: type of protection Ex nC (enclosed break)

nA- non-sparking electrical devices or components

It is a type of protection indicated only for non-sparking components.

The containing enclosure of the device must guarantee a minimum IP54 protection rating for the powered parts, to avoid the ingress of external bodies or water.

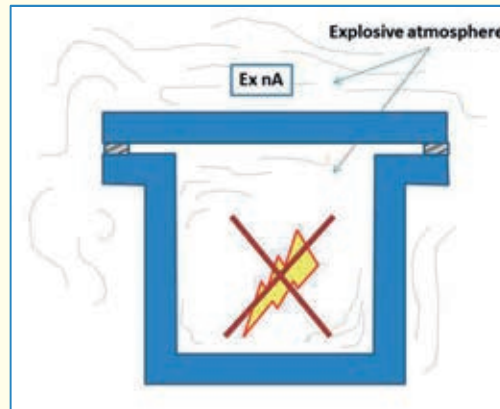

Picture 15: type of protection Ex nA*

The ingress of explosive atmosphere is prevented and the protection is guaranteed by the intrinsic characteristics of internal components and the maintaining of the insulating distances.

It is suitable for all the kinds of gases of group II and typical examples of application are lighting devices, terminal boards and junction or terminal boxes.

*The "nA" protection mode is no longer present in the new edition of EN 60079-15: 2019 (at the current date not yet harmonized), but it is still usable since the previous edition of the standard (EN 60079-15 : 2010) will be valid until 19 April 2022. After this date, the "nA" mode of protection will be formally replaced by the protection mode "ec" according to EN 60079-7: 2015.

nR- electrical devices with **restricted-breathing** enclosure

It is a type of protection that can be used both for sparking and non-sparking components, and the protection is guaranteed by the limitation of power dissipation (and then the temperature delta between the device and the surrounding environment), so that the created depression once it is de-energized delays the ingress of explosive atmosphere for a limited time prescribed by the standard.

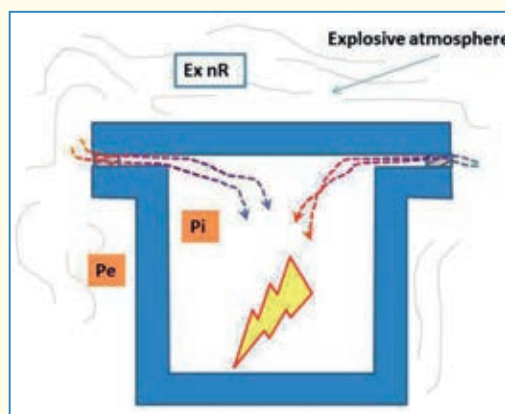

Picture 16: type of protection Ex nR

4.1.6 – OIL IMMERSION Ex-o

Ex-o is a type of protection for gas that consists of immersion of electrical devices or parts in a protection liquid (usually mineral oil) in order to prevent the ignition of the explosive atmosphere externally or internally. The reference standard is IEC/EN 60079-6.

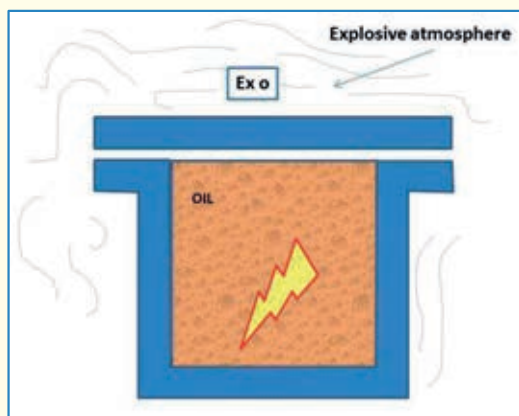

Picture 17: type of protection Ex o

It is applied to components or Ex devices that without oil do not spark or trigger an explosive atmosphere during the normal operation (for example devices with type of protection nA) and with the adding of a liquid they can guarantee protection in case of a first fault and with Gb protection level, suitable to be installed in zone 1.

Anyway, it is not one of the most diffused type of protection due to the difficult maintaining.

4.1.7 – POWDER FILLING Ex-q

Ex-q is a type of protection for gas that consists of fulfilling of components or parts of the electrical device with a material in order to prevent the ignition of the explosive atmosphere outside or inside the enclosure, that must be minimum IP54 rated.

The ingress of explosive atmosphere in this case is prevented through the presence of the filling material, because the flame cannot propagate externally.

It is suitable for zone 1 and applies to electrical devices and Ex components with rated current equal to or less than 16 A, rated voltage equal to or less than 1000 V and rated power equal to or less than 100 W.

The powder filling is rarely used for the same reasons of the oil immersion.

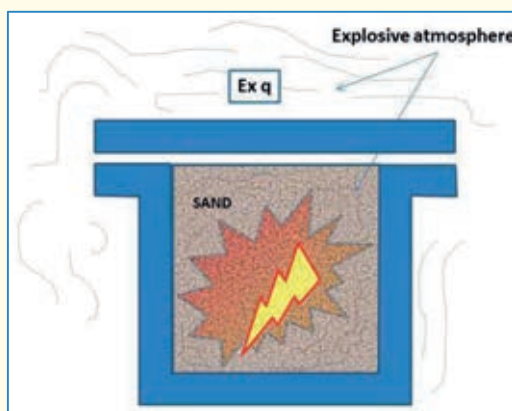

Picture 18: type of protection Ex q

4.1.8 – PRESSURIZED ENCLOSURE Ex-p

Ex-p is a type of protection used for electrical equipment of big dimensions and high power, such as motors or generators, power switchboards, electrical cabins, control systems for industrial processes, etc.

The ingress of explosive atmosphere is prevented by the presence of a protective gas (for example air) inside the enclosure kept at constant pressure higher than the external atmosphere.

The internal components do not need to be ATEX marked.

A device protected by internal pressurization is typically composed of the following elements:

- a casing
- protective gas supply unit
- protective gas discharge unit
- control unit for washing and pressure (that must be protected by one or more types of protection suitable for the zone where it is installed, or not protected if installed in a safe area)

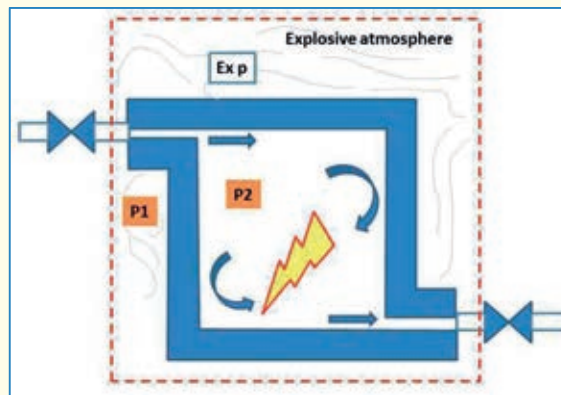

Picture 19: type of protection Ex p

This type of protection can be divided in three different ways according to the conditions for the prevention of the ignition:

- **px** – inner pressurization that reduces the classification within the enclosure from Zone 1 to a safe area (Epl from Gb to non-hazardous)
- **py** - inner pressurization that reduces the classification within the enclosure from Zone 1 to Zone 2 (Epl from Gb to Gc)
- **pz** - inner pressurization that reduces the classification within the enclosure from Zone 2 to a safe area (Epl from Gc to non-hazardous)

4.1.9 – PROTECTION BY ENCLOSURES Ex-t

The protection by enclosure Ex-t is a type of protection for dust suitable for any kind of electrical device (sparking or not during normal operation) and dangerous zone (20, 21, 22 according to specific requirements that the enclosure must satisfy).

The internal components can be standard as the ingress of explosive atmosphere (combustible dust) can be prevented through particular attention to the parts of the enclosure that are the interface between the enclosure and the surrounding environment (joints, cable entries, etc.).

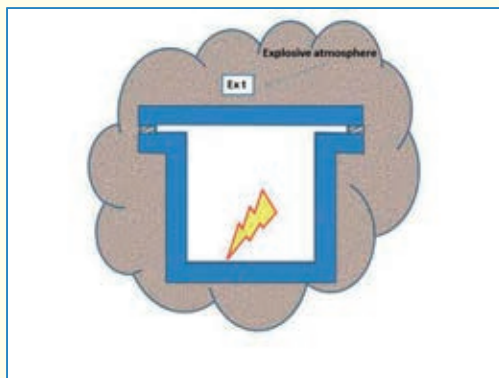

Picture 20: type of protection Ex t

According to the zone and the type of combustible dust, the protection against the entry of explosive atmosphere is guaranteed through the minimum requirement of IP rating, as per Table 9.

<i>Epl</i>	Group III		
	<i>IIIA - combustible flyings</i>	<i>IIIB - non-conductive dust</i>	<i>IIIC - conductive dust</i>
<i>ta</i>	IP6X	IP6X	IP6X
<i>tb</i>	IP5X	IP6X	IP6X
<i>tc</i>	IP5X	IP5X	IP6X

Table 9: minimum IP rating required as per type of zone

The reference standard is IEC/EN 60079-31.

In this case, it is crucial the choice of the materials (both for the enclosure and the gaskets) that must ensure the characteristics of mechanical, thermal and light resistance in order to guarantee the maintaining of the IP rating.

4.1.10 – PROTECTION BY “COMBINED” TYPES OF PROTECTION

The above explained types of protection can be also combined with each other.

There are many electrical equipments with two or more different types of protection applied to different parts of the same device.

For this reason, there are also complex devices where each part or component must satisfy the essential requirements of each reference standard.

In this case, the symbols of the type of protection must be reported in alphabetical order. Some indicative examples are flameproof (Ex-d) control devices inserted in increased safety (Ex-e) enclosures that together are marked **Ex d e**.

Another common example is when a powder-filled component (Ex-m) is installed inside an increased safety device (Ex-e) that together are marked **Ex e mb**.

Chap.5: REQUIREMENTS FOR EX DEVICES

The requirements that must be respected by all the electrical devices intended to be used in potentially explosive atmospheres can be found in EN 60079-0 standard.

It is not only described how to classify different devices according to the type of explosive atmosphere, but also the characteristics that the material must have to prevent the ignition.

This “general” rule applies then to the specific type of protection, where it is re-called in some requirements.

Some of the main standard requirements will be detailed in the following paragraphs.

5.1 – CLASSIFICATION OF ELECTRICAL EQUIPMENT FOR GAS ACCORDING TO IEC/EN 60079-0

The electrical equipment intended for use in “gas” potentially explosive atmosphere are divided in **groups** (GROUP I, GROUP II) and subgroups according to the gas classification described in chapter 2 and reported in Table 10.

EQUIPMENT GROUPS			
I	Electrical equipment intended for use in mines susceptible to firedamp.		
II	Electrical equipment intended for use in places with an explosive gas atmosphere:		
	IIA	IIB	IIC
	Propane, methane, benzene ecc.	Ethylene	Hydrogen, Acetylene

Table 10: classification of equipment as per IEC/EN 60079-0 - GAS

As it can easily be inferred, the equipment which is suitable to be installed in the most hazardous area with presence of a gas from group IIC (the most dangerous) will be suitable for the same zone also when there is a gas from groups IIB and IIA; it is not possible the contrary, as shown in Table 11.

Group of flammable substances	I	Groups and subgroups of Ex equipment	I
	IIA		IIA, IIB, IIC
	IIB		IIB, IIC
	IIC		IIC

Table 11: correspondence between the groups of substances and equipment

Other than being divided in groups and subgroups, in IEC/EN 60079-0, the devices are classified according to the maximum surface temperature that they can generate during their operation declared by the manufacturer.

For an Ex equipment the maximum surface temperature is the maximum temperature reached by its surface parts when powered with electrical parameter harsher than the operating ones.

This temperature is the necessary parameter to define the temperature class where the equipment is classified and must be declared in the marking.

Table 12 clearly shows the equipment temperature class according to the ignition temperature of gases, other than the maximum surface temperature allowed to be safe and avoid ignition of the gas (considering a small safety margin).

GROUP II		
Equipment temperature class	Maximum surface temperature	Gas ignition temperature
T1	450°C	>450°C
T2	300°C	>300°C
T3	200°C	>200°C
T4	135°C	>135°C
T5	100°C	>100°C
T6	85°C	>85°C

Table 12: correspondence between the temperature class and the gas ignition temperature

As for the groups, also for the temperature class when an equipment is classified as T6, it means it is suitable also for all the other classes (from T5 to T1) while the contrary is not valid, as indicated in Table 13.

Substance temperature class	T1	Ex equipment temperature class	from T1 to T6
	T2		from T2 to T6
	T3		from T3 to T6
	T4		from T4 to T6
	T5		T5 and T6
	T6		T6

Table 13: correspondence between the substance temperature class and the equipment temperature class

The electrical equipments of Group I are not divided in temperature classes but the maximum surface temperature must be always declared and must not overpass:

- 450°C where the coal dust is not expected to create a layer
- 150°C where the coal dust is expected to create a layer

5.2 - CLASSIFICATION OF ELECTRICAL EQUIPMENT FOR DUST ACCORDING TO IEC/EN 60079-0

The electrical equipments intended to be installed in presence of a “dust” potentially explosive atmosphere are classified in GROUP III and divided in subgroups, according to the classification of dusts as explained in chapter 2 and reported in table 14.

EQUIPMENT GROUP			
III	Electrical equipments intended for use in places with an explosive dust atmosphere other than mines with firedamp:		
	IIIA	IIIB	IIIC
	Combustible flyings	Non-conductive dusts	Conductive dusts

Table 14: classification of equipments as per IEC/EN 60079-0 - DUST

Also in this case, the same table shown for gases can be extended to Group III dusts:

Subgroups of combustible substances	IIIA	Subgroups of Ex equipment	IIIA, IIIB, IIIC
	IIIB		IIIB, IIIC
	IIIC		IIIC

Table 15: relation between substance groups and equipment groups

The combustible dusts are not classified in temperature classes as for the gases. Anyway it is always necessary to indicate in the marking the maximum surface temperature, distinguishing if in presence of a layer or not, as shown in Table 16.

MAXIMUM SURFACE TEMPERATURE	
Without a layer of dust	Ex. T 100°C
For a certain thickness of dust T_L in mm that surrounds all the sides of the equipment	Ex. T ₄₀₀ 140°C

Table 16: maximum surface temperature

5.3 – GENERAL REQUIREMENTS FOR ELECTRICAL EQUIPMENT

In IEC/EN 60079-0 standard there are paragraphs concerning some of the technical requirements that must be respected by the electrical equipment intended to be installed in potentially explosive atmosphere, in order to contribute to guarantee the prevention of the ignition.

Among others, there are the mechanical and thermal resistance of the electrical equipment (mainly the enclosure), the sealing of the gasket/cable entry (IP rating), the accumulation of electrostatic charge, the earthing, the technical characteristics of the materials used for the enclosure, etc.

In the following paragraphs, some of the essential requirements will be detailed directly referring to IEC/EN 60079-0 standard.

5.3.1 – THERMAL AND IMPACT RESISTANCE AND IP RATING

The standard prescribes that both for gas and dust the enclosures in metallic or non-metallic material with non-metallic gaskets must pass without any damage a cycle of tests evaluating thermal and mechanical resistance and IP rating.

These harsh laboratory tests guarantee the maintaining of the characteristics of the equipment in time, simulating the typical conditions of ageing of the materials.

For what concerns the cold and hot thermal resistance, the equipment must be tested at the maximum operating service +20K for 672h at 90% of humidity and for 24h at the minimum operating temperature -5/10 K.



Picture 21: example of conditioning in climatic chamber

Then, the mechanical resistance against impact is tested: the standard requires that the equipment (or better the enclosure) must resist at an impact generated by a weight of $1_{+0,01}^0$ kg (the head impactor must be made of tempered steel and with hemispheric form with 25 mm diameter) dropped vertically from an height, specified in Table 17 that defines the field of application of the equipment.

Drop height $h_{+0,01}^0$				EQUIPMENT GROUP
GROUP I		GROUP II or III		
HIGH	LOW	HIGH	LOW	RISK OF MECHANICAL DANGER
2 m	0,7 m	0,7 m	0,4 m	"Enclosures and external accessible parts of enclosures (different from the light-transmitting ones)" such as junction boxes, sockets, etc. "Guards, protective covers, fan hoods, cable glands"
0,7 m	0,4 m	0,4 m	0,2 m	"Light-transmitting parts without guards " such as glasses, displays and monitors
0,4 m	0,2 m	0,2 m	0,1 m	"Light-transmitting parts with guard having individual openings from 625 mm ² to 2 500 mm ² (tested without guard)" such as lighting fixture with cage

Table 17: drop height for impact test related to equipment type and risks

As shown in Table 17 there are two types of mechanical risk: it is the manufacturer who decides if the device must resist to a high or a low risk.

When the manufacturer declares the electrical equipment has been tested with low risk, it has to be marked with an "X" which identifies the specific condition of use.



Picture 22: impact test

After thermal and mechanical conditioning, the IP rating is tested, in compliance with IEC/EN 60529 standard to verify the resistance against the penetration of solid bodies or water as per Table 18.

IP RATING			
1 st digit of IP rating: solid bodies		2 nd digit of IP rating: water	
0	Non-protected	0	Non-protected
1	Protected against solid objects with dimensions >50mm	1	Protected against vertically dripping of water
2	Protected against solid objects with dimensions >12,5 mm	2	Protected against dripping of water (15° tilted)
3	Protected against solid objects with dimensions >2,5 mm	3	Protected against spraying of water
4	Protected against solid objects with dimensions >1 mm	4	Protected against splashing of water
5	Dust-protected	5	Protected against jetting of water
6	Dust-tight	6	Protected against powerful jetting of water
		7	Protected against temporary immersion
		8	Protected against continuous immersion

Table 18: IP protection degrees



Picture 23: IP test - DUST



Picture 24: IP test - WATER

5.3.2 – GASKET SEALING

Where the degree of protection provided by the enclosure depends on a gasketed joint which is intended to be opened for installation or maintenance, gaskets must be attached or secured to one of the mating faces to prevent loss, damage or incorrect assembly.

The gasket material other than not adhering to the other joint face must guarantee an operating temperature range compatible with the operating temperature of the device.



Picture 25: example of a gasket attached to a joint side

The adhesives or materials used for attaching the gasket to the joint side must have the same thermal characteristics of the gasket material and be compatible with the materials with which they are attached without damaging.

5.3.3 – RESISTANCE TO LIGHT

The resistance to light of enclosures, or parts of enclosures, of non-metallic materials must be satisfactory, as defined in IEC/EN 60079-0 standard. Materials meeting the ultraviolet light exposure requirements (f1) in ANSI/UL 746C are considered satisfactory and do not need any further test.

Where not otherwise protected from exposure to light, a resistance test of the material to ultraviolet light must be made if the enclosure or parts of the enclosure, upon which the type of protection depends, are made of non-metallic materials. The test is done on normalized-dimension bars.



Picture 26: examples of samples for testing the resistance to ultraviolet light

For Group I equipment, the test applies to luminaires only.

If the equipment is protected from light (for example, daylight or light from luminaires) when installed, and, in consequence, the test is not carried out, the equipment shall be marked by the symbol “X” to indicate this specific condition of use.

Sheet 5 resumes the situation of light requirements for enclosures in non-metallic material.

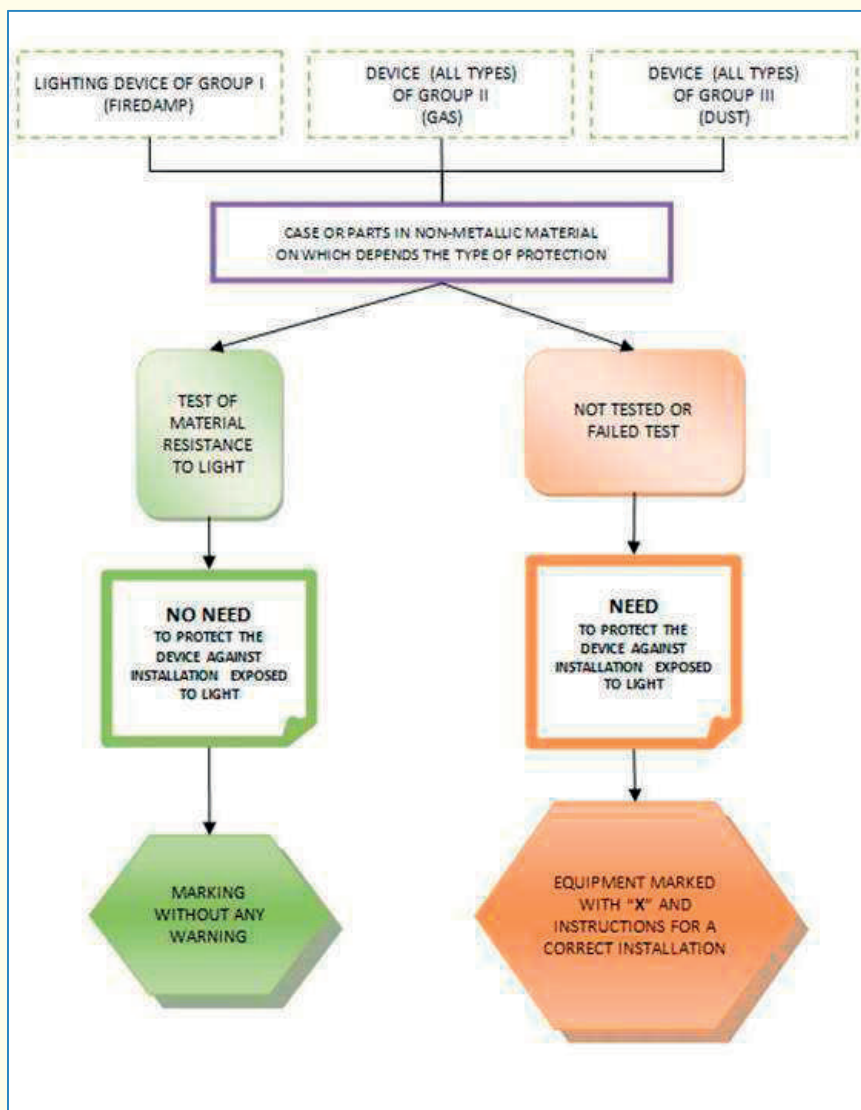

Sheet 5: light requirements for enclosures in non-metallic material

5.3.4 – ELECTROSTATIC CHARGES

One of the main requirements that an electrical device must respect is to avoid the ignition risk due to the presence of surface electrostatic charges.

This requirement must be satisfied by means of one of the following methods for products of Group I and II:

- by suitable selection of the material so that surface resistance complies with either of the limits given below:
 resistance of $\leq 10^9 \Omega$ (1 G Ω) measured at 50 ± 5 % relative humidity or
 $\leq 10^{11} \Omega$ measured at 30 ± 5 % relative humidity

- the limitation of surface of non-metallic material, according to group and zone and to Table 19. The surface is defined with the following method:
 - for sheet materials, the area is the exposed (chargeable) area
 - for curved objects, the area is the projection of the object giving the maximum area.

Maximum surface area [mm ²]				
GROUP I	GROUP II			
	Epl	IIA	IIB	IIC
10000	Ga	5000	2500	400
	Gb	10000	10000	2000
	Gc	10000	10000	2000

Table 19: Maximum surface of non-metallic parts according to group and zone

NB: the values for surface area can be increased by a factor of four if the exposed area of non-metallic material is surrounded by and in contact with conductive earthed frames. Alternatively, for long parts with non-metallic surfaces, such as tubes, bars, or ropes, the surface area needs not to be considered, but the diameters or widths shall not exceed the values shown in Table 20.

Maximum diameter or width [mm]				
GRUPPO I	GRUPPO II			
	Epl	IIA	IIB	IIC
30	Ga	3	3	1
	Gb	30	30	20
	Gc	30	30	20

Table 20: Maximum diameters or widths according to group and zone

- by limitation of a non-metallic layer bonded to a conductive surface, such as a layer of powder coating. The thickness of the non-metallic layer shall not exceed the values shown in Table 21.

Maximum thickness [mm]				
GROUP I	GROUP II			
	Epl	IIA	IIB	IIC
2	Ga	2	2	0,2
	Gb	2	2	0,2
	Gc	2	2	0,2

Table 21: Maximum thickness according to group and zone

- by provision of a conductive coating. The equipment must be marked "X" and the documentation must provide guidance on the use of the product.
- for fixed installations where the installation is intended to minimize the risk from electrostatic discharge, by marking the equipment "X". The instructions must provide guidance for the user to minimize the risk from electrostatic discharge.

For products of Group III this requirement can be satisfied by means of one of these solutions:

- by suitable selection of the material so that surface resistance complies with the limits given below:

resistance of $\leq 10^9\Omega$ (1 G Ω) measured at 50 ± 5 % relative humidity or $\leq 10^{11}\Omega$ measured at 30 ± 5 % relative humidity

- by a breakdown voltage ≤ 4 kV (measured across the thickness of the insulating material according to the method described in IEC 60243-1)
- by a thickness ≥ 8 mm of the external insulation on metal parts.

5.3.5 – CHARACTERISTICS OF PLASTIC AND ELASTOMERIC MATERIALS

The essential requirements that must be respected by non-metallic enclosures or parts of them, on which depends the type of protection, are fundamental.

The specification for plastic material must contain:

- name or trademark of the manufacturer
- identification of the material, type, color, eventual percentage of reinforcements, fillings or additives
- possible surface treatments such as varnishes
- the *Temperature Index* TI, corresponding to the 20.000h point on the thermal endurance graph without loss of flexural strength exceeding 50%, determined in accordance with IEC 60216-1 and IEC 60216-2 and based on the flexing property in accordance with ISO 178. As an alternative to the TI, the relative thermal index (RTI – mechanical) may be determined in accordance with ANSI/UL 746B
- when applicable information about resistance to UV rays.

The specification for the elastomeric material must contain:

- name or trademark of the manufacturer
- identification of the material, type, color, eventual percentage of reinforcements, fillings or additives
- possible surface treatments such as varnishes
- the *Continuous Operating Temperature (COT)*
- when applicable information about resistance to UV rays.

Chap.6: ATEX DIRECTIVES AND EX PRODUCT MARKING

In the previous chapter the main topic were the safety principles that are necessary to achieve in order to avoid the possibility of an explosion, which means to minimize the probability to create an explosive atmosphere and, at the same time, reduce the presence of potential ignition sources. In Europe there are two Directives issued to translate in a juridical way what said in the previous chapters, establishing *Essential Safety Requirements* (ESR) without giving any indication on how to achieve it.

The manufacturer, or generically those to which the Directives are addressed, is free to decide technical procedures to use in order to satisfy the compliance with ESR. He can invent or respect what the harmonised standards prescribe. As a matter of fact, the harmonised standards, such as IEC/EN 60079, are applicable to the Directive and guarantee the presumption of conformity. Harmonised standards are published on the Official Journal of the European Union (the OJ), directly from the European Commission.

6.1 - DIRECTIVE 99/92/EC

The Directive 99/92/EC, become effective on 1st July 2003, concerns worker health and safety when exposed to the risk of explosive atmospheres and, in this case, refers to EHSR (*Essential Health Safe Requirements*) rather than ESR.

The aim of the Directive is to assess the risk of an explosion, the technical measures used to minimize the formation of an explosive atmosphere and the probability of an ignition.

In order to achieve this, the Directive provides specific dispositions that must be complied in hazardous areas, both for gas and dust.

This becomes an operative obligation for the employer to classify his area and select suitable equipment for safe installation inside the same.

This reflects the *IEC zone system* explained in chapter 2; as a matter of fact, the European Commission established presumption of conformity with this Directive for the IEC/EN 60079-10-1 and IEC/EN 60079-10-2 harmonised standards.

The Directive provides in detail all the obligations for the employer to improve the worker health and safety; and some of them are:

- risk assessment document (based on the probability and duration of explosive atmospheres and ignitions, installation and process characteristics, substances which are present and used, predictable effects, assessment of non-hazardous areas connected to hazardous areas)
- subdivision in hazardous zones identifying for each one the safety minimum prescriptions (personnel training, giving detailed instructions about dangerous work operation, providing ways to release gas and dust toward safe areas, providing for workers suitable equipment to avoid electrostatic discharge, etc.).

- document about protection against explosions (done before the plant begins to work to locate and assess explosion risks, take preventions to satisfy the directive requirements, such as areas with safety minimum prescriptions, indicate work tools and areas designed as safe, etc.)

Moreover, the Directive 99/92/EC requires that the areas with possibility of explosion atmosphere must be identified with the proper triangular symbol, Picture 27.



Picture 27: signal that identifies areas with possibility of an explosive atmosphere

In order to avoid fines, workplaces with possibility of explosive atmospheres used for the first time (or transformed in hazardous places from non-hazardous) after 30th June 2003 must satisfy the Directive requirements **immediately**. Hazardous places already present and used before this day had 3 years in order to be in compliance with the new directive (within 30th June 2006, so **the time is over!**)

6.2 - DIRECTIVE 2014/34/EU

If the Directive 99/92/EC can be defined as social, since the aim is worker health and safety, by classifying hazardous areas in zones the Directive 2014/34/EU focuses more on the essential requirements that the equipment or protection systems must ensure in order to be installed in potentially explosive atmospheres.

The 2014/34/EU mainly addresses the manufacturers, importers and all those that place on the European Community market a product intended to be installed in explosive atmosphere.

As the Directive 99/92/EC provides Essential Safety Requirements attached to the text without giving any technical indications on the product.

This Directive:

- contains electrical and non-electrical products
- considers all the potential ignition sources
- subdivides equipment in groups and categories that guarantee the safety against ignition according to their functioning
- establishes conformity procedures that must be complied by the manufacturer according to the group and category danger (see chapter 7)
- contains the CE marking with visual symbol of the products which are in compliance (see following chapters).

Here below Table 22 helps to understand which are the application fields of the Directive.

DIRECTIVE 2014/34/EU APPLICATION	
YES	NO
Equipments: machines, materials, fixed and mobile devices, control devices, detecting tools and systems that, alone or combined, are intended for production, transport, storage, measurement, control and conversion of energy and transformation of material that can create an explosion caused by potential ignition sources	Medical devices for use in medical environment
Safety systems: safety, control and regulation devices intended to be used out of hazardous areas, but necessary or useful for the functioning of the above devices (Ex-i barriers)	Equipment with ignition risk due to explosive or unstable chemical materials
Protection systems: devices whose function is to prevent explosions and/or circumscribe the area where it occurred, placed on the market with autonomous functions	Equipment intended for use in domestic environments
Components: essential parts for the safe functioning of equipment and protection systems, with no autonomous function	Personal protective equipment
	Equipment used on board of seagoing vessels or offshore mobile units
	Means of transport

Table 22: directive 2014/34/EU application

6.2.1 – EQUIPMENT GROUPS AND CATEGORIES

The Directive 2014/34/EU divides the equipment in **groups** based on their use:

- **GROUP I:** equipment intended for use in mines with firedamp
- **GROUP II:** equipment intended for use in explosive atmosphere in surface.

As it can be inferred from the below Tables, 23 and 24, each group is subdivided in **categories**.

GROUP I		
CATEGORY	Protection level	Functioning conditions
M1	Very High Two means of protection Two faults	Energized in the event of an explosive atmosphere
M2	High Guaranteed in normal operation and in case of more severe operating conditions	De-energized in the event of an explosive atmosphere

Table 23: division in categories of equipment in group I

GROUP II				
CATEGORY	Protection level	Explosive atmosphere presence and duration	ZONE	
			GAS	DUST
1	Very High Two means of protection Two faults	Always, often of for long periods	0	20
2	High One mean of protection One fault	Probable	1	21
3	Normal Guaranteed in normal operation	Rare	2	22

Table 24: subdivision in categories of equipment in group II

To the category number it is necessary to add the letters G and D according to the presence of Gas or Dust (if both the letters are present, it means that the device is suitable for both gas and dust). As it can be inferred, there is a direct correspondence among Directive groups and categories and protection levels, and consequently hazardous areas.

EPL (harmonised standards) and GROUPS/CATEGORIES (directive) CORRESPONDENCE					
IEC/EN 60079			ATEX 2014/34/EU		
GROUP	ATMOSPHERE	EPL	PROTECTION LEVEL	GROUP AND CATEGORY	INSTALLATION ZONE
I	MINE FIREDAMP	Ma	VERY HIGH	I M1	/
		Mb	HIGH	I M2	/
II	GAS (IIA IIB IIC)	Ga	VERY HIGH	II 1G	Zone 0
		Gb	HIGH	II 2G	Zone 1
		Gc	NORMAL	II 3G	Zone 2
III	DUST (IIIA IIIB IIIC)	Da	VERY HIGH	II 1D	Zone 20
		Db	HIGH	II 2D	Zone 21
		Dc	NORMAL	II 3D	Zone 22

Table 25: correspondence between groups/categories and EPL

A category 1 equipment is suitable for all the hazardous zones, while it is not the same for category 2 and 3 which respect the following Table 26.

HAZARDOUS ZONES	EQUIPMENT CATEGORY
Zone 0 - 20	Category 1
Zone 1 - 21	Category 1 or Category 2
Zone 2 - 22	Category 1 or Category 2 or Category 3

Table 26: relation between the hazardous zone and equipment category that can be installed

It is important to underline that category 3 equipments, suitable to be installed in zone 2-22, are the most installed and represent around the 80% of those installed in ATEX areas.

6.3 - 2014/34/EU DIRECTIVE AND DIFFERENCES WITH 94/9/EC

The new ATEX Directive regarding equipment, named **2014/34/EU**, became effective on 30th March 2014.

It is substantially a recast, or a replacement of the Directive 94/9/EC that was abrogated on 20th April 2016.

The new Directive does not bring substantial changes if compared with technical specifications of 94/9/EC; the field of application and exclusions, the conformity assessment procedures and the subdivisions in groups and categories are the same.

The main difference with the old Directive is the increased evidence on the obligations of the economic operators, such as manufacturers, authorized representatives, importers and distributors; with the support of Table 27, we will see the most important ones:

Duties of economic operators according to Directive 2014/34/EU		
<i>Economic operator</i>	<i>Definition</i>	<i>Obligations</i>
Manufacturer	Any natural or legal person who manufactures a product or has a product designed or manufactured, and markets that product under his name or trade mark or uses it for his own purposes	<p>Design and manufacture in accordance with the essential health and safety requirements.</p> <p>Draw up the technical documentation and carry out the relevant conformity assessment procedure.</p> <p>Draw up an EU declaration of conformity and affix the CE marking.</p> <p>Keep the technical documentation and the EU declaration for 10 years after the product has been placed on the market.</p> <p>Ensure that procedures are in place for series production to remain in conformity with this Directive.</p> <p>Ensure that product which they have placed on the market bear a type, batch or serial number allowing their identification.</p> <p>Accompany the product with instructions and safety information in a language which can be easily understood by end-users.</p> <p>When realising that a product which they have placed on the market is not in conformity with the Directive, the necessary corrective measures must be taken, such as withdraw it or recall it.</p>
Authorised representative	Any natural or legal person established within the EU who has received a written mandate from a manufacturer to act on his behalf in relation to specified tasks	<p>It does not have to draw up the technical documentation.</p> <p>Perform the tasks specified in the mandate received from the manufacturer.</p> <p>Keep the EU declaration of conformity for 10 years after the product has been placed on the market.</p>

<p>Importer</p>	<p>Any natural or legal person established within the EU who places a product from a third country on the Union market</p>	<p>Place on the market only products in conformity, ensuring that the manufacturer has done the appropriate conformity assessment procedure and has drawn up the technical documentation. Ensure that the product bears the CE marking and is accompanied by the EU declaration of conformity. Indicate on the product their name, registered trade mark or, where it is not possible due to the dimensions, on the packaging. Ensure that the product is accompanied by instructions and safety information in a language which can be easily understood by end-users. Ensure that the storage or transport conditions do not jeopardise its compliance with the requirements. Keep a copy of the EU declaration of conformity for 10 years after the product has been placed on the market. If they realise that a product which they have placed on the market is not in conformity with the Directive, the necessary corrective measures must be taken, such as withdraw it or recall it. The Directive does consider as a Manufacturer who places a product on the market under his name, or trade mark, and has the same duties.</p>
<p>Distributor</p>	<p>Any natural or legal person in the supply chain, other than the manufacturer or the importer, who makes a product available on the market</p>	<p>Ensure that the product bears the CE marking, that is accompanied by the EU declaration of conformity, the safety instructions in a language which can be easily understood by end-users. Ensure that the storage or transport conditions do not jeopardise its compliance with the requirements. If they realise that a product which they have placed on the market is not in conformity with the Directive, the necessary corrective measures must be taken, such as withdraw it or recall it. The Directive does consider as a Manufacturer who places a product on the market under his name, or trade mark, and has the same duties.</p>

Table 27: obligations of economic operators according to the Directive 2014/34/UE

Moreover, with the new Directive, EC declarations of conformity and EC type test certificates change their name and become EU declarations of conformity and EU type test certificates.

Anyway, the certificates issued by a Notified Body according to the ATEX Directive 94/9/EC are still valid according to the new Directive, as the harmonised standards that guarantee the presumption of conformity to the directive remain the same.

Even though the new Directive has been formally effective since 30th March 2014, the important day is 20th April 2016. It is now compulsory to be in compliance with the new Directive, (unless eventual delays in the receipt of the Member States inside their National Rules).

6.4 – EX PRODUCT MARKING

Since the first half of the 90s inside the European Community the national barriers have been cancelled and the goods are free to move. In this field, all the products that satisfy the essential health and safety requirements defined in each applicable Directive must bear a mark that represents it.

6.4.1 – CE MARKING

The graphic symbol used is the *CE marking*, that must be present on all the EX products (except for the components, for which the marking is not compulsory), Picture 28.

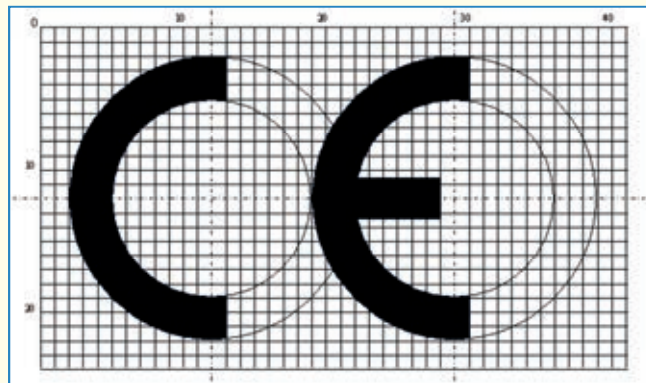

Picture 28: graphic symbol of the CE marking

The CE marking :

- is affixed on the product or on the label in a visible way, easy to read and indelibly. In case the dimensions of the product do not allow it, the marking must be affixed on the packaging and on the documents that accompany the product
- is affixed on the product before being placed on the market
- must be followed by the identification number of the Notified Body, when that body is involved in the production control phase
- in case of ATEX products, is accompanied by the specific mark of explosion protection, the symbols of group and category of the equipment
- the information above may be followed by other indications signalling a special use or risk.

6.4.2 – MARKING ACCORDING TO THE ATEX DIRECTIVE

As anticipated by the previous paragraph, the ATEX directive, other than the classic CE marking, requires the presence of a further graphic symbol represented by an hexagon with inside the letters *epsilon-x*, that must respect specific dimensions, Picture 29.

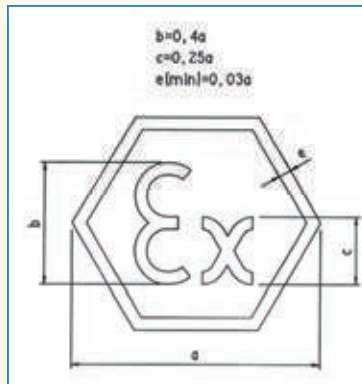

Picture 29: graphic symbol that identifies the EX products

The meaning of affixing a definite marking to an ATEX product is to communicate to those who buy, install or make any operation of maintenance or inspection, that the device satisfies the essential safety requirements of the Directive.

Said that, a product suitable to be installed in places with potentially explosive atmosphere can be in compliance with the ATEX Directive:

- because it is in compliance with the IEC/EN 60079 harmonised standards, that have presumption of conformity with the ESR of the Directive
- because it is in compliance with different laws and safety principles against the explosion, not mentioned inside the IEC/EN 60079 harmonised standards.

According to the above, there are two different types of marking: one prescribed by the Directive, that identifies the conformity, and another one that we can define as complete, containing all the indications relative to conformity with IEC/EN 60079 harmonised standards.

Marking according only to the Directive

The marking which satisfies only the requirements of the ATEX Directive must contain the following information:

- CE marking
- identification number of the Notified Body that assesses the Quality System of the ATEX production (for example 0051 is the identification number of IMQ)
N.B. this identification number is compulsory for those products where a Notified Body made the type examination (see Chapter 7), so for all the category 1 and 2 equipment
- the epsilon-x marking
- the equipment group and category followed by the letter D if for dust and G if for Gas

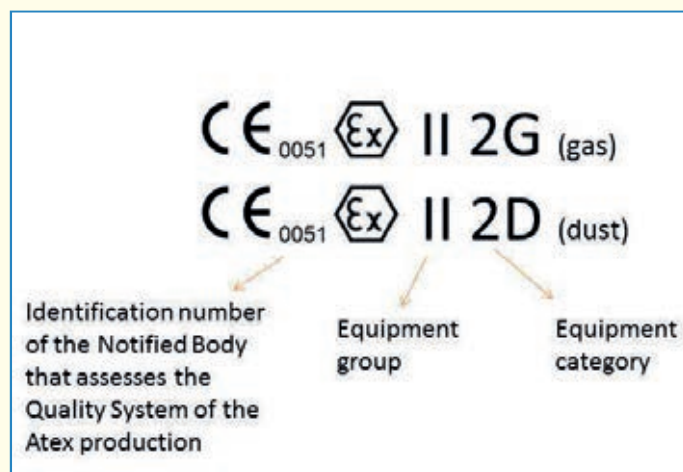

Sheet 6: example of marking according to the ATEX Directive – CATEGORY 1 and 2

For the category 3 equipment, since the Notified Body is not compulsory, the marking in compliance with the Directive can also be without the identification number (“0051” in the previous example).

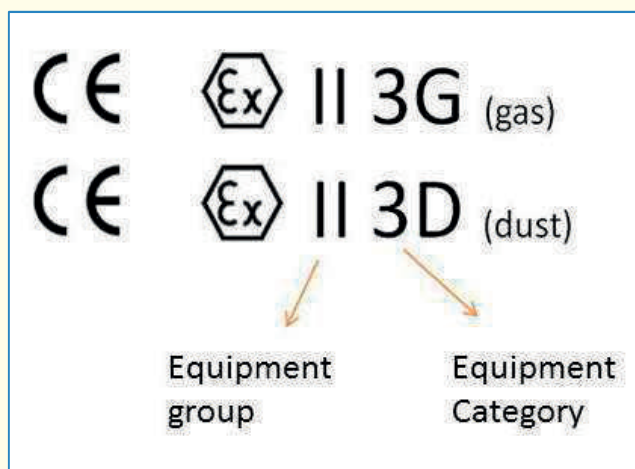

Sheet 7: example of marking according to the ATEX Directive – CATEGORY 3

Marking in compliance with the Directive and IEC/EN 60079 harmonised standards

On the contrary, if the conformity with the ATEX Directive is obtained through the conformity with IEC/EN 60079 harmonised standards (presumption of conformity with ESR of the Directive), the marking requires further information, contained in the Ex marking.

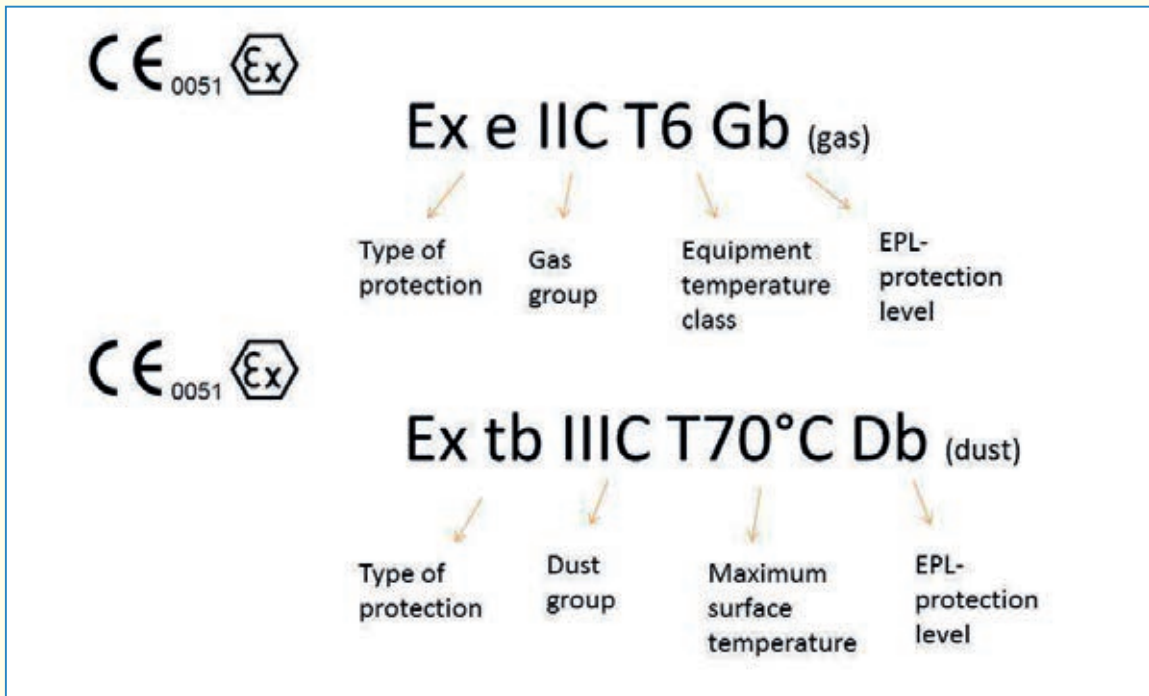

Sheet 8: example of marking in presumption of conformity with ATEX Directive because in compliance with IEC/EN 60079 harmonised standards

Anyway, the labels affixed on the ATEX products must contain also further information to identify unambiguously both the equipment and the manufacturer which is responsible for the same.

The needed data are:

- Name and address of the manufacturer
- Product part number
- Number of the EU/EC-type-examination certificate
- Batch identification number (serial number or week/year of production)
- Technical data that characterize the product (voltage, frequency, current, polarity, IP rating, insulation class, particular operating temperature, etc.)

Picture 30 shows in detail the marking of a Palazzoli interlocked socket, in which you can see the presence of all the needed information.

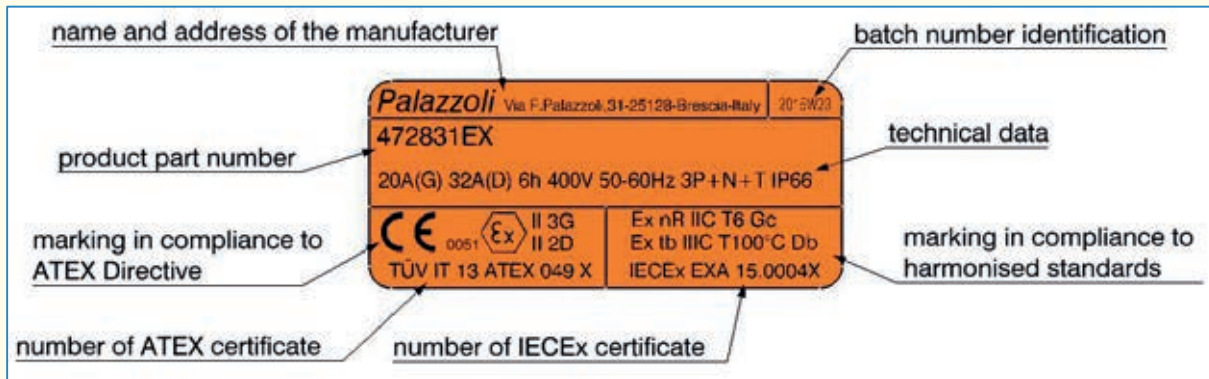

Picture 30: label example of a Palazzoli ATEX interlocked socket

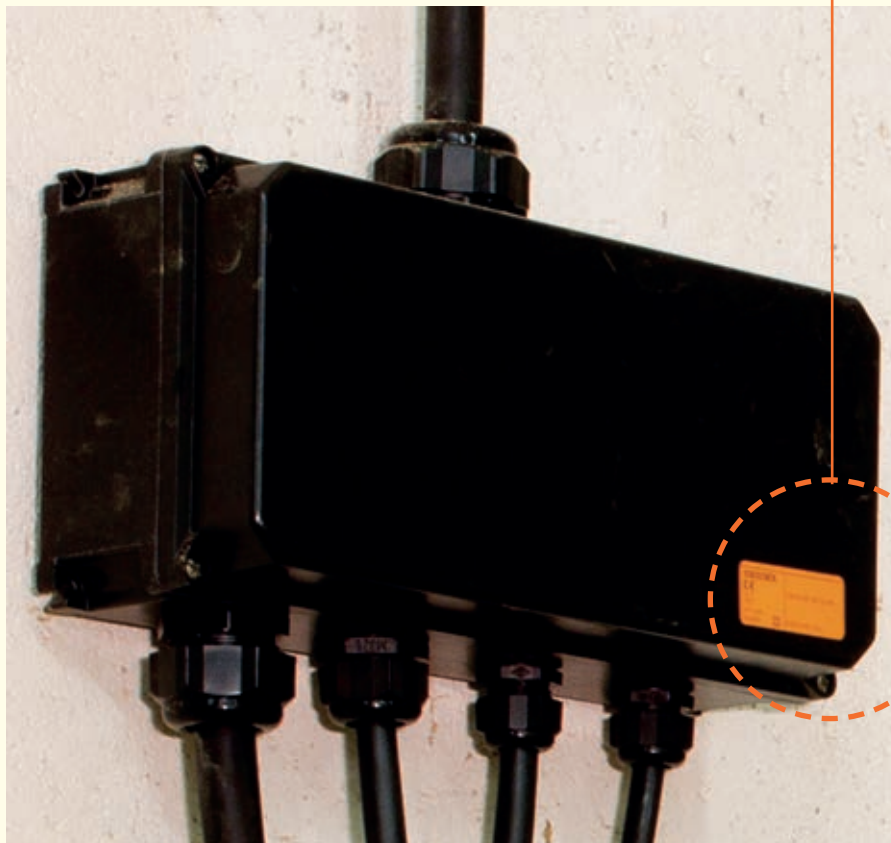



Cap.7: CERTIFICATIONS

As seen in the previous chapter, the ATEX Directive 2014/34/EU for the equipment provides the subdivision of Ex products in groups and categories, according to their suitability for the use in zones.

According to the category, the Directive prescribes different procedures for the *conformity assessment* of a product.

7.1 – CONFORMITY ASSESSMENT

For the equipment of **GROUP I CATEGORY M1** and **GROUP II CATEGORY 1 (G or D)**, it is necessary the certification by a third party, a Notified Body, for what concerns both the product conformity assessment and the production. The procedures are the following:

- The Notified Body must do the EU type examination and release the EU-type-examination certificate
- The Notified Body must certify the production quality system of the manufacturer for ATEX, releasing a notification, that is a sort of company certificate allowing the manufacturer to produce ATEX devices
- The manufacturer must guarantee the exact correspondence between the tested and certified prototype and each single piece produced. The test to assess the conformity of the prototype must be done by the Notified Body responsible of the certification, that releases a certificate of conformity
- At the end, the manufacturer draws up the EU declaration of conformity and affixes the CE marking on the product.

Also for the equipment of **GROUP I CATEGORY M2** and **GROUP II CATEGORY 2 (G or D)**, it is necessary to get the certification by a third party, a Notified Body, for what concerns both the product conformity assessment and the production. The procedures are the following:

- The Notified Body must do the EU type examination and release the EU-type-examination certificate
- The Notified Body must certify the production quality system of the manufacturer for ATEX, releasing a notification, that is a sort of company certificate allowing the manufacturer to produce ATEX devices
- The manufacturer must guarantee the exact correspondence between the tested and certified prototype and each single piece produced. The test to assess the conformity of the prototype must be done by the Notified Body responsible of the certification, that releases a certificate of conformity
- At the end, the manufacturer draws up the EU declaration of conformity and affixes the CE marking on the product.

It is different when we consider the equipment for **GROUP II CATEGORY 3 (G or D)**, intended for use in **ZONES 2-22**. As a matter of fact, this is the only case where the intervention of a Notified Body is not necessary. The procedures, in this case, are the following:

- the manufacturer performs an internal control on the device, guaranteeing autonomously that the production process is in compliance with the Directive requirements, making a **self-certification**
- the manufacturer can then proceed with the drawing up of an EU declaration of conformity and the affixing of the CE marking on the product.

Even though the equipments of **group II category 3** (suitable for zones 2-22) do not require the compulsory intervention of a third party, Palazzoli submits the conformity assessment also for these products to a Notified Body, applying the same procedure of the equipments with **group II category 2** (suitable for zone 1-21).

7.2 – THE TECHNICAL DOCUMENTATION

In this text the technical documentation has been mentioned many times. The aim of this paragraph is to clarify this aspect, clearly explaining which are the elements and information that must be present.

The technical datasheet explains the technical, functional and protection characteristics of the project in compliance with the essential safety requirements of the ATEX Directive and the relative conformity assessment procedure.

The aims are:

- placement and classification of the product for use suitable for the destination
- principles for the coding according to the ATEX directive
- a list of the standards, completely or partially applicable
- general description of the devices
- satisfaction of essential requirements of the ATEX Directive
- main technical information, design drawings and manufacturing of the product
- datasheet and/or trademark of the main used material
- descriptions and explanations to understand drawings and operation of the equipment
- ignition risk analysis of the equipment (normal and abnormal conditions according to the destination) with the description of the solutions used to satisfy the safety requirements of the ATEX Directive
- laboratory test reports
- CE marking and applied procedures for CE marking
- conformity marking for the reference standards of the specific type of protection
- copy of the conformity declaration

The most significant documents are the safety instructions, ignition risk analysis and conformity declaration.

7.2.1 – SAFETY INSTRUCTIONS, USE AND MAINTENANCE

The instructions for use are important because their correct application is the necessary condition to respect the essential safety requirements.

The instructions must be in the language of the end-users or in a language that can be easily understood and they must contain:

- each necessary indication to assess the conformity of the product for predictable use conditions
- technical parameters such as electrical, thermal, etc.
- essential characteristics of the parts that can be integrated in the products
- instructions for a safe placing in service, mounting and dismounting operations, installation and/or replacing of eventual components and maintenance
- legend for the indications reported on the markings.



Picture 31: example of a safety datasheet
CAM-EX isolator switch



Picture 32: example of a safety datasheet
TAIS-EX interlocked socket

7.2.2 – IGNITION RISK ANALYSIS DOCUMENT

Another important document is the one relative to the ignition risk analysis that the manufacturer prepares in order to show the conformity to the essential safety requirements of the Directive.

It contains a list of the standards completely or partially applied, harmonised and non, accompanied by the technical solutions used to satisfy the essential safety requirements.

It is a document with legal value, through which the manufacturer shows to the relevant Bodies (such as the Magistracy) to have correctly behaved for what concerns the design and manufacturing of the product.

In Picture 33 it is possible to find an extract of the document for the ignition risk analysis of a Palazzoli ATEX product.

		IGNITION RISK ANALYSIS						Brescia, 2014-02-08									
		Series RINO-EX						Technical datasheet N°414									
		FLUORESCENT ELECTRONIC WATERTIGHT LIGHTING FIXTURES						Attachment 8									
		TYPE OF PROTECTION Ex nA tb						Rev. 0									
								Page 6 of 11									
Ignition risk of the explosive atmosphere					Electrical ignition												
N.	Potential ignition source	assessment of the frequency in presence of a potential ignition source without additional measure				Motivation of the assessment	applied measures to avoid the ignition			Presence of the ignition source after the application of safety measures							
		Normal operation	Predictable fault	Rare fault	Not relevant		Applied measure	Reference: (technical standards, type test, ecc.)	Reference to technical documentation	Normal operation	Predictable fault	Rare fault	Not relevant	Protection level	Type of protection	Limitations	
4.1	Electrical spark in internal components	X				<p>Inside the enclosure of a standard Palazzoli fluorescent lighting fixture there are sparking components during normal operation.</p>	<p>The electronic power supply has been designed and tested from the manufacturer in order not spark.</p> <p>IP66 protection rating prevents the ingress of liquids and dusts, that could reduce the isolations and cause the sparking.</p> <p>The lighting fixture has been designed and tested against vibrations, to ensure that the components such as terminals and lampholders do not become sparking in presence of vibrations.</p> <p>The terminals are with spring or anti-loosening, in order to ensure that they do not spark during normal operation.</p>	EN 60079-15:2010,	<p>Technical datasheet n. 414-ATEX</p> <p>Safety instruction for use code C010167</p> <p>Test report RP2013-0342</p> <p>Power supply data sheet</p> <p>Statement of conformity with EN60079-15</p> <p>Terminals, lampholders datasheet</p>		X				Gc	Ex nA	IIC T4

Picture 33: example of ignition risk analysis document

7.2.3 – EU DECLARATION OF CONFORMITY

The EU declaration of conformity is the document that the manufacturer has to draw up to assess the conformity to the Directive and together with the safety, use and maintenance instructions they are the only documents which must accompany the product.

The EU declaration of conformity must contain:

- name or trademark of identification, accompanied by the address of the manufacturer
- a brief description of the device
- all the relevant dispositions that the equipment satisfies

- eventual name, number of identification and address of the Notified Body that makes the EU-type-examination and certifies the quality production, and the number of the EU-type-examination certificate
- identification of the signer who has the power to commit the Company (Manufacturer or a delegate inside European Community)
- eventual reference to harmonised standard and technical specifications used and other applied Community Directives.

Picture 34 shows an example of a declaration of conformity for a Palazzoli ATEX product.

		DICHIARAZIONE DI CONFORMITÀ UE EU DECLARATION OF CONFORMITY	
Il sottoscritto, Dr. Ing. Luigi Moretti, rappresentante il seguente costruttore The undersigned, Dr Ing. Luigi Moretti, representing the following manufacturer			
Palazzoli S.p.A. 25128 - BRESCIA - Italy - Via F. Palazzoli, 31 Tel. +39 30 2015.1 - Fax +39 30 2015.217 http://www.palazzoli.it - E-mail: palazzoli@palazzoli.it			
Dichiara, sotto la propria esclusiva responsabilità, che i prodotti: Hereby declare, under the own sole responsibility, that the products:			
PRESE INTERBLOCCATE in contenitore termoisolante serie TAIS-EX INTERLOCKED SOCKETS in thermosetting enclosure TAIS-EX series			
Con le seguenti principali caratteristiche / With the following main features:			
Descrizione / Description		Codice / Code	
Prese interbloccate in contenitore termoisolante Interlocked sockets in thermosetting enclosure		Vedi pagg. 2-3 delle Istruzioni di sicurezza rev. 04 (2018/12) See pages 2-3 of the Safety instruction rev. 04 (2018/12)	
CARATTERISTICHE TECNICHE / Technical Data			
Classe Isolamento / Insulating class: II			
Temperatura ambiente / Ambient Temperature range		Vedi pag. 4 delle Istruzioni di sicurezza rev. 04 (2018/12) See page 4 of the Safety instruction rev. 04 (2018/12)	
Grado di protezione (codice IP) / Degree of protection (IP code)		IP66	
Tensione nominale / Rated Voltage		750 V up to 500 V c.a. - 110/230/400/500V c.a.	
Corrente nominale / Rated Current		16 - 20 - 32 - 40 - 63 A	
Frequenze / Frequencies		50-60Hz (all types other than the models declared for hour reference 10h - tutte le versioni tranne quelle con riferimento orario 10h) 100-300 Hz (only for types declared for hour reference 10h - solo per modelli con riferimento orario 10h)	
Pole / Poles		3P+PE, 3P+PE, 3P+N+PE, 2P+T, 3P+T, 3P+N+T	
Soddisfa i Requisiti definiti dalle seguenti Direttive / Satisfies the Requirements defined by following Directives:			
2014/34/UE	ATEX		
2014/35/UE	LVD		
2014/30/UE	EMC (Only MCB versione / Solo versioni con Magnetotermico)		
2011/65/UE	RoHS / RoHS		
2012/19/UE	RAEE / WEEE		
and that the harmonized standards and/or technical specifications listed at the following page, have been applied. e che sono state applicate tutte le norme armonizzate e/o specifiche tecniche indicate nella pagina seguente.			
Marcatura dei prodotti / product marking			
			
Ex nR IIC TS/T6 Gc		Ex Ib IIC T 80° - 140°C Db	
II 3G 2D			
			
Ex Ib IIC T 115°C Db			
II 2D			
Ai sensi della Direttiva 2014/34/UE, l'apparecchiatura è oggetto del certificato di esame UE del tipo (allegato III) N.: According to Directive 2014/34/UE, above mentioned equipment is subject of EU-type examination certificate (annex III) N.:			
Prese singole Stand alone sockets	TÜV IT 13 ATEX 049 X.	emesso da / issued by: TÜV ITALIA S.r.l. Via Gioiub Carducci, 125 edificio 23 20099 Seato San Giovanni (MI) Organismo Notificato N. / Notified Body No.: 0948	
Product notification No: Notifica di prodotto N°:	IMQ 07 ATEXQ 001		
Notified body involved in the Production control stage: Organismo notificato designato al controllo della Produzione:	IMQ - via Quintiliano, 43 (MI) ITALY - N. 0051		
Brescia, 03/04/2017		Il Legale Rappresentante Palazzoli S.p.A. Presidente e C.D. (Dr. Ing. LUIGI MORETTI)	
1729			

Picture 34: example of a declaration of conformity

7.2.4 – EU-TYPE-EXAMINATION CERTIFICATE

As seen in the previous paragraphs, for the equipment of **GROUP I CATEGORY M1 and M2** and **GROUP II CATEGORY 1 and 2 (G or D)**, it is necessary the intervention of a Notified Body, both for the conformity assessment of the product and the production.

By the way, it is reported an analysis of a type-examination certificate in order to show how it is structured and which information it must contain:

Certificate number → TUV IT 14 ATEX 033

Manufacturer identification → Fabbrica Pirelli, S.p.A. (Pirelli & C. S.p.A.)

Applicable harmonised standards → EN 60529-2:2012, EN 60529-15:2011, EN 60076-31:2006

Marking → ENEC EX PAAC TB Di / ENEC EX PAAC TB Di

Certificate Content:

- 1) Equipment or Protective System:** 10 double lighting tubes with electronic ballast for fixed installation (RWO EX Series)
- 2) Manufacturer:** Fabbrica Pirelli, S.p.A. (Pirelli & C. S.p.A.)
- 3) Address:** Via Fabbrica Pirelli, 31 - 20120 Monza (MI) - ITALY
- 4) Description:** The equipment is protective system and any applicable variation limits as specified in the schedule in the certificate and the documents therein referred to.
- 5) Notified Body:** TÜV Italia, notified body no. 2000 in accordance with Article 9 of the Council Directive (Machinery) of 20 March 1988, certifies that the equipment or protective system has been found to comply with the Essential Health and Safety Requirements relating to the design and construction of equipment and protective systems intended for use in potentially explosive atmospheres given in Annex I to the Directive.
- 6) Examination and test results:** are recorded in confidential report no. 91461030.
- 7) Compliance:** with the Essential Health and Safety Requirements has been assessed to compliance with: EN 60529-2:2012, EN 60529-15:2011, EN 60076-31:2006
- 8) Scope:** The scope of the examination is limited to the design, examination and test results of the specified equipment or protective system. Examination does not include the production of the equipment or protective system. There are not covered by the certificate.
- 9) Marking:** The marking of the equipment or protective system shall be as follows:
 - E 30 Ex PAAC TB Di
 - E 30 Ex PAAC TB Di

Discretion date: 20th April 2014 - Suspension lasted till: 20th April 2014

Description of equipment → RWO-EX series luminaires for fluorescent T8 tubes in stainless steel or painted steel enclosure with glass diffuser and electronic ballast for use in hazardous area with risk of explosion.

List of codes in the certificate →

Code	Body material	Power	Effects	Temp
820131EX	Stainless steel	1x30W	Yes	20 ~ +50
820231EX	Stainless steel	1x30W	Yes	20 ~ +50
820331EX	Stainless steel	1x30W	Yes	20 ~ +50
820432EX	Stainless steel	2x30W	Yes	20 ~ +50
820532EX	Stainless steel	2x30W	Yes	20 ~ +50
820632EX	Stainless steel	2x30W	Yes	20 ~ +50
820731EX	Stainless steel	1x30W	No	20 ~ +50
820831EX	Stainless steel	1x30W	No	20 ~ +50
820931EX	Stainless steel	1x30W	No	20 ~ +50
821032EX	Stainless steel	2x30W	No	20 ~ +50
821132EX	Stainless steel	2x30W	No	20 ~ +50
821232EX	Stainless steel	2x30W	No	20 ~ +50
842131EX	Varnished steel	1x30W	Yes	20 ~ +50
842231EX	Varnished steel	1x30W	Yes	20 ~ +50
842331EX	Varnished steel	1x30W	Yes	20 ~ +50
842432EX	Varnished steel	2x30W	Yes	20 ~ +50
842532EX	Varnished steel	2x30W	Yes	20 ~ +50
842632EX	Varnished steel	2x30W	Yes	20 ~ +50
842731EX	Varnished steel	1x30W	No	20 ~ +50
842831EX	Varnished steel	1x30W	No	20 ~ +50
842931EX	Varnished steel	1x30W	No	20 ~ +50
843032EX	Varnished steel	2x30W	No	20 ~ +50
843132EX	Varnished steel	2x30W	No	20 ~ +50
843232EX	Varnished steel	2x30W	No	20 ~ +50

Rated characteristics table:

Material	ALUMIN 7 ALUMIN 5000 stainless steel, tempered glass
Maximum rated voltage	250 Vdc
Frequency	50/60 Hz
Inhalation class	I
Protection rating	IP66

CERTIFICAT • CERTIFICATE • CERTIFICADO • CERTIFICAT • CERTIFICATE • CERTIFICADO • CERTIFICAT

SCHEDULE

EC-TYPE EXAMINATION CERTIFICATE no. TUVV 144EX 031



Warning label

- WARNING - DO NOT OPEN WHEN AN EXPLOSIVE ATMOSPHERE MAY BE PRESENT
- WARNING - DO NOT OPEN WHEN ENERGIZED

Report no. R 144EX 031

Revision table

1. The manufacturer shall carry out the routine tests prescribed at par. 2.02.1 of EN 60950-1-0

Rev.	Description	Pages	Rev.	Date
001	Approved by TUV	1	01	04/03/2010
002	Approved by TUV	1	01	04/03/2010
003	Approved by TUV	1	01	04/03/2010
004	Approved by TUV	1	01	04/03/2010
005	Approved by TUV	1	01	04/03/2010
006	Approved by TUV	1	01	04/03/2010
007	Approved by TUV	1	01	04/03/2010
008	Approved by TUV	1	01	04/03/2010
009	Approved by TUV	1	01	04/03/2010
010	Approved by TUV	1	01	04/03/2010
011	Approved by TUV	1	01	04/03/2010
012	Approved by TUV	1	01	04/03/2010
013	Approved by TUV	1	01	04/03/2010
014	Approved by TUV	1	01	04/03/2010
015	Approved by TUV	1	01	04/03/2010
016	Approved by TUV	1	01	04/03/2010
017	Approved by TUV	1	01	04/03/2010
018	Approved by TUV	1	01	04/03/2010
019	Approved by TUV	1	01	04/03/2010
020	Approved by TUV	1	01	04/03/2010
021	Approved by TUV	1	01	04/03/2010
022	Approved by TUV	1	01	04/03/2010
023	Approved by TUV	1	01	04/03/2010
024	Approved by TUV	1	01	04/03/2010
025	Approved by TUV	1	01	04/03/2010
026	Approved by TUV	1	01	04/03/2010
027	Approved by TUV	1	01	04/03/2010
028	Approved by TUV	1	01	04/03/2010
029	Approved by TUV	1	01	04/03/2010
030	Approved by TUV	1	01	04/03/2010
031	Approved by TUV	1	01	04/03/2010
032	Approved by TUV	1	01	04/03/2010
033	Approved by TUV	1	01	04/03/2010
034	Approved by TUV	1	01	04/03/2010
035	Approved by TUV	1	01	04/03/2010
036	Approved by TUV	1	01	04/03/2010
037	Approved by TUV	1	01	04/03/2010
038	Approved by TUV	1	01	04/03/2010
039	Approved by TUV	1	01	04/03/2010
040	Approved by TUV	1	01	04/03/2010
041	Approved by TUV	1	01	04/03/2010
042	Approved by TUV	1	01	04/03/2010
043	Approved by TUV	1	01	04/03/2010
044	Approved by TUV	1	01	04/03/2010
045	Approved by TUV	1	01	04/03/2010
046	Approved by TUV	1	01	04/03/2010
047	Approved by TUV	1	01	04/03/2010
048	Approved by TUV	1	01	04/03/2010
049	Approved by TUV	1	01	04/03/2010
050	Approved by TUV	1	01	04/03/2010
051	Approved by TUV	1	01	04/03/2010
052	Approved by TUV	1	01	04/03/2010
053	Approved by TUV	1	01	04/03/2010
054	Approved by TUV	1	01	04/03/2010
055	Approved by TUV	1	01	04/03/2010
056	Approved by TUV	1	01	04/03/2010
057	Approved by TUV	1	01	04/03/2010
058	Approved by TUV	1	01	04/03/2010
059	Approved by TUV	1	01	04/03/2010
060	Approved by TUV	1	01	04/03/2010
061	Approved by TUV	1	01	04/03/2010
062	Approved by TUV	1	01	04/03/2010
063	Approved by TUV	1	01	04/03/2010
064	Approved by TUV	1	01	04/03/2010
065	Approved by TUV	1	01	04/03/2010
066	Approved by TUV	1	01	04/03/2010
067	Approved by TUV	1	01	04/03/2010
068	Approved by TUV	1	01	04/03/2010
069	Approved by TUV	1	01	04/03/2010
070	Approved by TUV	1	01	04/03/2010
071	Approved by TUV	1	01	04/03/2010
072	Approved by TUV	1	01	04/03/2010
073	Approved by TUV	1	01	04/03/2010
074	Approved by TUV	1	01	04/03/2010
075	Approved by TUV	1	01	04/03/2010
076	Approved by TUV	1	01	04/03/2010
077	Approved by TUV	1	01	04/03/2010
078	Approved by TUV	1	01	04/03/2010
079	Approved by TUV	1	01	04/03/2010
080	Approved by TUV	1	01	04/03/2010
081	Approved by TUV	1	01	04/03/2010
082	Approved by TUV	1	01	04/03/2010
083	Approved by TUV	1	01	04/03/2010
084	Approved by TUV	1	01	04/03/2010
085	Approved by TUV	1	01	04/03/2010
086	Approved by TUV	1	01	04/03/2010
087	Approved by TUV	1	01	04/03/2010
088	Approved by TUV	1	01	04/03/2010
089	Approved by TUV	1	01	04/03/2010
090	Approved by TUV	1	01	04/03/2010
091	Approved by TUV	1	01	04/03/2010
092	Approved by TUV	1	01	04/03/2010
093	Approved by TUV	1	01	04/03/2010
094	Approved by TUV	1	01	04/03/2010
095	Approved by TUV	1	01	04/03/2010
096	Approved by TUV	1	01	04/03/2010
097	Approved by TUV	1	01	04/03/2010
098	Approved by TUV	1	01	04/03/2010
099	Approved by TUV	1	01	04/03/2010
100	Approved by TUV	1	01	04/03/2010

The copy of all documents is kept in TUV data base.

Special consideration reference

None

Essential Health and Safety Requirements

Assessed by compliance with the standards set out in the [2].

This certificate may only be reproduced in its entirety and without any change, without the holder's consent.

page 3 of 5

Technical documents

Eventual special conditions of use

Sheet 9: type examination certificate analysis

Chap.8: ATEX vs IECEx

8.1 – THE IECEx SCHEME

If in Europe ATEX reference standards are the Community Directives, internationally, or more precisely out of Europe, all this is not enough.

As a matter of fact, in this case it is necessary to follow the IECEx scheme, which is the result of a multilateral agreement among Countries and Certification Bodies, based on the use and compliance with requirements of some international standards (IEC).



Picture 35: IEC and IECEx symbols

The IECEx scheme aim is to abolish the barriers among different Countries to facilitate the free movement of electrical equipments that can be installed in potentially explosive atmospheres and have one single scheme, recognized and valid at an international level, keeping an adequate safety level.

For this reason, the IECEx scheme provides that ACBs (*Accepted Certification Bodies* also said ExCBs) test and assess the conformity of electrical equipments used in explosive atmospheres by means of international standards about product safety, releasing certificates and test report recognized in the vast majority of the Countries in the world.

8.2 – DIFFERENCES BETWEEN ATEX DIRECTIVES AND IECEx SCHEME

Even though the devices are the same, there are some differences between ATEX Directives and IECEx international scheme that are important to be known.

In the following Table 28, some of the fundamental aspects of the IECEx scheme are mentioned, and for each of them, there is a comparison with what is prescribed by ATEX Directives.

ASPECT	IECEx	ATEX
Certification procedure	ExCBs emit: <ul style="list-style-type: none">• IECEx TR (test reports)• IECEx QAR (quality system assessment reports)• IECEx CoC (certificate of conformity). The certificates of conformity are officially registered in the IECEx website and can be completely seen by anyone.	The Notified Bodies emit the EU type certificates and notifications about the production quality (group I category M1 M2 and group II category 2)

<p>Conformity assessment</p>	<p>The procedure is the following: IECEX TR + IECEX QAR = IECEX CoC <i>IECEX TR</i>: document emitted by an ExTL (laboratory of an ExCB that performs tests according to the IECEX scheme) which contains a register of performed tests and shows that the examined product is in conformity with reference standards. <i>IECEX QAR</i>: document that presents the results of an assessment in place of the production quality system by an ExCB according to the IECEX scheme. The QAR is necessary for any type of products and self certifications are not allowed. A summary of the QAR is published on the official website of IECEX: www.iecex.com <i>IECEX CoC</i>: certificate of conformity assessing the conformity of the product with the specific reference standards. Also for CoC self certifications are not allowed for any type of products.</p>	<p>The manufacturer draws up the EU declaration of conformity through which he declares to have all the documents and test reports in conformity with the Directive. The Notified Body intervenes only for products of group I category M1 M2 and group II category 1 and 2. For the products in category 3 it is allowed a self-certification by the manufacturer, both for the production quality and the conformity of the product with the Directive.</p>
<p>Aim</p>	<p>One single certificate valid for each product that can be installed in potentially explosive atmospheres, recognized and considered valid at international level. Keep an adequate safety level. Reduce certification costs and times. One single international database.</p>	<p>Remove commercial barriers for products intended to be installed in potentially explosive atmospheres and improve equipment and worker safety.</p>
<p>Validity</p>	<p>The products certified according to the IECEX scheme are accepted in many Countries of the world.</p>	<p>The ATEX Directives are laws inside the Countries of the European Community and thus they are mostly accepted in Europe.</p>
<p>Field of application</p>	<p>Electrical and non-electrical products and systems. Places with explosion risk caused by Gas or combustible Dust. Also service industries.</p>	<p>Electrical and non-electrical products and systems. Places with explosion risk caused by Gas or combustible Dust. Only equipment.</p>

Reference standards	Only international standards, the conformity is compulsory.	Each accepted standard that can prove the compliance with essential safety requirements of the Directive. Anyway, EU approves a list of harmonised standards and the conformity with these standards guarantees also the compliance with the essential safety requirements: the compliance with these standards is not compulsory but they are almost always used to certify the products.
Manufacturer surveillance	The ExCB keeps the validity of the Coc according to the QAR.	Notified Bodies perform periodic controls of the manufacturers.
Workplace requirements	None, the references are to the standards of the different Member States.	The Directive 99/92/EC contains special necessities for what concerns the worker health and safety requirements.

Table 28: differences ATEX - IECEx

For what concerns the process of conformity assessment, the Sheet 10 can be used as a reference as it clarifies the single necessary steps to get an IECEx TR, IECEx QAR and IECEx CoC:

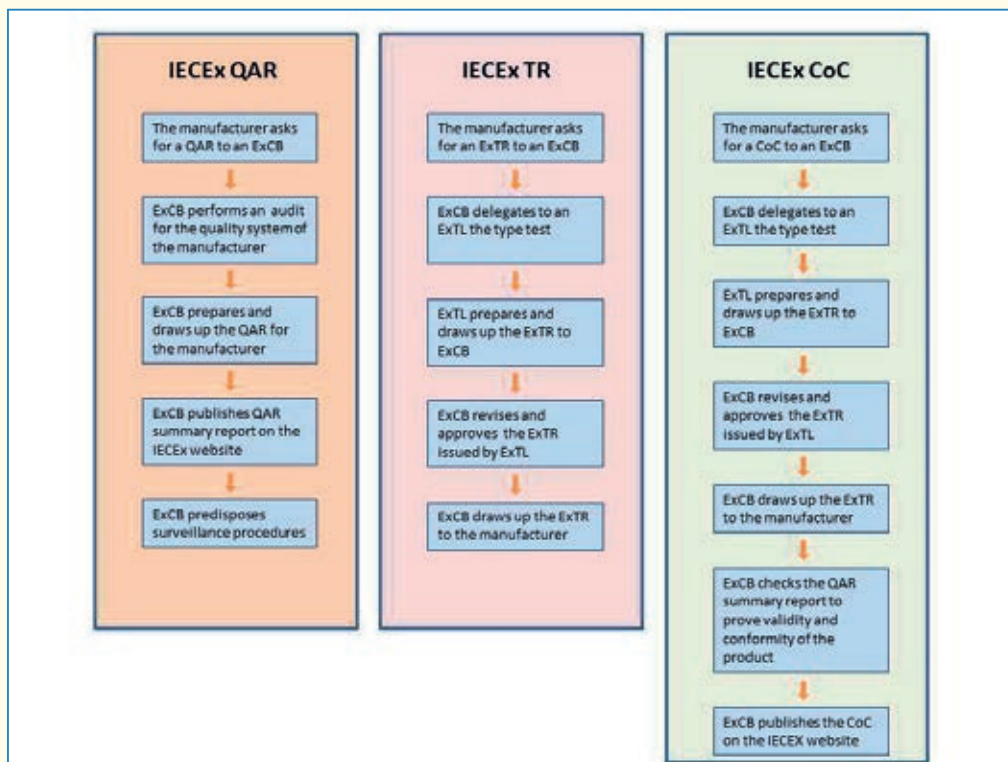

Sheet 10: necessary steps to get IECEx QAR, IECEx TR and IECEx CoC

8.3 – IECEX MARKING

For what concerns the IECEx marking, since the scheme does not provide any subdivision in groups and categories as the ATEX Directive, it refers to *Equipment Protection levels - EPL*.

As a matter of fact, the EPLs are enough to classify the products in terms of possible installation zones, as shown in Table 29, making the same function of groups and categories of the ATEX Directive.

EPL (harmonised standards) and GROUPS/CATEGORIES (directive) CORRESPONDENCE					
IEC 60079			ATEX 94/9/EC		
GROUP	ATMOSPHERE	EPL	PROTECTION LEVEL	GROUP AND CATEGORY	INSTALLATION ZONE
I	MINE FIREDAMP	Ma	VERY HIGH	I M1	/
		Mb	HIGH	I M2	/
II	GAS (IIA IIB IIC)	Ga	VERY HIGH	II 1G	Zone 0
		Gb	HIGH	II 2G	Zone 1
		Gc	NORMAL	II 3G	Zone 2
III	DUST (IIIA IIIB IIIC)	Da	VERY HIGH	II 1D	Zone 20
		Db	HIGH	II 2D	Zone 21
		Dc	NORMAL	II 3D	Zone 22

Table 29: groups/categories and EPL correspondence

For this reason, the marking according to the IECEx scheme is only of this type:

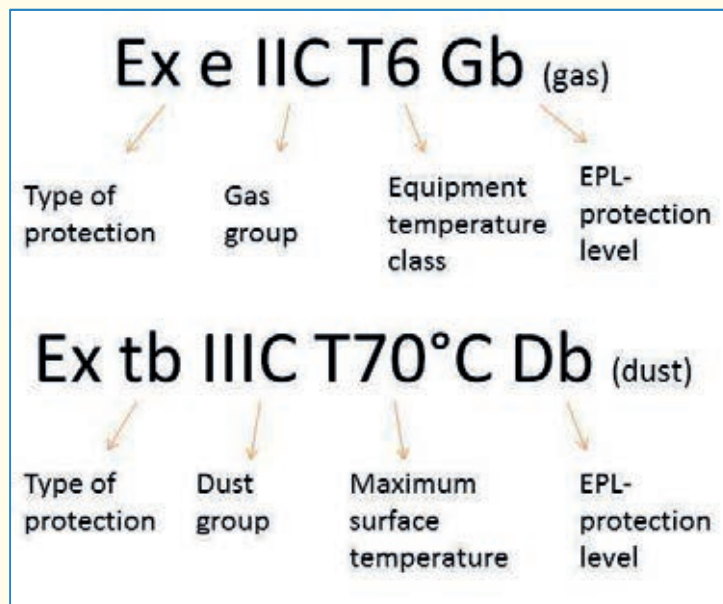

Sheet 11: example of marking in conformity with IECEx scheme

8.4 – WORLD MAP WITH ATEX-IECEX-OTHER SCHEMES

The IECEx international scheme is one of the most diffused in all the world.

According to statistics of 2012 there are 30 Countries that rely on and recognize this certification scheme, as shown in Table 30.

Countries which are part of the IECEx system		
Australia	Hungary	Romania
Brazil	Italy	Russia
Canada	India	Singapore
China	Japan	Slovenia
Croatia	Republic of Korea	South Africa
Czech Republic	Malaysia	Sweden
Denmark	Netherlands	Switzerland
Finland	Norway	Turkey
France	New Zealand	United Kingdom
Germany	Poland	USA

Table 30: list of Countries which recognize the IECEx scheme

Even though the vast majority of the Countries in the world recognize and accept the IECEx international scheme, some States tend to privilege specific certification schemes, as seen for example for the North-American States (Usa and Canada).

In order to clarify the concept, here below you can see a map of the world with the symbols of different certification schemes.



Picture 36: map of the world with different certification schemes

Chap.9: AREA CLASSIFICATION

9.1 - INTRODUCTION

Area classification: why?

The danger is present in each working activity, no exclusion. As a matter of fact, a research done in 2013 by the Italian National Institute of Statistics asserts that 714.000 people declared to have suffered an injury while they were at work or during the way home-work.

In the world ILO *International Labour Organization* showed in the press release of 28th April 2013 that 2.000.000 people died for accidents or sicknesses connected to their work.

Different national standards provide the indications that must be followed by the employer to reduce the danger in workplaces.

Among these dangers there is also the creation of an explosive atmosphere, so the area classification is a section of law to highlight the dangers that an explosive atmosphere could cause.

9.2 – HAZARDOUS AREA CLASSIFICATION PROCEDURE

Fixed the term “classification of areas” the question could be:

Classification of areas: which is the procedure to follow?

This is a typical procedure that can be followed:

- locate environment and relative conditions
- locate flammable substances or combustibles and their relevant characteristics
- locate sources of release (later indicated as SR) verifying the possibility to eliminate or limit them as much as possible
- establish for each SR the grade of release, verifying the possibility to reduce the load
- for each SR calculate the load of release in precautionary conditions
- for each SR establish the type of hazardous zone
- for each SR calculate the hazardous distance to define the shape of the dangerous volume
- classification of the hazardous area is obtained by the single hazardous zones.

9.2.1 – PROCEDURES TO CLASSIFY HAZARDOUS AREAS

It is important to specify that the classification does not depend only on the activity performed in that environment,

- for example: thermal plant = ZONE 2.

If it was so, it would have been useless to describe such a procedure, a table was enough; but the result at the end of the procedure does not necessarily cover the whole area but it could be that:

- one hazardous zone or no hazardous zone for all the environment
- one or more type of the same hazardous zone limited to one or more points of the environment
- more type of hazardous zones for different areas of the environment.

The conclusion is that an assessment must be performed for each environment.

At this point it is necessary to clarify that:

- provided that who is in charge of the procedure of classification must be an expert (a skilled person with knowledge of the relevant characteristic of the hazardous substances), to build an electrical plant is easy for skilled people, but it will be dangerous for those who do not have any knowledge about electricity
- there are environments (some of them will be introduced in the next paragraphs) for which the classification is simple and thus can be solved with few reasoning and data
- there are environments for which the production processes require a more complex reasoning and more data.

In the end, for each environment it is necessary to make a dedicated assessment.

9.3 – DEFINITIONS AND INFORMATION

For each environment that we will analyse there are terms which have common definitions; so, in order not to repeat them every time, here below there are some definitions of the main terms.

9.3.1 – EXPLOSIVE ATMOSPHERE

Mixture with air, in atmospheric conditions, of flammable substance in the form of gas, vapours, dusts, fibers or flyings that after the ignition allow the self sustaining of the flame propagation.

9.3.2 – SOURCE OF RELEASE

A source of release (later indicated as SR) is a point or part of the containment system from where a flammable substance/combustible can be released in air creating an explosive atmosphere. An SR can release either during normal operation and maintenance or in case of a fault.

9.3.3 – GRADE OF RELEASE

There are three fundamental grades of release.

Here below they are indicated in decreasing order of explosive atmosphere probability for the presence of gas:

- Continuous grade a release which is continuous or is expected to occur for long periods
- Primary grade a release which can be expected to occur periodically or occasionally during normal operation
- Secondary grade a release which is not expected to occur in normal operation and if it does occur, it is likely to do so only infrequently and for short periods

9.3.4 - DUSTS – LEVELS OF HOUSEKEEPING

An adequate housekeeping in places with presence of combustible dusts allows to exclude the presence of sources of release caused by dust layers.

The IEC/EN 60079-10-2 standard identifies three levels of housekeeping

LEVEL 1 – GOOD

The housekeeping is considered GOOD when dust layers are kept to negligible thickness, or are non-existent. In this case, the risk of the occurrence of explosive dust clouds from layers and the risk of fire due to layers have been removed.

LEVEL 2 – FAIR

The housekeeping is considered FAIR when dust layers are not negligible but are short-lived (less than one shift). The dust is removed before any fire can start.

LEVEL 3 – POOR

The housekeeping is considered POOR when dust layers are not negligible and persist for more than one shift. The fire risk may be significant, any conditions that can create a dust cloud (for example, someone entering the room) shall be considered in the hazardous area classification.

9.3.5 - ZONES

According to the frequency of formation and duration of explosive atmosphere for the presence of gas, hazardous areas are classified in zones.

This topic has been explained in chapter 3.

When beside the definition of ZONE the acronym NE (*negligible extension*) is added, it identifies a theoretical zone where, under specific conditions, the extension can be ignored.

9.4 – GARAGES



9.4.1 – LOCATE THE ENVIRONMENT

To locate the environment we can refer to the definition indicated by the standards for the fire prevention.

Garages: covered area dedicated to shelter, parking and movement of vehicles provided with related services. There are some spaces which are not considered car parks, such as areas covered with roof, open on at least two sides, those where each car place is accessible directly from places in open air, and spaces dedicated to exhibition or sale if the vehicles are without fuel or with limited fuel only for movement inside the exhibition area. They can be public or private.

From this definition we can deduce some useful information:

- the garage is a closed space, the natural ventilation is less than the open air; the ventilation influences the capacity to disperse the gas in the atmosphere
- a public garage is often open air, as to say without any separating element of the internal spaces, even this influences the evaluation of the ventilation
- a showroom where car are exposed with a limited amount of fuel is not hazardous.

Moreover, for the fire prevention standards the area dimensions are important for the following reasons:

- garages, public or private, with a surface up to 300 m² are not subject to fire prevention control

As we will see in paragraph 9.4.3 this does not influence the classification.

9.4.2 – FLAMMABLE SUBSTANCE

In a garage the flammable substances are the fuels present in the vehicle tanks. The standards particularly consider the following substances:

- gasoline
- liquefied petroleum gas (LPG)
- compressed natural gas (CNG)

Area classification: and the diesel?

The diesel is a flammable substance whose flash point is at more than 65 °C.

The flash point of the substances above listed is under 0 °C.

To have an explosive atmosphere with diesel the ambient temperature should be more than 65 °C which is not considered normal. A particular situation that could make diesel dangerous is the possibility that this substance is vaporized in the environment; but again this is not considered a normal situation in a garage.

9.4.3 – SOURCES OF RELEASE

In a garage the sources of release are present in case of anomalies that involve the release of fuel from a tank.

Regarding LPG

- 1. The parking of vehicles, fueled by liquefied petroleum gas, equipped with safety system in compliance with ECE/ONU 67-01 standard is allowed in floors over the ground and in the first floor under, even though they have more than one.*

Practically the LPG system in compliance with ECE/ONU 67-01 standard is considered a system with negligible release, so now the parking is allowed even where it was forbidden in the past.

Regarding CNG

Even in this case the release is considered negligible, the eventual outgoing of gas is considered a catastrophic fault (CNG is stocked in tanks with pressure of 200 bar).

The cases identified as “catastrophic fault” are not included in the classification procedure of the hazardous area as it would establish zones with huge width according to the event considered highly improbable.

Regarding Gasoline

Anomalies considered:

- it could be assumed that a fuel delivery tube breaks, is pierced or detaches from its place and consequently the liquid can outflow. If the vehicle was moving, the fuel would keep outflowing

till the noticing of the problem; if the vehicle was still, the outflowing would be limited to the liquid contained in the tube

- it could be assumed that the tank breaks, for example for a small crack; anyway this would happen after a violent choke that the driver could not ignore and consequently it would be immediately noticed and neutralized.

Assuming the formation of a puddle caused by the breaking of the fuel delivery tube, the most likely source of release is the surface of the liquid. In this situation, based on careful assessments, the quantity of fuel dispersed could be about 0,05dm³.

Taking the final part of the paragraph 9.4.1 (regarding the fire prevention), the source of release is an unexpected fact that can happen to any vehicle. For this reason, the area of the garage influences only the risk analysis: more vehicles mean higher probability that the unexpected event happens.

9.4.4 – GRADES OF RELEASE

Base on the definitions given in 9.3.3, the SR that can be present in a garage are classified as SECONDARY GRADE.

9.4.5 – LOAD OF RELEASE

The load of a puddle depends on different factors:

- the puddle surface
- the speed of ambient air and the efficiency factor of the ventilation
- the molar mass and pressure value of the flammable substance
- the atmospheric pressure
- and other different elements

If we consider the release of gasoline, based on the evaluations done by skilled people, we can estimate a load of release of about 0,005 mg/s. With this load, the gasoline concentration in air is so little that it can be considered negligible.

9.4.6 – TYPE OF ZONE

Based on the definitions of the chapter 3 the SR in a garage can determine a ZONE 2. Anyway, considering these values:

- the load of release
- the load of ventilation in environment close to the SR
- the air change in the environment and close to the SR
- the hypothetical volume of the explosive atmosphere and concentration in air

the ZONE 2 can be downgraded to ZONE 2 NE, as to say a theoretical zone where, with the specific conditions, the extension is negligible.

9.4.7 – HAZARDOUS DISTANCE

If the extension is negligible the hazardous distance is negligible.

9.4.8 – HAZARDOUS AREA CLASSIFICATION

Analysed the points of the previous paragraphs it is now possible to make an area classification. In the garage described at 9.4.1, the considered SR considered determine a ZONE 2 NE and, as the conditions declared by the employer are the same, the extension is negligible. Practically, there is no danger of explosion as the eventual explosive atmosphere has a limited extension. There is anyway the major risk in case of fire because of the high number of vehicles.

9.5 – CAR REPAIR SHOPS



9.5.1 - LOCATE THE ENVIRONMENT

Car repair shops can be divided in two categories:

- category A: car repair shops where there are not activities on the fuel, no hot working and no underground pit; for example a car electrical repair shop, a shop of an installer of burglar alarm or some particular sound systems, the tire repair shop, etc.
- category B: car repair shop where there are activities on the fuel, hot workings (welding or working on the vehicle components that can be a source of ignition) or underground pits.

In order to assess the explosion danger, in this chapter we exclude:

- the car body repair shops with painting departments
- the car repair shop specialized in vehicles with LPG or CNG, where there are activities on the high pressure system with full tanks and where it is allowed the access to vehicles with visible breaks on the high pressure system.

9.5.2 – FLAMMABLE SUBSTANCES

In a car repair shop the flammable substances are the fuels present in the vehicle tanks. The standards particularly consider the following substances:

- gasoline
- liquefied petroleum gas (LPG)
- compressed natural gas (CNG)

9.5.3 – SOURCES OF RELEASE

In the examined car repair shops the sources of release are either during normal operation or in case of anomalies that involve outflowing of fuel from the containment system.

LPG and CNG releases are not considered for the same reason of the previous chapter.

Sources of release during normal operation can be:

- washing of mechanical parts using flammable substances (this procedure is used less and less preferring products with a similar efficiency but non-flammable)
- inspections and test of the injectors or the circuit of fuel delivery when this involves a controlled outflowing
- tank emptying operations
- battery recharging

Sources of release caused by anomalies:

- it could be assumed that a fuel delivery tube breaks, is pierced or detaches from its place and consequently the liquid can outflow. If the vehicle was moving, the fuel would keep outflowing till the noticing of the problem. If the vehicle was still, the outflowing would be limited to the liquid contained in the tube
- another anomaly could be that a clumsy movement of the mechanic could cause the outflowing of the flammable substance.

9.5.4 – GRADES OF RELEASE

Based on the definitions of the paragraph 9.3.3 the SR that can be found in a car repair shop can be classified as PRIMARY and SECONDARY GRADE.

9.5.5 – LOAD OF RELEASE

Differently from the previous case – garages – it is not possible to establish a generic load of release, since the cases when the fuel can be out of the containment system are different, and the same for the ambient conditions. In these cases it is needed to make a punctual calculation, which is not possible here.

9.5.6 – TYPE OF ZONE

In the car repair shops of category A the ZONE 2 can be downgraded to ZONE 2 NE, as to say in a theoretical zone where the extension is negligible. The recommendations are:

- carefully avoid the release of flammable substances
- immediately remove eventual gasoline puddle to reduce the duration, for example by means of sand or neutralising substances.

In the car repair shops of category B in order to eliminate or reduce the extension of ZONE 1, eventually reducing them to ZONE 2 or ZONE 2 NE, the recommendations are:

- use of skilled personnel in all the operations that involve fuel: tank emptying, inspections of injectors, washing of mechanical parts

- tank emptying operations in circumscribed areas of the shop
- testing of the injectors using dedicated benches designed in order not to disperse the fuel
- washing of mechanical parts using dedicated pools with an opening lid and placed under a correctly dimensioned extraction equipment; moreover the position of the pool must be far from sources of heat, arcs and sparks
- eventual battery rechargers must be placed in a well ventilated area and the position must be far from sources of heat, arcs and sparks
- the operations that specifically interest the high pressure circuits of the vehicles with LPG or CNG must be with empty tanks and closed intercept valves.

9.5.7 – HAZARDOUS DISTANCE

Neither for the hazardous distance, as for the load of release, it is possible to give a generic dimension, so we refer to the results produced by who classifies the area. Assuming to dedicate precise dedicated working areas of the shop, it will be probably confined inside these areas; it will unlikely involve the whole shop.

9.5.8 – HAZARDOUS AREA CLASSIFICATION

Resuming the previous paragraphs:

- In the areas where the vehicles are parked to be repaired (excluding the fuel delivery circuit, tank included) the danger is the outflowing for an anomaly of the containers; considering the continuous presence of skilled people and the immediate remove of puddles, we configure a ZONE 2 NE.
- In the areas where dedicated machines are used as for example: test benches for injectors, pools with lid and extraction for washing mechanical parts and tools, we assume that there are releases only in case of anomalies; so, in this case, we can configure a ZONE 2.
- In the areas where there are activities like tank emptying, in specific cases, we can configure a ZONE 1.
- In the areas intended for battery recharging, generally not more than one meter in all directions starting from the cells of the accumulators, we configure a ZONE 1.

9.6 – NATURAL GAS THERMAL PLANTS



9.6.1 – LOCATE THE ENVIRONMENT

For this classification we assume the following entry data:

- room over the ground exclusively dedicated for thermal plant
- the thermal plant uses natural gas as combustible
- the operation rated pressure is between 20 mbar and 500 mbar
- aeration openings realized and placed in order to avoid the formation of gas locks
- the room is equipped with two openings, each with a surface of 1500 cm² (60x25 cm) for a total of 3000 cm²
- the activities in the thermal plant are performed by people properly skilled about explosive atmosphere risk, ignition sources and means of prevention and protection.

9.6.2 – FLAMMABLE SUBSTANCES

The flammable substance present in the examined thermal plant is:

- natural gas

The natural gas is a substance lighter than air (even if a little) and thus we would expect a dispersion towards above.

9.6.3 – SOURCES OF RELEASE

In a natural gas thermal plant the sources of release are present only in case of anomalies and are identified in discontinuity points of the pipes with insertion of connecting devices (flanges, joints, couplers and others) or control elements (valves, manometers, pressure switches and others):

- Flanges with fiber gaskets: assuming the collapsing of the sealing or the breaking of a flange gasket, there would be the outflowing of natural gas
- Valves: assuming the collapsing of the sealing or the breaking of a flange gasket, there would be the outflowing of natural gas.

The way of release, in this case, consists in dispersion of the flammable substance in air.

9.6.4 – GRADE OF RELEASE

Based on the definitions of the paragraph 9.3.3 the SR that can be found can cause a SECONDARY GRADE release.

9.6.5 – LOAD OF RELEASE

The load of release from a hole that can be accidentally created on a sealing device depends on:

- the hole surface
- the molar mass and pressure value of the flammable substance
- the atmospheric pressure and pressure inside pipes
- and other different elements.

Generally we could expect a load of release of:

- about 0,01 g/s flanges with gasket different from the compressed fibers
- about 0,1 g/s flanges with gasket in compressed fibers.

With the load of 10 mg/s there would be a negligible volume of explosive atmosphere; while with the load of 100 mg/s the volume must be considered.

9.6.6 – TYPE OF ZONE

Based on the definition of ZONE reported in chapter 3 the SR determine a ZONE 2; as a matter of fact, they are predictable releases only in case of fault or anomalies.

Considering the following parameters:

- load of release
- load of ventilation in the environment and close to SR
- air change in the environment and close to SR
- hypothetical volume of the explosive atmosphere and concentration in air, the situation could change.

Generally:

- in case of release from a flange gasket in compressed fibers the ZONE 2 is confirmed
- in case of release from a flange gasket different from the compressed fibers (for example the spiral wound or in Teflon or with metal ring on metal) the ZONE 2 can be downgraded to ZONE 2 NE.

9.6.7 – HAZARDOUS DISTANCE

If the extension is negligible, the hazardous distance is about 50 cm.

It is a rounded value to give an idea of the dimension, the correct value must be calculated with a punctual analysis of each case.

9.6.8 – HAZARDOUS AREA CLASSIFICATION

After having examined the points of the previous chapters, it is now possible to make a classification.

In the thermal plant with pipes jointed with flanges with a gasket in compressed fibers, the examined SR determine a ZONE 2 that extends from the SR for 0,5 m in all the directions. Different values can bring to different results.

9.7 - CARPENTRIES



9.7.1 - LOCATE THE ENVIRONMENT

They are places for the wood working – cutting, milling, planing, and drilling – with machine tools equipped with extraction fans. Also small repairing works that do not involve big quantities of saw dust are included in this activity.

In those installations where there can be dusts able to create an explosive mixture, there must be dedicated systems of extraction for each type of gas, vapour or dust, or some other measures must be taken to avoid the danger of explosion.

The machine tools can be reciprocating saws with horizontal movement, band saws, circular saws with swinging table or similar, planing machines, surfacers, millers.

Specific case for the example:

To simulate a specific case we assume the following data:

- in the carpentry three air changes are ensured every hour
- the fire prevention standards are respected
- the flammable substances are those indicated in the next paragraph.

9.7.2 - FLAMMABLE SUBSTANCES

In a carpentry the main element of working is wood and it is natural to think about this material as the only combustible substance; but in many carpentries there is a painting department and an area where glues are used.

In this example, we will focus only on wood.

The process of woodworking creates the following rejects:

- sawdust and woodchips, as to say particles that cannot be defined as combustible dust
- dust with particles bigger than 500 μm (as to say 0,5 mm); these rejects are partially not removed by the extraction system and deposit on the floor, machines and installation.
- dust with particles smaller than 0,5 mm, same as above.

According to the definition of the technical standard, the combustible dust is made of solid particles with dimensions equal to or smaller than 0,5 mm.

Some working – particularly during finishing operations – produces particles that can be defined dust.

But the problems are more, because according to the type of tree (pear tree, walnut, beech and others) the characteristics of wood do change.

Characteristics of the beech sawdust (approximate, there are no absolute values):

- Lower explosion level 40 g/m^3
- Ignition temperature for a layer of 5 mm 310 $^{\circ}\text{C}$
- Ignition temperature of the cloud 490 $^{\circ}\text{C}$
- Maximum overpressure of explosion 9 bar
- Limit concentration of oxygen.....5%
- Minimum ignition energy.....30 mJ

Other needed data for the classification depend on the type of working and state of the dust, so for the example we assume:

- a dimension of less than 0,5 mm as a medium size
- a volume unit mass of 1000 kg/m^3 . The volume unit mass is the volume in a cubic meter which is occupied by compact particles without considering internal vacuoles and is measured in kg/m^3 . The beech, as the black locust, sessile oak, cherry-tree has a specific weight of 1 ton for cubic meter
- humidity present in the dust equal to 3,5%

In order to have precise values, when needed, you must ask to a specialized laboratory.

9.7.3 – SOURCES OF RELEASE

The source of release is a point from which the dust can be released or raised (if it is a layer) creating an explosive atmosphere. In a carpentry there can be:

- layers of combustible dust in open containers
- layers of dust deposited out of containers (on the floor or machines) that can be frequently disturbed
- opening towards the environment of machines that produce combustible dusts
- bag emptying points and/or small containers
- not hermetically sealed bags
- discontinuity points of machines and pipes.

9.7.4 – GRADE OF RELEASE

Based on the definitions of the paragraph 9.3.3 the SR that can be found can cause FIRST and SECONDARY GRADE release.

9.7.5 – LOAD OF RELEASE

Neither in this case is it possible to establish a generic load of release, as the cases in which the dust can be out of the containment systems are different so as the ambient conditions. In these cases you must proceed each time with a punctual calculation, which is not possible here.

9.7.6 – TYPE OF ZONE

As indicated in chapter 3 there are three types of zone: ZONE 20; ZONE 21; ZONE 22.

Zone 20

Generally there is a ZONE 20 inside the containment systems in which a part of the dust contained stays suspended in air, for example:

- inside the extraction line system (ducts)
- in the surroundings of the tools that during all the working day treat wood, producing small particles of dust (such as the polishing or sizing machines) without an adequate extraction system.

In this second case, we specify that in working areas the presence of ZONE 20 – continuous presence of dust that would be breathed by the operator – is forbidden and thus this eventuality is not considered.

One of the ignition dangers in ZONE 20 is the movement of dust, inside transport systems, with speed higher than 1 m/s; in these cases there is an accumulation of electrostatic charge (ex. pneumatic conveying of dust).

Zone 21

It is a ZONE 21 when:

- conditions are similar to those of the second example of the previous paragraph of ZONE 20, but for a short period of the working day. Also in this case the main measure to take is an adequate extraction system
- caused by a wood dust cloud that is formed emptying the sacks of the extractors combined with machines producing tiny particles.

Zone 22

It is a ZONE 22 each time it is possible to disperse the dust in air caused by an anomaly or a distraction of the operator, for example:

- extraction system out of use for a fault; from the moment of the fault to its individuation

and block of the production there will be a short period in which an explosive atmosphere can occur

- in many cases the extraction system brings the dust in bags that, once full, are emptied manually. During this operation one of the bags can slip through the hands of the operator and fall, break or other and, consequently, be dispersed in air. For a short period the dust can create an explosive atmosphere
- the breaking of a connecting duct made of textile material – they are couplers between tubes or between tubes and extraction system devices – could cause that the contained dust goes out and creates an explosive atmosphere
- the deposited dust accidentally raised from the ground – for example using compressed air – and mixed with air could create an explosive atmosphere

9.7.7 – HAZARDOUS DISTANCE

The cases in which the dust can be dispersed in air are very different and it is not possible to estimate a size. For this reason, the reference in such case will be the results produced by who classifies the area.

9.7.8 – HAZARDOUS AREA CLASSIFICATION

Resuming the previous paragraphs:

- considering the presence of an adequate extraction system or the presence of closed machines to reduce at minimum the dispersion of dust, ZONE 20 and 21 are considered unlikely in a carpentry
- considering cases of anomalies, the cleaning frequency (removing the dust from the surfaces, not only the floor) in the working areas, the probability of ZONE 22 is not negligible.

9.8 – AGRICULTURAL INDUSTRIES



9.8.1 – LOCATE THE ENVIRONMENT

In this paragraph we will analyse the industries of the primary sector, those that deal with cereals, legumes, peanuts, cocoa, coffee, sugar and other agricultural products.

In these places, during the movement and deposit of the above mentioned products, clouds are created; as to say, tiny particles with dimensions equal to or less than 0,5 mm.

Same as explained in the previous chapter for carpentries, places where there can be dusts able to create an explosive atmosphere must be equipped with extraction systems.

9.8.2 – FLAMMABLE SUBSTANCES

The dust created by cereals, legumes, peanuts, cocoa, coffee, sugar and other agricultural products, if mixed with air creates an explosive atmosphere.

In the following table there are quoted some values of these elements: the listed substances present very different characteristics; the minimum ignition energy of rice is 5 mJ, while for cocoa is 20.000 times higher.

	<i>Rice</i>	<i>Sugar</i>	<i>Corn</i>	<i>Cocoa</i>
Lower explosion level	30 g/m ³	60 g/m ³	60 g/m ³	125 g/m ³
Ignition temperature for a cloud	380 °C	310 ÷ 480 °C	370 °C	560 °C
Ignition temperature for a layer of 5 mm	290 °C	380 ÷ 460 °C	290 °C	NC
Maximum overpressure of explosion	8,6 bar	8,2 bar	9,3 bar	6,7 bar
Minimum ignition energy	5 mJ	10 mJ	60 mJ	100 J

9.8.3 – SOURCES OF RELEASE

The source of release is a point from which the dust can be released or raised (if it is a layer) creating an explosive atmosphere:

- layers of combustible dust in open containers
- layers of deposited dust (on the floor or machines) that can be frequently disturbed; a particular case could be the conveyor belt because it moves and is easier to “disturb the deposited dust”. The movement then increases the extension of the hazardous area
- opening towards the environment of open machines that produce combustible dusts
- bag emptying points and/or small containers
- not hermetically sealed bags
- discontinuity points of machines and pipes

Pictures 36 and 37 refer to potential ignition sources.

9.8.4 – GRADE OF RELEASE

Pictures 36 and 37 show examples of CONTINUOUS, PRIMARY and SECONDARY GRADE releases.

9.8.5 – LOAD OF RELEASE

Neither in this case is it possible to establish a generic load of release, as the cases in which the dust can be out of the containment systems are different so as the ambient conditions. In these cases you must proceed each time with a punctual calculation, which is not possible here.

9.8.6 – TYPE OF ZONE

In these places there are three types of zone: ZONE 20; ZONE 21; ZONE 22.

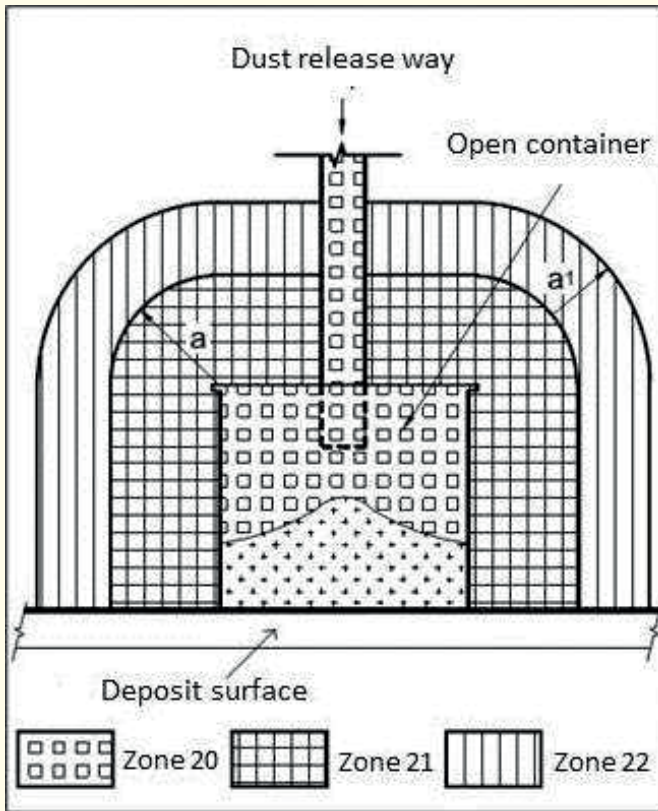

Picture 37: in this case there are more than one source of release; one is the release tube, another is the dust surface inside the container, another one the opening of the container.

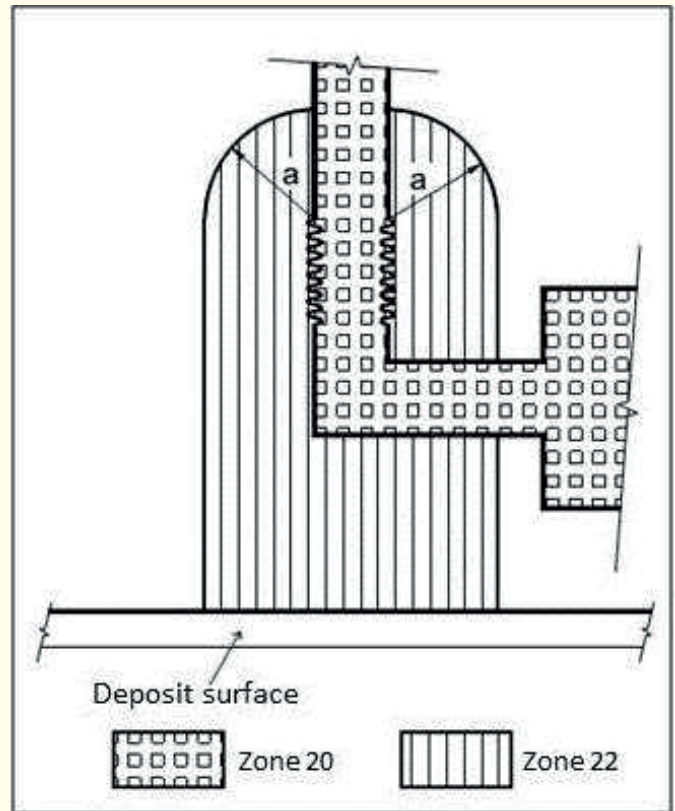

Picture 38: the source of release is the connecting duct made of textile material when for an anomaly it loses the sealing.

Zone 20

Generally there is a ZONE 20 inside containers, mixers, dryers, hoppers, dust ducts. Practically inside containment systems where part of the dust is suspended in the air.

There could be also ZONE 20 out of the containment systems but, in working areas, this condition is forbidden and thus, once located, must be removed.

Zone 21

Generally there is a ZONE 21 close to the containment systems, especially when there are operations of transfer from a containment system to another, as for example: in the surroundings of the hopper openings, during transfer operations of containers done without dust extraction system; around the trench for truck emptying; around the container openings as shown in Picture 37.

Zone 22

It is a ZONE 22 each time it is possible to disperse the dust in air caused by an anomaly or a distraction of the operator, for example:

- extraction system out of use for a fault; from the moment of the fault to its individuation and block of the production there will be a short period in which an explosive atmosphere can occur

- in many cases the extraction system brings the dust in bags that, once full, are emptied manually. During this operation one of the bags can slip through the hands of the operator and fall, break or other and, consequently, be dispersed in air. For a short period the dust can create an explosive atmosphere
- the breaking of a connecting duct made of textile material – they are couplers between tubes or between tubes and extraction system devices – could cause that the contained dust goes out and creates an explosive atmosphere
- the deposited dust accidentally raised from the ground – for example using compressed air – and mixed with air could create an explosive atmosphere.

9.8.7 – HAZARDOUS DISTANCE

The cases in which the dust can be dispersed in air are very different and it is not possible to give an estimated size. For this reason, the reference in such case will be the results produced by who classifies the area.

9.8.8 – HAZARDOUS AREA CLASSIFICATION

In this environment – we mean only those with presence of combustible dust – the level of housekeeping is considered poor (see chapter 9.3.4).

This means that a big part of the areas where there is dust (moving or deposited) can be classified as ZONE 21 and ZONE 22.

Chap.10: INSTALLATION METHODS

10.1 - GENERALITIES

In this chapter we will refer to all the information of the previous ones in order to develop installation methods for some specific activities. Particularly the paragraphs are closely linked to those of chapter 9.

After the classification is done and the danger in different areas of the factory is assessed, the employer – for the law who takes decisions and has spending power in the factory – must take all the preventing measures to avoid an explosion.

The main measure is to avoid the creation of an explosive atmosphere; when this is not possible, all the potential ignition sources must be removed.

In chapter 2 we explained that an explosion occurs if there is contemporary presence of an explosive atmosphere and an ignition source.

The electrical plant could be an ignition source and for this reason all the protection measures must be taken in order to reduce the explosion hazard to an acceptable level.

There are different types of protection (chapter 4) for the electrical equipment in hazardous areas. In this chapter we will give some indications to select and assemble electrical installation in explosive atmospheres, in the places examined in the previous chapter.

When you do an electrical plant you must do all the possible to prevent any danger linked to the use of materials and equipment. Particularly the electrical plant must not cause:

- A) damages to living beings
- B) material damages
- C) fault of electrical and electronic plants

MAIN DANGER THAT THE ELECTRICAL PLANT CAN CAUSE	CONSEQUENT EFFECTS
direct contacts	burns respiratory arrest
indirect contacts	heart fibrillation
overcurrents	burns
electric arc	fire ignition explosion ignition
thermal effects	electrical plant inopportunistly out of voltage
overvoltage due to atmospheric conditions or wrong operations	
external influences due to - atmospheric agents: sun, rain, wind... - impacts, vibrations - corrosive agents	material damages of components that consequently could cause the above listed dangers

Table 31: main dangers that the electrical plant can cause and consequent effects

10.2 – TERMS AND DEFINITIONS

Component of the installation

Each element used for production, transformation, transmission or electric energy distribution such as machines, transformers, equipment, measuring tools, protection devices, pipes.

Group of an equipment for explosive atmosphere

Classification of an electrical equipment according to the explosive atmosphere for which it is intended.

Hazardous area

Area where an explosive atmosphere is or can be present in such a quantity that requires particular measures for realization, installation and use of equipment.

10.3 – BRIEF GENERAL INFORMATION

By the way, the following information refers to points that could trigger an explosive atmosphere. Information is general and synthetic.

10.3.1 - OVERLOAD

The overload is a fault current, is a current of bigger intensity than the rated one and happens in a healthy circuit.

There is an overload when the circuit rated current overpasses the conductor rated load and the rated current is the maximum value expected in the project calculations.

There can be temporary overloads (starting of a system component that requires a high breakaway starting current) or permanent or persistent overloads (for example system components used over their rated value).

Here below there are some cases where an overload can occur:

Circuits with sockets

A circuit that connects a series of sockets is never dimensioned for the value of the sum of the rated currents of all the sockets present in the installation. It is usually calculated with a coincidence factor, a factor that reduces the maximum possible value to a value more adequate to what is expected. When the real current overpasses the expected, for different reasons, there is an overload.

If a circuit has only one socket, dedicated to a precise user device, the eventual overload is caused by an anomaly in this device.

Circuits that power motors

When the motors are subject to a bigger effort than the one for which they are intended (improper use of the equipment), they require a higher current than the rated one and create an overload.

Circuits that power transformers

When the load connected to the secondary of a transformer overpasses the rated power, it creates an overload.

– Overload: how to defend yourself?

In an electrical circuit a protection device must be installed in order to intervene every time the current takes values able to cause a dangerous heating for the insulation of the conductors, connections, terminals and surrounding environment.

The general rule is the following:

- the load of the conductors (I_z) must be bigger than (or equal to) the rated current of the protection device (I_n) that must be bigger than (or equal to) the rated current (I_B).

What above can be expressed with the formula:

$$I_z \geq I_n \geq I_B$$

– Overload: conclusions

In the end, an overload could be the cause of the ignition of an explosive atmosphere.

In the classified areas, a wrongly dimensioned protection device could be the cause of an undesired ignition.

10.3.2 – SHORT-CIRCUIT

Overcurrent that occurs after a fault of negligible impedance between two points that have voltage in normal operating current.

Differently from the overload, the short-circuit is an overcurrent that occurs due to a fault and this is a valid reason to interrupt it. Moreover, it is usually an overcurrent much higher than the one that can be created by an overload.

– Short-circuit: conclusions

To conclude, if the overload could cause the trigger of an explosion, the short-circuit will definitely occur. Also in this case, it is necessary to install a protection device that can interrupt the current to bring the conductor temperature to an acceptable limit.

In order to do it, this principle must be followed: the energy that the MCB allows to pass before opening must not overpass the maximum allowed by the conductors.

What above is expressed by the formula:

$$I^2t \leq K^2S^2$$

where:

- I^2t specific energy that passes through the protection device
- K factor whose value depends on the conductor material, insulation, initial and final temperature that the cable can withstand without damaging
- S section of the conductor

10.3.3 – ELECTRIC ARC

This aspect has already been examined in chapter 2; here below some other observations are added.

An electric arc sometimes is a desired event (for example it is produced for welding), some other times it is an undesired event (interesting case for us). An electric arc can be ignited for different reasons and, consequently, the solutions to avoid this event are different.

Some examples for which adequate measures must be taken:

- an arc that could be triggered by an overvoltage caused by atmospheric agents
- an arc that could be triggered by an overvoltage caused by opening and closing of protection and control devices
- an arc that could be triggered by loosened connection terminals creating the condition of two far electrodes (less than one millimeter).

10.3.4 – DANGEROUS SPARKS

The use of components in insulating material according to the type and specific conditions create electrostatic discharges, sparks that could (according to the energy produced) ignite an explosive atmosphere.

An immediate solution could be to use components with metallic external parts; but also in this case there are some dangers to consider: if the metallic components suffer impacts or frictions, they can create dangerous sparks.

The components must not contain in mass more than:

group II - gas or vapours	group III - dust
EPL "Ga"	EPL "Da"
10% in total for aluminium, titanium or zirconium	7,5% in total for magnesium, titanium or zirconium
EPL "Ga" e "Gb"	EPL "Db"
7,5% in total for aluminium, titanium or zirconium	7,5% in total for magnesium, titanium or zirconium
EPL "Gc"	EPL "Dc"
no particular requirements	no particular requirements

Table 32: maximum percentage allowed of some substances according to groups and EPL

10.3.5 – STATIC ELECTRICITY

To connect with the previous chapter, an arc could be triggered by an effect of electrostatic charge accumulation. Being a discharge that happens in a very limited period, more than the arc, we can define the electrostatic discharge as a spark.

In the insulating materials, differently from the conductors (usually made of metal), the electrostatic discharge are stable in time (static) and when they charge, for example for rubbing, they keep the charge.

In metallic materials the positive and negative charges are free to move and do not accumulate. Practically an earth connection favours the disposal of the electrical charges.

In case of contact between positively charged elements with negatively charged elements an electrostatic discharge occurs. By the way, the electrostatic discharge accumulated by a person can reach 135 mJ, value bigger than the majority of the minimum ignition energies of explosive atmosphere air-gas/vapour and air-dust.

For other information regarding electrostatic discharge you can also read chapter 2.

10.3.6 – THERMAL EFFECTS

One of the unavoidable consequences of the passage of an electrical current in a circuit is the increase of temperature. The Joule effect (heating) in an electrical equipment occurs due to:

- rated current flowing (normal functioning)
- overcurrents (shortcircuit, overload – see previous chapters)
- fault of earth current
- bad contacts (terminals that can loosen with time).

Even if the equipment is protected by a case, part of the heating is transferred also to the case which takes a temperature that, during normal functioning, stabilizes only when it reaches the thermal regime.

When the temperature of the equipment overpasses the limit of ignition for an explosive mixture, it can become the trigger of the explosion.

10.4 - GARAGES

10.4.1 - GENERALITIES

For garage it is intended a place where vehicles are sheltered and, in this specific case, other activities which are sometimes present are excluded, such as: refueling areas, areas with car repair activities.

Different types of garage are identified in the previous chapter; according to the type, the selection and installation of the components may be different.

10.4.2 - EXPLOSION

From the point of view of the explosion, in a garage the undesired event is the ignition of the fuel contained in the vehicles released for a fault. As seen in the previous chapter, the probable release of fuel can cause a zone 2 on the floor which is generally with negligible extension.

10.4.3 - FIRE

From the point of view of fire, in a garage the undesired event is proportional to the number of vehicles present. A fire will obviously last more in the case that is fuelled by a higher number of vehicles.

10.4.4 - EXTERNAL INFLUENCES

Regarding external influences, in a garage one of the dangers to consider is the damage that an electrical component could suffer after an impact with a vehicle. As described above, a damaged component could be the cause of a short-circuit or an overtemperature that could then provoke a fire.

Among the external influences, then, the ambient temperature must be considered; as a matter of fact, the garages even though they are covered in winter months must withstand temperatures below zero.

10.4.5 - SELECTION AND INSTALLATION OF ELECTRICAL COMPONENTS

Provided that it is assessed the persistence of all the conditions expressed in the previous chapter, conditions which led to exclude a danger of explosion, the fire hazard assessment is still to be done.

The main theme of this book is not fire hazard but it is useful to give some synthetic information, a warning that gives a particular attention in the construction of the electrical plants in these places. When the number of the vehicles present in a garage is high (for example when the surface reaches 1000 m²) a fire causes a risk bigger than a normal environment.

In common cases a private garage contains a small number of vehicles and for this it is not included in the example above.

In a private garage the electrical equipment is generally composed of lighting devices, control points to switch the lamps, sockets and connecting tubes.

But the main risk of a fire can be found in public garages, for example the underground parking of a commercial center.

In public garages, the electrical equipment is composed of lighting devices and connecting tubes.

In places with fire hazard due to the presence of flammable substances (in this case the fuel of the vehicles) the electrical components must be placed inside enclosures with protection rating not less than IP4X.

Domestic sockets and lighting control devices are exceptions.

In order to reduce the danger of damages caused by moving vehicles, the electrical equipment must be placed in appropriate positions:

- components such as switches, sockets and others, must be placed inside niches, where walls create an angle or out of action zones, as to say in places where the vehicles cannot impact. The installation height must be more than the vehicle bumpers (generally is the most prominent part if we do not consider the wing mirrors). Moreover, to facilitate disable people that uses wheelchairs, the height must be more than 140 cm from the ground.

When the danger of damage is an event to be considered – impacts of small strength – components with a high mechanical protection degree must be considered: IK 10 (the component can withstand an impact of a weight of 5 kgs dropped from a height of 0,4 m).

For example, these products satisfy all these requirements (IP rating, operating temperature, IK rating):

Component	IP	IK	T
distribution board TAIS CUBE series	66	10	-30 °C ÷ + 100 °C
junction boxes TAIS series	67	10	-40 °C ÷ + 70 °C
control devices (switches) RONDO' series	55	10	-25 °C ÷ + 70 °C
lighting fixtures RINO series	66	9	-25 °C ÷ + 50 °C

Table 33: characteristics of some Palazzoli products that allow a safe use

where:

- component: product of Palazzoli S.p.A.
- IP: protection rating against the penetration of solid bodies and the damaging effects of the water penetration
- IK: impact resistance
- T: operating temperature.

For the non-flushed tubes with vertical run from ceiling to floor, where possible, it is recommended the installation in angles and, where not possible, the use of multipole cables with sheath in protective hard shell classification code 5557.

Crushing resistance	Impact resistance	Minimum operating temperature	Maximum operating temperature
5	5	5	7
4000 N	20 J (IK10)	-45 °C	+400 °C

Table 34: explication of the classification code 5557

10.5 – CAR REPAIR SHOPS

10.5.1 - GENERALITIES

Car repair shops can be divided in two categories:

- category A: car repair shops where there are not activities on the fuel, no hot working and no underground pit; for example a car electrical repair shop, a shop of an installer of burglar alarm or some particular sound system, the tire repair shop, etc.
- category B: car repair shop where there are activities on the fuel, hot workings (welding or working on the vehicle components that can be a source of ignition) or underground pits.

10.5.2 - EXPLOSION

From the point of view of the explosion, in a car repair shops of category A the undesired event is the ignition of the fuel contained in the vehicles released for a fault. As seen in the previous chapter, the probable release of fuel can cause a zone 2 on the floor which is generally with negligible extension.

In a car repair shop of category B the danger is the ignition of the fuel contained in the vehicles released for a fault or accidentally spilt by the operator during tank fulfilling and emptying operations or interventions on the fuel circuit.

10.5.3 - FIRE

From the point of view of fire, in a car repair shop the undesired event is proportional to the number of vehicles present and the type of working done; for example in the car repair shops where fuel circuit is repaired, if adequate measures were not taken, there would be a higher probability of fire than, for example, a car wash.

10.5.3 - EXTERNAL INFLUENCES

In a car repair shop – both of category A and B – one of the dangers to consider is the damage that an electrical component could suffer after an impact with a vehicle. As for garages, a damaged component could be the cause of a short-circuit or an over temperature that could then provoke a fire.

10.5.3 - SELECTION AND INSTALLATION OF ELECTRICAL COMPONENTS

In the car repair shops of category A, for the continuous presence of personnel and following the indications for the garages, the place is not considered hazardous.

For the selection and installation of electrical components general principles for an industrial area must be followed, considering the danger of possible impacts caused by moving vehicles.

In the car repair shops of category B it is recommended to establish an area of the shop dedicated to the workings on the fuel circuits.

In this area, the classification could identify ZONES 1 and ZONES 2.

Zone 1

In ZONES 1 all the measures must be taken to limit the extension as much as possible; doing so it becomes more feasible the purpose not to install electrical components that could ignite the explosive atmosphere and, consequently, increase the safety.

In the examined case the component to install must be marked according to the Directive ATEX 2014/34/EU with the following data or with data that indicate a higher protection.

in a ZONE 1 caused by gasoline, LPG o CNG	in a ZONE 1 caused by hydrogen
CE_{Ex} II 2G Ex-e IIA T3 Gb	CE_{Ex} II 2G Ex-e IIC T1 Gb
II places with presence of explosive atmosphere different from the mines	II places with presence of explosive atmosphere different from the mines
2 equipment designed to operate in conformity with the parameters established and guarantee a high protection level	2 equipment designed to operate in conformity with the parameters established and guarantee a high protection level
G gas	G gas
EX e increased safety type of protection	EX e increased safety type of protection
IIA group of the gas (for the example case: gasoline, LPG, CNG)	IIC group of the hydrogen and acetylene
T3 gas ignition temperature >200 °C; maximum surface temperature allowed 195 °C	T1 gas ignition temperature >450 °C; maximum surface temperature allowed 440 °C
Gb the equipment do not ignite during normal operation and in case of a fault	Gb the equipment do not ignite during normal operation and in case of a fault

For the ZONE 1 and ZONE 2 the following components are recommended:

	<p>boxes in aluminium alloy ALUPRES-EX series boxes in thermosetting (GRP) TAIS-EX series</p> <p>CE_{Ex} II 2G Ex e IIC Gb</p> <p>NOTE: on the left a picture of the box in thermosetting (GRP) TAIS-EX series</p>
---	---

cable glands UNI-EX series	CE_{Ex} II 2G Ex-e II
adapters UNI-EX series	CE_{Ex} II 2G Ex-d IIC

Zone 2

In the ZONES 2, generally more extended than ZONE 1, the electrical components must be marked according to the Directive ATEX 2014/34/EU or one that indicates a higher protection:

in a ZONE 2 caused by gasoline, LPG or CNG	
CE Ex II 3G Ex-n IIA T3 Gc	
II	places with presence of explosive atmosphere different from the mines
3	equipment designed to operate in conformity with the parameters established and guarantee a normal protection level
G	gas
EX n	type of protection n
IIA	group of the gas (for the example case: gasoline, LPG, CNG)
T3	gas ignition temperature >200 °C; maximum surface temperature allowed 195 °C
Gc	the equipment do not ignite during normal operation

An aspect to be remembered is the use of mobile, portable and personal equipment. These devices could be temporary introduced in an hazardous area and be an ignition source. These objects are not part of the electrical plant but it is useful to emphasize also this aspect, particularly the devices that are connected to the sockets. Once assessed that the mobile or portable devices are adequate for that hazardous zone, they must be equipped with a plug with the same marking of the socket installed.

These components are recommended:

	<p>switched sockets with mechanical interlock with enclosure in antistatic thermosetting (GRP), IP66 protection rating, TAIS-EX series</p> <p>CE Ex II 3G Ex-nR IIC T6 Gc</p> <p>NOTE: on the left a picture of 463126EX wall mounted switched interlocked 2P+E, 16 A, 230 V</p>
---	---



switched sockets with mechanical interlock with enclosure in aluminium alloy, IP 66 protection rating, ALUPRES-EX series

CE  II 3G Ex-nR IIC T6 Gc

NOTE: on the left a picture of 465136EX wall mounted switched interlocked 3P+E, 16 A, 400 V



isolator switches in aluminium alloy, IP66 protection rating, CAM-EX series

CE  II 3G Ex-nR IIC T6 Gc



TAIS MIGNON EX



RONDO' EX

small control devices in antistatic thermosetting (GRP), IP 66 protection rating, TAIS MIGNON-EX series

small control devices in aluminium alloy, IP 66 protection rating, RONDO'-EX series

CE  II 3G Ex-nR IIC T6 Gc



lighting fixtures in stainless steel AISI 304, diffuser in tempered glass, IP 66 protection rating, G13 T8 lampholder, RINO-EX series

CE  II 3G Ex-nA IIC T4 Gc

Other useful information for all the areas of the shop

The electrical components must be used within their rated power, current, voltage and frequency declared by the manufacturer.

For example the socket in the picture has the following characteristics:

	<i>Palazzoli code</i>	<i>Rated current</i>
	470126	16 A
	<i>Rated voltage</i>	<i>Poles</i>
	230 V	2P+E

It is a socket with 16A rated current, this means that it is predisposed to receive plugs with 16A but this does not exclude that the load can overpass this limit. For this reason it is necessary to install a protection device, such as an MCB.

10.6 – THERMAL PLANTS

10.6.1 - GENERALITIES

The thermal plant is composed of one or more rooms connected to each other, exclusively intended for heat production.

10.6.2 - EXPLOSION

From the point of view of explosion, in a thermal plant the danger is represented by a thermal plant and more precisely the undesired event is the ignition of the fuel – in the specific case the natural gas – released because of a discontinuity of the gas circuit (flanges, electrovalves, threaded joints, etc..).

The gas release is an abnormal event and includes faults, non-correct use or distractions of the operator; events that can be considered as rare.

Discontinuity points are the probable sources of release; in the particular cases listed here below, the releases cause hazardous zones with negligible extension, ZONE 2NE:

- the plants are realized and supervised in compliance with laws and technical standards
- the activities in the thermal plant are performed by people properly skilled about explosive atmosphere risk, ignition sources and means of prevention and protection
- the operation rated pressure is between 20 mbar and 500 mbar
- the dimensions of the release holes do not overpass 0,25 mm².

In case of thermal plant where there are flanges with compressed fibers gasket, it is recommended to assume a release hole of 2,5 mm² dimensions; in this case since one of the conditions above is not respected, we configure a ZONE 2.

10.6.3 - FIRE

From the point of view of fire, in a thermal plant the undesired event is proportional to the power of the thermal plant.

10.6.4 - EXTERNAL INFLUENCES

In a thermal plant there are no particular dangers due to external influences.

It is practically a closed environment where the negative effects of atmospheric agents, plants and animals are excluded.

It is a covered, close space. The only permanent connections with the external are the fix openings which are standardized by the law. To avoid the ingress of animals, some grilles are applied on the openings. They allow only small insects or dust.

10.6.5 - SELECTION AND INSTALLATION OF ELECTRICAL COMPONENTS

Generally, all the technical measures for building an ordinary electrical plant are valid. Particularly since it is a technical environment to improve the maintenance and identification of the components in the installation, a wall-mounted installation is recommended. Considering the openings, it is also recommended a protection rating not less than IP44.

In case of thermal plants there is the possibility of ZONE 2, the components to install must be marked according to the Directive ATEX 2014/34/EU or one that indicates a higher protection level.

in a ZONE 2 caused by natural gas

CE  II 3G Ex-n IIA T1 Gc

These components are recommended:



small control devices in antistatic thermosetting (GRP), IP 66 protection rating, TAIS MIGNON-EX series

small control devices in aluminium alloy, IP 66 protection rating, RONDO'-EX series

CE  II 3G Ex-nR IIC T6 Gc



lighting fixtures in stainless steel AISI 304, diffuser in tempered glass, IP 66 protection rating, G13 T8 lampholder, RINO-EX series

CE Ex II 3G Ex-nA IIC T4 Gc

10.7 - CARPENTRIES

10.7.1 - EXPLOSION

In order that an explosion occurs, there must be the following conditions:

- presence of dust
- dispersion of dust in air (cloud with minimum density of 40 g/m³)
- the oxygen
- the ignition source (minimum ignition energy 30 mJ).

In a carpentry the dust is generally produced using machines that perform finishing workings, such as finishing or sizing machines; circular saws, for example, mainly produce wood chips and small quantities of dust.

In the factories that work wood the probability of a ZONE 20 or ZONE 21 is low, but it is more likely to identify potential ZONE 22 where, during normal activity, the quantity of dust is not sufficient to create an explosive atmosphere but in case of an anomaly – stop of the extraction system, a distraction or carelessness of the operator – this condition could happen.

Zone 21

In the classified volumes with danger of explosion it is preferred not to install electrical components, but this is not always possible. In the volumes classified as ZONE 21, if it is not possible to remove all the electrical components, it is better to limit only to ducts and junction boxes.

Zone 22

Generally (it is not a rule) the ZONE 22 is a volume of about 10 m³, this is to say that it is rare to find all the working areas as ZONE 22 but only parts.

ZONE 22 is usually close to the machines that for type of working do not produce wood chips but sawdust (finishing machines, sizing machines and similar).

In volumes classified as ZONE 22 the electrical components that can be found are junction boxes and industrial sockets.

10.7.2 – FIRE AND EXTERNAL INFLUENCES

In a carpentry elements are supposed to move; for their dimension, they could escape the operator control and cause damages to the devices (danger of impacts with consequent mechanical damage). A damaged component, as already written, could be the cause of a short-circuit or an overtemperature that could provoke a fire.

10.7.3 – SELECTION AND INSTALLATION OF ELECTRICAL COMPONENTS

In the examined case the components to install must be marked according to the ATEX Directive 2014/34/EU with the following characteristics or one that indicates a higher protection level:

in a ZONE 21 caused by sawdust	in a ZONE 22 caused by sawdust
<p>CE^{Ex} II 2D Ex-tb IIIB T200 °C Db</p>	<p>CE^{Ex} II 3D Ex-tc IIIB T200°C Dc</p>
<p>II places with presence of explosive atmosphere different from the mines</p> <p>2 equipment designed to operate in conformity with the parameters established and guarantee a high protection level</p> <p>D dust</p> <p>tb protection by enclosure</p> <p>IIIB non-conductive dust</p> <p>T200 °C (note 1)</p> <p>Db normal protection level + one fault</p>	<p>II places with presence of explosive atmosphere different from the mines</p> <p>3 equipment designed to operate in conformity with the parameters established and guarantee a normal protection level</p> <p>D dust</p> <p>tc protection by enclosure</p> <p>IIIB non-conductive dust</p> <p>T200 °C (note 1)</p> <p>Dc normal protection level</p>

note 1) the selection of the maximum surface temperature has been made considering the ignition temperature of a layer of sawdust (310 °C) reduced of 75 °C and rounded down.

The following components are recommended and suitable both for ZONE 21 and ZONE 22:

	<p>boxes in thermosetting (GRP) TAIS-EX series</p> <p>CE^{Ex} II 2D Ex-tb IIIC Db</p> <p>NOTE: since they are boxes without electrical devices there is no indication on the maximum surface temperature</p>
---	--



switched sockets with mechanical interlock with enclosure in antistatic thermosetting (GRP), TAIS-EX series

CE  II 2D Ex-tb IIIC 115 °C Db IP66

Note: the sockets must be equipped with an interlock; and since the dusts are non-conductive the protection rating must not be less than IP55.

Major risk in case of fire

Once assessed that in the factory there is an environment with fire hazard for the presence of flammable substances (in this case wood under working or deposited) the electrical components must be placed inside enclosures with a protection rating not less than IP 4X.

When the danger of damage is an event to be considered – impacts of small strength – components with a high mechanical protection degree must be considered: IK 10 (the component can withstand an impact of a weight of 5 kgs dropped from a height of 0,4 m).

For example, these products satisfy all these requirements (IP rating, operating temperature, IK rating):

Component	IP	IK	T
distribution board TAIS CUBE series	66	10	-30 °C ÷ + 100 °C
junction boxes TAIS series	67	10	-40 °C ÷ + 70 °C
control devices (switches) RONDO' series	55	10	-25 °C ÷ + 70 °C
lighting fixtures RINO series	66	9	-25 °C ÷ + 50 °C

Table 35: characteristics of some Palazzoli products that allow a safe use

where:

- component: product of Palazzoli S.p.A.
- IP: protection rating against the penetration of solid bodies and the damaging effects of the water penetration
- IK: impact resistance
- T: operating temperature.

10.8 – AGRICULTURAL INDUSTRIES

10.8.1 - GENERALITIES

In this paragraph we will analyse the industries of the primary sector, those that deal with cereals, legumes, peanuts, cocoa, coffee, sugar and other agricultural products.

In these places, during the movement and deposit of the above mentioned products, clouds are created; as to say, tiny particles with dimensions equal to or less than 0,5 mm.

10.8.2 - EXPLOSION

In order that an explosion occurs, there must be the following conditions:

- presence of dust
- dispersion of dust in air (cloud with minimum density of 40 g/m³)
- the oxygen
- the ignition source (minimum ignition energy 30 mJ).

Differently from the carpentries where the only element is wood, here the elements are many more and each one with different characteristics.

In the table taken from Chapter 9 some data of these elements are quoted:

	<i>Rice</i>	<i>Sugar</i>	<i>Corn</i>	<i>Cocoa</i>
Lower explosion level	30 g/m ³	60 g/m ³	60 g/m ³	125 g/m ³
Ignition temperature for a cloud	380 °C	310 ÷ 480 °C	370 °C	560 °C
Ignition temperature for a layer of 5 mm	290 °C	380 ÷ 460 °C	290 °C	NC
Minimum ignition energy	5 mJ	10 mJ	60 mJ	100 J

Table 36: some characteristics of flammable substances

As it is possible to see in the table, the minimum ignition energy for RICE or SUGAR is very small if compared with the one of COCOA.

In order to select the electrical components it is important to consult the classification of the hazardous zones.

10.8.3 - FIRE

From the point of view of fire the following cases must be considered:

- mills for cereals or other materials to be grinded with a daily potentiality of more than 20 tons; cereal deposits and other products with a daily mass of more than 50 tons
- plants for drying cereals and vegetables with deposit of dried products with quantities in mass of more than 50 tons
- sugar factories and sugar refineries
- bakeries and rice mills with a daily production of more than 50 tons.

10.8.4 – EXTERNAL INFLUENCES

There are industrial environments with outdoor areas, areas with roofs and closed areas; as to say different areas that require different evaluations.

Outdoor areas are influenced by atmospheric agents, such as sun, rain, hail, snow, wind, plants and animals.

In indoor areas, if without heating, the low temperatures must be considered. Indoor areas with standard ambient conditions, explosion and fire must be considered.

10.8.5 – SELECTION AND INSTALLATION OF ELECTRICAL COMPONENTS

Zone 20

Generally there is a ZONE 20 inside containers, mixers, dryers, hoppers, dust ducts; practically inside containment systems where part of the dust is suspended in the air.

In these volumes, electrical components are rare; they are control elements such as level sensors, elements that use intrinsic safety as type of protection.

Zone 21

In the classified volumes with danger of explosion it is preferred not to install electrical components, but this is not always possible. In the volumes classified as ZONE 21, if it is not possible to remove all the electrical components, it is better to limit only to ducts and junction boxes.

Zone 22

In volumes classified as ZONE 22 the electrical components that can be found are junction boxes and industrial sockets.

Marking

In the examined case the components to install must be marked according to the ATEX Directive 2014/34/EU with the following characteristics or one that indicates a higher protection level.

Among the different factors to consider there is the ignition temperature of the cloud, that is different according to the type of material:

- for the cocoa the T of the marking can be 480 °C
- for the rice 300 °C
- for the sugar the following table must be reported

<p>in a ZONE 21 caused by sugar dust</p> <p>CE Ex II 2D Ex-tb IIIB T200 °C Db</p>	<p>in a ZONE 22 caused by sugar dust</p> <p>CE Ex II 3D Ex-tc IIIB T200°C Dc</p>
<p>II places with presence of explosive atmosphere different from the mines</p> <p>2 equipment designed to operate in conformity with the parameters established and guarantee a high protection level</p> <p>D dust</p> <p>tb protection by enclosure</p> <p>IIIB non-conductive dust</p> <p>T200 °C (note 1)</p> <p>Db normal protection level + one fault</p>	<p>II places with presence of explosive atmosphere different from the mines</p> <p>3 equipment designed to operate in conformity with the parameters established and guarantee a normal protection level</p> <p>D dust</p> <p>tc protection by enclosure</p> <p>IIIB non-conductive dust</p> <p>T200 °C (note 1)</p> <p>Dc normal protection level</p>

note 1) the selection of the maximum surface temperature has been made considering the ignition temperature of a layer of sugar dust (310 °C) reduced of 75 °C and rounded down.

The following components are recommended and suitable both for ZONE 21 and ZONE 22:

	<p>boxes in thermosetting (GRP) TAIS-EX series</p> <p>CE Ex II 2D Ex-tb IIIC Db</p> <p>NOTE: since they are boxes without electrical devices there is no indication on the maximum surface temperature</p>
	<p>switched sockets with mechanical interlock with enclosure in antistatic thermosetting (GRP), TAIS-EX series</p> <p>CE Ex II 2D Ex-tb IIIC 115 °C Db IP66</p>

Note: the sockets must be equipped with an interlock and since the dusts are non-conductive the protection rating must not be less than IP55.

Chap.11: PROCEDURE FOR TEMPORARY TESTS

11.1 - GENERALITIES

The evolving of the state of an electrical plant must be constantly monitored to evaluate the maintaining in time of the characteristics of safety and reliability of the components.

This means that periodic inspections must be performed in order to individuate anomalies or traces of possible future anomalies; once the potential irregularities have been found, maintenance has to be guaranteed.

IEC EN 60079-17 standard, article 3.6 - **inspection**

action comprising careful scrutiny of an item carried out either without dismantling, or with the addition of partial dismantling as required, supplemented by means such as measurement, in order to arrive at a reliable conclusion as to the condition of an item.

IEC EN 60079-17, article 3.7 - **maintenance**

combination of any actions carried out to retain an item in, or restore it to, conditions in which it is able to meet the requirements of the relevant specification and perform its required functions.

The reference standard of this topic is the IEC EN 60079-17.

11.2 – INSPECTION AND MAINTENANCE

In the IEC EN 60079-17 there are three different levels of inspection:

- visual
- close
- detailed.

Generally the visual and/or close inspections can be done with equipment under voltage because this intervention does not jeopardize the type of protection.

The intervention between inspections cannot be standardized; the maintaining in time of the characteristics of safety and reliability of the components is closely linked to the type of working done in the factory.

Some industrial processes, because of the products used or the movement of objects difficult to handle, could cause a quick deterioration to the components of the installation.

To establish the intervention time it is recommended at the beginning a period of six months. After the first one, verified the deterioration of the equipment and the variation from the previous inspection, the time can be shifted to one year; in any case the inspection time must not exceed three years.

Procedure

To ensure that the installations are maintained in satisfying conditions, the procedure is the following:

- perform an inspection of close type (after the first complete inspection)
- after that, it can be evaluated if an increase of the inspection time can be justified
- in any case the inspection time must not be more than three years
- consider if the intervention of skilled personnel is necessary.

Types of inspection

- The initial inspections (the production process is not started yet) must be detailed and on all the electrical plant. The initial inspections must assess the correspondence with the project.
- The periodic inspections according to the specific cases can be visual, close or detailed. Unless particular warnings the inspection can be done on samples.

11.3 - INSULATION

For the detailed inspections, the majority of the cases requires that the plant is out of voltage. In areas that require EPL Gc or Dc (ZONE 2 or ZONE 22) the work can be done taking preventing measures for a non-hazardous area, but respecting the following safety conditions:

- prepare the maintenance in order to guarantee the absence of sparks that can ignite, during the working
- the circuits are designed in order to exclude the production of sparks
- the hot surfaces of the equipment cannot create an explosion.

11.4 - EQUIPMENT WITHOUT MARKING

It is not rare that the markings placed on the equipments protected against explosion are missing or non-legible. On a device installed in places in which the type of working can erase the marking (for example factories that produce inks or particular resins), additional markings can be placed. The additional markings must not compromise the integrity of the equipment.

11.5 - DOCUMENTATION

To perform inspection or maintenance skillfully, the documentation of the installation must be available. The documentation must contain:

- the classification of the area.
 - NOTE: the factory plant layout with the indication of the hazardous zones. This document will allow for the maintainer to locate whether the position of the interventions is inside or close to a classified area, or if it is in a safe area
- the Equipment Protection Level of the devices (see paragraph 3.2)
- the marking according to the ATEX directive (see paragraph 6.4.2)
 - NOTE: if the maintenance requires the replacement of a component damaged or close to deterioration, this must be compatible with the rest of the installation and in conformity with the hazardous zone
- the documentation of the component to be maintained

- the manufacturer generally supplies the instructions on how to maintain in order to keep the conformity with the type of protection of the component
- register copy of the previous initial and periodic inspections
- the register will allow to identify the objects already replaced and eventual notes regarding anomalies for which an intervention has been required. According to the dispositions of the standard the general conditions of the equipment must be noted in order to plan adequate corrective measures.

11.6 - PERSONNEL

The personnel in charge of inspection and maintenance of the installation must be skilled. An approximate maintenance is a high risk for the factory.

Even if skilled, an adequate and continuous training – documented and available – will favour the preparation of the personnel and decrease consequently the probability of an accidental event.

11.7 – INSPECTION TABLES

The following tables are based on the EN 60079-17 standard.

The aim of these tables is to show the complexity of this activity and the reason for which the standard requires that the personnel are skilled.

In the standard for each voice of the table additional indications on how to perform the specific inspection are provided. For this reason, those who intend to try inspections are recommended to consult the standard.

TYPE OF PROTECTION Ex d / Ex e

Periodic inspection according to EN 60079-17 standard Place: _____ Installation: _____

(D = Detailed, C = Close, V = Visual - YES = positive inspection, NO = negative inspection)

D = identifies defects such as loosened internal connections

C = identifies defects such as loosened bolts also with the use of stairs and tools

V = identifies defects visible at naked eye without stairs and tools

X = inspection required

		GRADE OF INSPECTION			RESULT		?
		D	C	V	YES	NO	
A	GENERAL (ALL EQUIPMENT)						
1	Equipment is appropriate to the EPL/Zone requirements of the location	X	X	X			
2	Equipment group is correct	X	X				
3	Equipment temperature class is correct	X	X				
4	Equipment circuit identification is correct	X					
5	Equipment circuit identification is available	X	X	X			
6	Degree of protection (IP grade) of equipment is appropriate for the level of protection/group/ conductivity	X	X	X			
7	There is no evidence of ingress of water or dust in the enclosure in accordance with the IP rating	X					
8	Enclosure, glass parts and glass-to-metal sealing gaskets and/or compounds are satisfactory	X	X	X			
9	There is no damage or unauthorized modifications	X					
10	There is no evidence of unauthorized modifications		X	X			
11	Bolts, cable entry devices (direct and indirect) and blanking elements are of the correct type and are complete and tight						
	Physical check	X	X				
	Visual check			X			
12	Joint surfaces are clean and undamaged and gaskets, if any, are satisfactory and positioned correctly (only for Ex d)	X					
13	Only for Ex d Dimensions of flanged joint gaps are: - within the limits in accordance with manufacturer's documentation or - within maximum values permitted by relevant construction standard at time of installation or - within maximum values permitted by site documentation	X	X				
14	Only for Ex e Electrical connections are tight	X					
15	Only for Ex e Unused terminals are tightened	X					
16	Only for Ex e Flameproof components are undamaged	X					
B	LIGHTING EQUIPMENT						
1	Only for Ex e - Fluorescent lamps are not indicating EOL effects	X	X	X			
2	HID lamps are not indicating EOL effects	X	X	X			
3	Lamp type, rating, pin configuration and position are correct	X					

X = inspection required		GRADE OF INSPECTION			RESULT		?
		D	C	V	YES	NO	
		C	MOTORS				
1	Motor fans have sufficient clearance to the enclosure and/or covers, cooling systems are undamaged, motor foundations have no indentations or cracks	X	X	X			
2	The ventilation airflow is not impeded	X	X	X			
3	Insulation resistance (IR) of the motor windings is satisfactory	X					
D	INSTALLATION						
1	Type of cable is appropriate	X					
2	There is no obvious damage to cables	X	X	X			
3	Sealing of trunking, ducts, pipes and/or conduits is satisfactory	X	X	X			
4	Only for Ex d Stopping boxes and cable boxes are correctly filled	X					
5	Integrity of conduit system and interface with mixed system maintained	X					
6	Earthing connections, including any supplementary earthing bonding connections are satisfactory (for example connections are tight and conductors are of sufficient cross-section)						
	Physical check	X					
	Visual check		X	X			
7	Fault loop impedance (TN systems) or earthing resistance (IT systems) is satisfactory	X					
8	Insulation resistance is satisfactory	X					
9	Automatic electrical protective devices operate within permitted limits	X					
10	Automatic electrical protective devices are set correctly (auto-reset not possible)	X					
11	Specific conditions of use (if applicable) are complied with	X					
12	Cables not in use are correctly terminated	X					
13	Obstructions adjacent to flameproof flanged joints are in accordance with IEC 60079-14	X	X	X			
14	Variable voltage/frequency installation complies with documentation	X	X				
E	HEATING SYSTEMS						
1	Temperature sensors function according to manufacturer's documents	X					
2	Safety cut off devices function according to manufacturer's documents	X					
3	The setting of the safety cut off is sealed	X	X				
4	Automatic recovery is not possible	X	X				
5	Reset of a heating system safety cut off possible with tool only	X					
6	Safety cut off independent from control system	X					
7	Level switch is installed and correctly set, if required	X					
8	Flow switch is installed and correctly set, if required	X					
F	MOTORS						
1	Only for Ex e Motor protection devices operate within the permitted t_E or t_A time limits	X					
G	ENVIRONMENT						
1	Equipment is adequately protected against corrosion, weather, vibration and other adverse factors	X	X	X			
2	No undue accumulation of dust and dirt	X	X	X			

TYPE OF PROTECTION Ex n

Periodic inspection according to EN 60079-17 standard Place: _____ Installation: _____

(D = Detailed, C = Close, V = Visual - YES = positive inspection, NO = negative inspection)

D = identifies defects such as loosened internal connections

C = identifies defects such as loosened bolts also with the use of stairs and tools

V = identifies defects visible at naked eye without stairs and tools

X = inspection required

		GRADE OF INSPECTION			RESULT		?
		D	C	V	YES	NO	
A	ELECTRICAL EQUIPMENT						
1	Equipment is appropriate to the EPL/Zone requirements of the location	X	X	X			
2	Equipment group is correct	X	X				
3	Equipment temperature class is correct	X	X				
4	Equipment circuit identification is correct	X					
5	Equipment circuit identification is available	X	X	X			
6	Degree of protection (IP grade) of equipment is appropriate for the level of protection/group/ conductivity	X	X	X			
7	There is no evidence of ingress of water or dust in the enclosure in accordance with the IP rating	X					
8	Enclosure, glass parts and glass-to-metal sealing gaskets and/or compounds are satisfactory	X	X	X			
9	There is no damage or unauthorized modifications	X					
10	There is no evidence of unauthorized modifications		X	X			
11	Bolts, cable entry devices (direct and indirect) and blanking elements are of the correct type and are complete and tight						
	Physical check	X	X				
	Visual check			X			
12	Electrical connections are tight	X					
13	Unused terminals are tightened	X					
14	Enclosed-break and hermetically sealed devices are undamaged	X					
15	Encapsulated components are undamaged	X					
16	Restricted breathing enclosure is satisfactory - (type "nR" only)	X					
17	Test port, if fitted, is functional- (type "nR" only)	X					
18	Breathing operation is satisfactory- (type "nR" only)	X					
19	Breathing and draining devices are satisfactory	X	X				
B	LIGHTING EQUIPMENT						
1	Fluorescent lamps are not indicating EOL effects	X	X	X			
2	HID lamps are not indicating EOL effects	X	X	X			
3	Lamp type, rating, pin configuration and position are correct	X					
C	MOTORS						
1	Motor fans have sufficient clearance to the enclosure and/or covers, cooling systems are undamaged, motor foundations have no indentations or cracks	X	X	X			
2	The ventilation airflow is not impeded	X	X	X			
3	Insulation resistance (IR) of the motor windings is satisfactory	X					

X = inspection required		GRADE OF INSPECTION			RESULT		?
		D	C	V	YES	NO	
D	INSTALLATION						
1	Type of cable is appropriate	X					
2	There is no obvious damage to cables	X	X	X			
3	Sealing of trunking, ducts, pipes and/or conduits is satisfactory	X	X	X			
4	Integrity of conduit system and interface with mixed system maintained	X					
5	Earthing connections, including any supplementary earthing bonding connections are satisfactory (for example connections are tight and conductors are of sufficient cross-section)						
	Physical check	X					
	Visual check		X	X			
6	Fault loop impedance (TN systems) or earthing resistance (IT systems) is satisfactory	X					
7	Insulation resistance is satisfactory	X					
8	Automatic electrical protective devices operate within permitted limits	X					
9	Automatic electrical protective devices are set correctly (auto-reset not possible)	X					
10	Specific conditions of use (if applicable) are complied with	X					
11	Cables not in use are correctly terminated	X					
12	Variable voltage/frequency installation complies with documentation	X	X				
E	ENVIRONMENT						
1	Equipment is adequately protected against corrosion, weather, vibration and other adverse factors	X	X	X			
2	No undue accumulation of dust and dirt	X	X	X			

Observations _____

Date _____ Inspector _____

TYPE OF PROTECTION Ex t

Periodic inspection according to EN 60079-17 standard Place: _____ Installation: _____

(D = Detailed, C = Close, V = Visual - YES = positive inspection, NO = negative inspection)

D = identifies defects such as loosened internal connections

C = identifies defects such as loosened bolts also with the use of stairs and tools

V = identifies defects visible at naked eye without stairs and tools

X = inspection required

		GRADE OF INSPECTION			RESULT		?
		D	C	V	YES	NO	
A	ELECTRICAL EQUIPMENT						
1	Equipment is appropriate to the EPL/Zone requirements of the location	X	X	X			
2	Equipment group is correct	X	X				
3	Equipment maximum surface temperature is correct	X	X				
4	Equipment circuit identification is correct	X					
5	Equipment circuit identification is available	X	X	X			
6	Degree of protection (IP grade) of equipment is appropriate for the level of protection/group/conductivity	X	X	X			
7	There is no evidence of ingress of water or dust in the enclosure in accordance with the IP rating	X					
8	Enclosure, glass parts and glass-to-metal sealing gaskets and/or compounds are satisfactory	X	X	X			
9	There is no damage or unauthorized modifications	X					
10	There is no evidence of unauthorized modifications		X	X			
11	Bolts, cable entry devices (direct and indirect) and blanking elements are of the correct type and are complete and tight						
	Physical check	X	X				
	Visual check			X			
12	Electrical connections are tight	X					
B	LIGHTING						
1	Fluorescent lamps are not indicating EOL effects	X	X	X			
2	HID lamps are not indicating EOL effects	X	X	X			
3	Lamp type, rating, pin configuration and position are correct	X					
C	MOTORS						
1	Motor fans have sufficient clearance to the enclosure and/or covers, cooling systems are undamaged, motor foundations have no indentations or cracks	X	X	X			
2	The ventilation airflow is not impeded	X	X	X			
3	Insulation resistance (IR) of the motor windings is satisfactory	X					

X = inspection required		GRADE OF INSPECTION			RESULT		?
		D	C	V	YES	NO	
D	INSTALLATION						
1	Type of cable is appropriate	X					
2	There is no obvious damage to cables	X	X	X			
3	Sealing of trunking, ducts, pipes and/or conduits is satisfactory	X	X	X			
4	Integrity of conduit system and interface with mixed system maintained	X					
5	Earthing connections, including any supplementary earthing bonding connections are satisfactory (for example connections are tight and conductors are of sufficient cross-section)						
	Physical check	X					
	Visual check		X	X			
6	Fault loop impedance (TN systems) or earthing resistance (IT systems) is satisfactory	X					
7	Insulation resistance is satisfactory	X					
8	Automatic electrical protective devices operate within permitted limits	X					
9	Automatic electrical protective devices are set correctly (auto-reset not possible)	X					
10	Specific conditions of use (if applicable) are complied with	X					
11	Cables not in use are correctly terminated	X					
12	Variable voltage/frequency installation complies with documentation	X	X				
E	HEATING SYSTEMS						
1	Temperature sensors function according to manufacturer's documents	X					
2	Safety cut off devices function according to manufacturer's documents	X					
F	ENVIRONMENT						
1	Equipment is adequately protected against corrosion, weather, vibration and other adverse factors	X	X	X			
2	No undue accumulation of dust and dirt	X	X	X			

Observations _____

Date _____ Inspector _____

SEQUENTIAL INDEX

Palazzoli code	Marks	Pack Q.ty	Catalogue page
1EX			
150021EX	10-11-12	1	21
2EX			
201151EX	10	1	37
201152EX	10	1	37
201156EX	10	1	37
202271EX	10	1	35
202275EX	10	1	35
202276EX	10	1	35
202282EX	10	1	35
261021EX	10	1	37
261432EX	10	1	35
261433EX	10	1	35
261435EX	10	1	35
261445EX	10	1	35
272141EX	10-11 12-13	1	31
272142EX	10-11 12-13	1	31
272143EX	10-11 12-13	1	31
272144EX	10-11 12-13	1	31
272146EX	10-11 12-13	1	31
272147EX	10-11 12-13	1	31
272241EX	10-11 12-13	1	31
272242EX	10-11 12-13	1	31
272243EX	10-11 12-13	1	31
272244EX	10-11 12-13	1	31
272246EX	10-11 12-13	1	31
272247EX	10-11 12-13	1	31
272301EX	10-11 12-13	1	31
272302EX	10-11 12-13	1	31
272303EX	10-11 12-13	1	31
272304EX	10-11 12-13	1	31
272306EX	10-11 12-13	1	31
272307EX	10-11 12-13	1	31
282402EX	10-11 12-13	1	31
282403EX	10-11 12-13	1	31
282404EX	10-11 12-13	1	31
282406EX	10-11 12-13	1	31
282407EX	10-11 12-13	1	31
292101EX	10-11 12-13	1	29
292102EX	10-11 12-13	1	29
292103EX	10-11 12-13	1	29
292201EX	10-11 12-13	1	29

Palazzoli code	Marks	Pack Q.ty	Catalogue page
292202EX	10-11 12-13	1	29
292203EX	10-11 12-13	1	29
292301EX	10-11 12-13	1	29
292302EX	10-11 12-13	1	29
292303EX	10-11 12-13	1	29
292411EX	10-11 12-13	1	29
292412EX	10-11 12-13	1	29
292413EX	10-11 12-13	1	29
4EX			
460224EX	10-11 12-13	1	15-16
460226EX	10-11 12-13	1	15-16
460229EX	10-11 12-13	1	15-16
460234EX	10-11 12-13	1	15-16
460236EX	10-11 12-13	1	15-16
460237EX	10-11 12-13	1	15-16
460239EX	10-11 12-13	1	15-16
460244EX	10-11 12-13	1	15-16
460246EX	10-11 12-13	1	15-16
460247EX	10-11 12-13	1	15-16
460249EX	10-11 12-13	1	15-16
460324EX	10-11 12-13	1	15-16
460326EX	10-11 12-13	1	15-16
460329EX	10-11 12-13	1	15-16
460334EX	10-11 12-13	1	15-16
460336EX	10-11 12-13	1	15-16
460337EX	10-11 12-13	1	15-16
460339EX	10-11 12-13	1	15-16
460344EX	10-11 12-13	1	15-16
460346EX	10-11 12-13	1	15-16
460347EX	10-11 12-13	1	15-16
460349EX	10-11 12-13	1	15-16
463124EX	10-11-12	1	10-11
463126EX	10-11-12	1	10-11
463129EX	10-11-12	1	10-11
463134EX	10-11-12	1	10-11
463136EX	10-11-12	1	10-11
463137EX	10-11-12	1	10-11
463139EX	10-11-12	1	10-11
463144EX	10-11-12	1	10-11
463146EX	10-11-12	1	10-11
463147EX	10-11-12	1	10-11
463149EX	10-11-12	1	10-11

Palazzoli code	Marks	Pack Q.ty	Catalogue page
463324EX	10-11-12	1	11
463334EX	10-11-12	1	11
463326EX	10-11-12	1	11
463329EX	10-11-12	1	11
463336EX	10-11-12	1	11
463337EX	10-11-12	1	11
463344EX	10-11-12	1	11
463346EX	10-11-12	1	11
463347EX	10-11-12	1	11
463349EX	10-11-12	1	11
464210EX	10-11-12	1	10-12
464220EX	10-11-12	1	10-12
464230EX	10-11-12	1	10-12
464310EX	10-11-12	1	10-12
464320EX	10-11-12	1	10-12
464330EX	10-11-12	1	10-12
464336EX	10-11-12	1	12
464339EX	10-11-12	1	12
464346EX	10-11-12	1	12
464410EX	10-11-12	1	10-12
464420EX	10-11-12	1	10-12
464430EX	10-11-12	1	10-12
464621EX	10-11-12	1	10-12
464711EX	10-11-12	1	10-12
464721EX	10-11-12	1	10-12
464722EX	10-11-12	1	10
464731EX	10-11-12	1	10-12
464732EX	10-11-12	1	10
464811EX	10-11-12	1	10-12
464831EX	10-11-12	1	10-12
464832EX	10-11-12	1	10
465124EX	10-11-12	1	16-17
465126EX	10-11-12	1	16-17
465129EX	10-11-12	1	16-17
465134EX	10-11-12	1	16-17
465136EX	10-11-12	1	16-17
465137EX	10-11-12	1	16-17
465139EX	10-11-12	1	16-17
465144EX	10-11-12	1	16-17
465146EX	10-11-12	1	16-17
465147EX	10-11-12	1	16-17
465149EX	10-11-12	1	16-17

Palazzoli code	Marks	Pack Q.ty	Catalogue page
465324EX	10-11-12	1	17
465326EX	10-11-12	1	17
465329EX	10-11-12	1	17
465334EX	10-11-12	1	17
465336EX	10-11-12	1	17
465337EX	10-11-12	1	17
465339EX	10-11-12	1	17
465344EX	10-11-12	1	17
465346EX	10-11-12	1	17
465347EX	10-11-12	1	17
465349EX	10-11-12	1	17
466124EX	10-11-12	1	15-16
466126EX	10-11-12	1	15-16
466129EX	10-11-12	1	15-16
466134EX	10-11-12	1	15-16
466136EX	10-11-12	1	15-16
466137EX	10-11-12	1	15-16
466139EX	10-11-12	1	15-16
466144EX	10-11-12	1	15-16
466146EX	10-11-12	1	15-16
466147EX	10-11-12	1	15-16
466149EX	10-11-12	1	15-16
467124EX	10-11 12-13	1	9-11
467126EX	10-11 12-13	1	9-11
467129EX	10-11 12-13	1	9-11
467134EX	10-11 12-13	1	9-11
467136EX	10-11 12-13	1	9-11
467137EX	10-11 12-13	1	9-11
467139EX	10-11 12-13	1	9-11
467144EX	10-11 12-13	1	9-11
467146EX	10-11 12-13	1	9-11
467147EX	10-11 12-13	1	9-11
467149EX	10-11 12-13	1	9-11
470224EX	10-11 12-13	1	9-11
470226EX	10-11 12-13	1	9-11
470229EX	10-11 12-13	1	9-11
470234EX	10-11 12-13	1	9-11
470236EX	10-11 12-13	1	9-11
470237EX	10-11 12-13	1	9-11
470239EX	10-11 12-13	1	9-11
470244EX	10-11 12-13	1	9-11
470246EX	10-11 12-13	1	9-11

Mark legend: 10 = ATEX 11 = IECEX 12 = INMETRO

SEQUENTIAL INDEX

Palazzoli code	Marks	Pack Q.ty	Catalogue page
470247EX	10-11 12-13	1	9-11
470249EX	10-11 12-13	1	9-11
470324EX	10-11 12-13	1	9-11
470326EX	10-11 12-13	1	9-11
470329EX	10-11 12-13	1	9-11
470334EX	10-11 12-13	1	9-11
470336EX	10-11 12-13	1	9-11
470337EX	10-11 12-13	1	9-11
470339EX	10-11 12-13	1	9-11
470344EX	10-11 12-13	1	9-11
470346EX	10-11 12-13	1	9-11
470347EX	10-11 12-13	1	9-11
470349EX	10-11 12-13	1	9-11
472236EX	10-11 12-13	1	16-17
472237EX	10-11 12-13	1	16
472246EX	10-11 12-13	1	16-17
472247EX	10-11 12-13	1	16
472256EX	10-11 12-13	1	16-17
472257EX	10-11-12	1	16
472336EX	10-11-12	1	16-17
472337EX	10-11-12	1	16
472346EX	10-11-12	1	16-17
472347EX	10-11-12	1	16
472356EX	10-11-12	1	16-17
472357EX	10-11-12	1	16
472436EX	10-11-12	1	16-17
472437EX	10-11-12	1	16
472446EX	10-11-12	1	16-17
472447EX	10-11-12	1	16
472456EX	10-11-12	1	16-17
472457EX	10-11-12	1	16
472546EX	10-11-12	1	16-17
472547EX	10-11-12	1	16
472556EX	10-11-12	1	16-17
472557EX	10-11-12	1	16
472611EX	10-11-12	1	10-11
472612EX	10-11-12	1	10
472621EX	10-11-12	1	10-11
472622EX	10-11-12	1	10
472631EX	10-11-12	1	10-11
472632EX	10-11-12	1	10
472711EX	10-11-12	1	10-11

Palazzoli code	Marks	Pack Q.ty	Catalogue page
472712EX	10-11-12	1	10
472721EX	10-11-12	1	10-11
472722EX	10-11-12	1	10
472731EX	10-11-12	1	10-11
472732EX	10-11-12	1	10
472751EX	10-11-12	1	10-11
472752EX	10-11-12	1	10
472811EX	10-11-12	1	10-11
472812EX	10-11-12	1	10
472821EX	10-11-12	1	10-11
472822EX	10-11-12	1	10
472831EX	10-11-12	1	10-11
472832EX	10-11-12	1	10
472841EX	10-11-12	1	10-11
472842EX	10-11-12	1	10
476903EX	10	1	7
476905EX	10	1	7
476907EX	10	1	7
476909EX	10	1	7
476913EX	10	1	7
476923EX	10	1	7
476925EX	10	1	7
5EX			
511910EX	10-11-12	1	21
511911EX	10-11-12	1	21
511912EX	10-11-12	1	21
511913EX	10-11-12	1	21
511914EX	10-11-12	1	17
511917EX	10-11-12	1	21
511919EX	10-11-12	1	17
511920EX	10-11-12	1	21
511921EX	10-11-12	1	21
511922EX	10-11-12	1	21
511923EX	10-11-12	1	21
532005EX	10-11-12	1	19
532006EX	10-11-12	1	19
532015EX	10-11-12	1	19
532016EX	10-11-12	1	19
532017EX	10-11-12	1	19
532018EX	10-11-12	1	19
532018EX	10-11-12	1	19
532035EX	10-11-12	1	19

Palazzoli code	Marks	Pack Q.ty	Catalogue page
532045EX	10-11-12	1	19
532055EX	10-11-12	1	19
532116EX	10-11-12	1	19
532117EX	10-11-12	1	19
532118EX	10-11-12	1	19
532200EX	10-11-12	1	19
532201EX	10-11-12	1	19
532202EX	10-11-12	1	19
532203EX	10-11-12	1	19
532204EX	10-11-12	1	19
532240EX	10	1	12
532242EX	10	1	12
532244EX	10	1	12
538421EX	10	1	12
538429EX	10	1	12
538436EX	10	1	12
540061EX	10-11-12	1	21
540063EX	10-11-12	1	21
540065EX	10-11-12	1	21
540180EX	10-11-12	1	17-21
540185EX	10-11-12	1	17
540186EX	10-11-12	1	17
540190EX	10-11-12	1	21
540195EX	10-11-12	1	21
541050EX	10-11-12	1	21
541055EX	10-11-12	1	17-21
571009EX	10-11-12	50	25
571011EX	10-11-12	50	25
571013EX	10-11-12	50	25
571016EX	10-11-12	50	25
571021EX	10-11-12	20	25
571029EX	10-11-12	20	25
571036EX	10-11-12	10	25
571042EX	10-11-12	5	25
571048EX	10-11-12	5	25
571109EX	10-11-12	50	25
571111EX	10-11-12	50	25
571113EX	10-11-12	50	25
571116EX	10-11-12	50	25
571121EX	10-11-12	20	25
571129EX	10-11-12	20	25
571136EX	10-11-12	10	25

Palazzoli code	Marks	Pack Q.ty	Catalogue page
571142EX	10-11-12	5	25
571148EX	10-11-12	5	25
580360EX	10-11-12	1	27
580361EX	10-11-12	1	27
580364EX	10-11-12	1	27
580365EX	10-11-12	1	27
580394EX	10-11-12	1	27
580395EX	10-11-12	1	27
580396EX	10-11-12	1	27
580416EX	10-11-12	1	27
580420EX	10-11-12	1	27
580425EX	10-11-12	1	27
580432EX	10-11-12	1	27
580440EX	10-11-12	1	27
580450EX	10-11-12	1	27
580463EX	10-11-12	1	27
581012EX	10-11-12	50	26
581016EX	10-11-12	50	26
581020EX	10-11-12	50	26
581025EX	10-11-12	20	26
581032EX	10-11-12	20	26
581040EX	10-11-12	20	26
581050EX	10-11-12	10	26
581063EX	10-11-12	5	26
581112EX	10-11-12	50	26
581116EX	10-11-12	50	26
581120EX	10-11-12	50	26
581125EX	10-11-12	20	26
581132EX	10-11-12	20	26
581140EX	10-11-12	20	26
581150EX	10-11-12	10	26
581163EX	10-11-12	5	26
582112EX	10-11-12	50	27
582116EX	10-11-12	50	27
582120EX	10-11-12	50	27
582125EX	10-11-12	20	27
582132EX	10-11-12	20	27
582140EX	10-11-12	20	27
582150EX	10-11-12	10	27
582163EX	10-11-12	5	27
7EX			
760124EX	10-11-13	1	7

Mark legend: 10 =  ATEX 11 =  IECEX 12 =  INMETRO

SEQUENTIAL INDEX

Palazzoli code	Marks	Pack Q.ty	Catalogue page
760126EX	10-11-13	1	7
760129EX	10-11-13	1	7
760134EX	10-11-13	1	7
760136EX	10-11-13	1	7
760137EX	10-11-13	1	7
760139EX	10-11-13	1	7
760144EX	10-11-13	1	7
760146EX	10-11-13	1	7
760147EX	10-11-13	1	7
760149EX	10-11-13	1	7
760224EX	10-11-13	1	7
760226EX	10-11-13	1	7
760229EX	10-11-13	1	7
760234EX	10-11-13	1	7
760236EX	10-11-13	1	7
760237EX	10-11-13	1	7
760239EX	10-11-13	1	7
760244EX	10-11-13	1	7
760246EX	10-11-13	1	7
760247EX	10-11-13	1	7
760249EX	10-11-13	1	7
760324EX	10-11-13	1	7
760326EX	10-11-13	1	7
760329EX	10-11-13	1	7
760334EX	10-11-13	1	7
760336EX	10-11-13	1	7
760337EX	10-11-13	1	7
760339EX	10-11-13	1	7
760344EX	10-11-13	1	7
760346EX	10-11-13	1	7
760347EX	10-11-13	1	7
760349EX	10-11-13	1	7
8EX			
810020EX	10	1	47
810021EX	10	1	47
810022EX	10	1	47
810050EX	10	1	47
810051EX	10	1	47
810052EX	10	1	47
810080EX	10	1	47
810081EX	10	1	47
810082EX	10	1	47

Palazzoli code	Marks	Pack Q.ty	Catalogue page
810090EX	10	1	47
810091EX	10	1	47
810092EX	10	1	47
810226EX	10	1	47
810256EX	10	1	47
810286EX	10	1	47
810296EX	10	1	47
820111EX	10	1	41
820131EX	10-11 12-13	1	41
820132EX	10-11 12-13	1	41
820211EX	10	1	41
820231EX	10-11 12-13	1	41
820232EX	10-11 12-13	1	41
820311EX	10	1	41
820331EX	10-11 12-13	1	41
820332EX	10-11 12-13	1	41
822111EX	10	1	41
822131EX	10-11 12-13	1	41
822132EX	10-11 12-13	1	41
822140EX	10	1	45
822142EX	10	1	45
822181EX	10-11 12-13	1	39
822182EX	10-11 12-13	1	39
822211EX	10	1	41
822231EX	10-11 12-13	1	41
822232EX	10-11 12-13	1	41
822240EX	10	1	45
822242EX	10	1	45
822281EX	10-11 12-13	1	39
822282EX	10-11 12-13	1	39
822311EX	10	1	41
822331EX	10-11 12-13	1	41
822332EX	10-11 12-13	1	41
822340EX	10	1	45
822342EX	10	1	45
830072EX	10-11-13	1	43
831072EX	10-11-13	1	43
831172EX	10-11-13	1	43
831272EX	10-11-13	1	43
842140EX	10	1	45
842142EX	10	1	45
842240EX	10	1	45

Palazzoli code	Marks	Pack Q.ty	Catalogue page
842242EX	10	1	45
9EX			
900253EX	10-11-13	1	37
900263EX	10-11-13	1	37
900273EX	10-11-13	1	37
900453EX	10-11-13	1	37
900463EX	10-11-13	1	37
900473EX	10-11-13	1	37
4			
478126		1	12-17
478136		1	12-17
478146		1	12-17
478206		1	12-17
478246		1	12-17
478306		1	12-17
5			
532700		1	19
532701		1	19
532702		1	19
532703		1	19
532704		1	19
532705		1	19
532714		1	19
532715		1	19
532716		1	19
532717		1	19
532718		1	19
532836		1	17
532876		1	17
538410		1	12-19
538800		1	12
538802		1	12
538804		1	12
571209		50	25
571211		50	25
571213		50	25
571216		50	25
571221		25	25
571229		20	25
571236		10	25
571242		5	25
571248		5	25

Palazzoli code	Marks	Pack Q.ty	Catalogue page
581212		50	26
581216		50	26
581220		50	26
581225		50	26
581232		50	26
581240		20	26
581250		10	26
581263		5	26
582212		50	27
582216		50	27
582220		50	27
582225		25	27
582232		20	27
582240		10	27
582250		10	27
582263		5	27
8			
810994		1	47
810996		1	47
810997		1	47
810998		1	47
820000		1	41-45
820001		1	41-45
820002		1	39
820003		1	39
820006		1	41-45
820010		1	39
820011		1	39
820016		1	39
820017		1	39
9			
900449		1	37

Mark legend: : 10 =  ATEX 11 =  IECEx 12 =  INMETRO

GENERAL SALE AND SUPPLY TERMS

PALAZZOLI S.P.A.
ELECTROTECHNIC INDUSTRY
25128 BRESCIA - ITALY - Via F. Palazzoli, 31
tel. +39 030.2015.1 fax +39 030.2015.258
http://www.palazzoli.com
e-mail: export@palazzoli.com

Palazzoli

Fully p.u. capital 5.096.000 Euro i.v.
Fiscal code 04452750484
VAT code 03316260177
Brescia Chamber of C. N. 356562
Reg. Brescia Court N. 04452750484
Data code BS 058237

(Registered in Brescia 6 March 1956, N. 9907, Mod. 2, Vol. 359, Private Acts) OFFERS - ESTIMATES - DESIGNS

- 2 - The terms and other commitments taken on by us with the offer are only valid if the order extends to everything that is included in the offer.
- 3 - Estimates, general projects, etc. attached to the offer are our exclusive property and thus may not be disclosed to others without our written approval.
- 4 - Any alteration to the offer and to these general supply terms must be in writing and limited to what has been explicitly agreed.

WEIGHTS - DIMENSIONS - TECHNICAL DATA

- 5 - Estimates, plans, drawings and technical data given in the catalogues, price lists and offers are only approximate until such time as they are confirmed or replaced by definitive data, total or partial, at the moment of ordering.

PRICES

- 6 - The prices and discounts in the price lists and offers may be subject to change depending on the requirements of the market or relating to variations in the costs of raw materials or manpower, without prior notice to customers. The prices given are ex-factory; transport, customs, duties, and rights of any nature are always to the customer's charge, unless otherwise agreed in writing.

PACKING AND TRANSPORT

- 7 - Returns are not accepted on packing. Under no circumstance, our company can be held liable for failed or irregular deliveries by carriers, and it is to be expressly understood that goods, even where, by special agreement, they are sold with free delivery or delivered to the customer's domicile, will always travel at the buyer's full risk. Any return of goods must be authorised beforehand by our company and arrive free of all expense in the warehouse of our factory.

DELIVERY TERMS

- 8 - The delivery terms agreed on are approximate and not binding and, under the clause "providing unsold" for goods signalled as being ready, it is intended to be valid only in normal work and supply conditions. In no circumstance and for no reason will our company be held liable to make a reimbursement for any direct or indirect damage due to delays in delivery.

PAYMENT

- 9 - The payment conditions must be agreed in writing or, otherwise, they are understood to be for the net amount in cash at the moment of delivery of the goods. In the case of delayed payment, the customer undertakes to pay interest at an average market rate applied by the Bank, increased by 4%. If the buyer does not comply with, even only partly, any of the agreed conditions for collecting the goods or for the regular payment of single invoices, our company has the option of immediately interrupting further deliveries and to consider itself released from any contractual commitment, but maintaining all rights regarding the buyer's failure to comply with the contract. Unless otherwise expressly agreed, payments must always be made directly to our company.

CLAIMS

- 10 - Any claims regarding goods supplied must reach us within 12 days of delivery of the same, after which time they will not be accepted. Any claim must be based on firm data in order to be taken into consideration.

We reserve the option of taking back or replacing goods that the customer demonstrates to us to be defective, but we will not acknowledge any payment made for repairs or exchange which have been done without our authorisation. It is to remain understood that any claims put forward on single parts of the order will not affect the rest of the order or undertaking, nor the payment for goods received without objection.

WARRANTIES

- 11 - The warranties that we adopt for material manufactured by us will last 12 months from the date of the invoice concerned. It is understood that, during this period, we undertake to repair or replace free of charge in our workshop those parts or devices which, by defect in manufacture or materials, are seen to be unusable. Nonetheless, we reserve the right to decide in our sole opinion, if it is better to repair or to replace them. We shall not send our staff on site for inspection purposes of places where our equipment has been used in systems, apart from those cases where it is necessary to check the operating conditions to which our equipment has been subject.
- 12 - Our warranty has natural effect only if the apparatus has been perfectly installed and managed, they have not been tampered with or modified, and all the technical regulations contained in our catalogues and instruction sheets have been followed. The warranty does not cover those items which, by the nature of the material of which the items are made or due to their specific use, are subject to early wear, and in the same way, breakdowns due to normal wear and tear are excluded.
- 13 - The customer must give written notice of faults and defects detected, with a precise report on their nature. We undertake to repair or replace the item, within a reasonable period, as per the above mentioned circumstances and terms. Material to repair or replace must be returned to us free of charge.
- 14 - Our company, with the repair or replacement of items or parts which were defective, is to be considered released of all further liability. Moreover, the customer must, by way of this, consider himself satisfied and waive any request for damages and expenses. In particular cases we may permit the customer to provide for repair or replacement himself, with our only obligation being to reimburse the out-of-pocket expenses acknowledged as being essential for putting our equipment into working condition.
- 15 - If there should be a dispute of a technical nature, the parties will obtain the opinion of an inspector to be nominated by agreement or, if there is a dispute over the nomination, then the person will be appointed by the presiding judge of Brescia Court.
- 16 - We will not accept any costs that the buyer has incurred, not even during the warranty period, without our prior written agreement.
- 17 - Our company reserves the right to use, in the manufacture of its equipment, any material that it deems suitable and to make any changes in shape, weight or dimensions in its products that it feels appropriate.

DISPUTES

- 18 - The contracts, even if stipulated with foreign companies or persons or for material supplied abroad, are governed by current Italian law. The competent court will only be that of Brescia notwithstanding articles 31 (et seq.) of the Italian Civil Procedure Code, thereby excluding the customer possibility of having recourse to Judicial Authorities of any other place, even for investigations or in any connection with the case, but permitting the supplying company the option of taking legal proceedings, as a plaintiff, in the customer place of residence, in Italy or abroad.
- 19 - Any disputes do not release the customer from complying with the payment terms and do not imply any extension to the times agreed.

Palazzoli reserves the right to modify or improve the product at any time without prior notice.

All rights reserved in all countries, in particular the right to translate, to store electronically, to reproduce or to adapt totally or partially.
No liability will be assumed for any damages that may arise from the use of this data.

Catalogue Book
ATEX 2019

Solutions for explosive atmospheres

palazzoli.com

Palazzoli S.p.A. Via F. Palazzoli, 31 - 25128 Brescia - Italy
Tel. +39 030 2015.1 - Fax +39 030 2015.258
export@palazzoli.com

Palazzoli